



# DESIGN AND CONSTRUCTION STANDARDS



## **DESIGN AND CONSTRUCTION STANDARDS**

|                  |  |
|------------------|--|
| <b>SECTION 1</b> | <b>GENERAL DESIGN AND APPLICATION SUBMITTAL REQUIREMENTS</b> |
| <b>SECTION 2</b> | <b>STORMWATER DESIGN AND CONSTRUCTION</b>                    |
| <b>SECTION 3</b> | <b>WASTEWATER DESIGN AND CONSTRUCTION</b>                    |
| <b>SECTION 4</b> | <b>WATER DESIGN AND CONSTRUCTION</b>                         |
| <b>SECTION 5</b> | <b>STANDARD DRAWINGS</b>                                     |



## DESIGN AND CONSTRUCTION STANDARDS

This document is intended to be updated annually. If errors are found, please cite them and submit them to Oak Lodge Water Services Engineering Department:

Phone: (503) 654-7765

Email: [Permits@OLWS.org](mailto:Permits@OLWS.org)

### Versions

OLWS October 10, 2024: Adopted by Resolution Number 2024-031 September 10, 2024

OLWSD February 18, 2021: Adopted by Resolution Number 2021- 01 January 19, 2021

OLWSD April 17, 2020: Adopted by Resolution Number 2020-02 March 17, 2020

OLWSD February 15, 2019: Adopted by Resolution Number 19- 01 February 15, 2019

OLWSD October 17, 2017: Adopted by Resolution Number 17- 14 October 20, 2017 (Oak Lodge Water Services District)

OLSD March 2, 2016: Adopted by Ordinance 85; March 8, 2016 (Oak Lodge Sanitary District)

# SECTION 1—GENERAL DESIGN AND APPLICATION SUBMITTAL REQUIREMENTS

## TABLE OF CONTENTS

- 1.0 GENERAL..... 1
  - 1.0.1 Authority and Purpose and Alternative Design Proposals..... 1
  - 1.0.2 Engineering Policy ..... 1
  - 1.0.3 Applicability and Permit Types..... 2
  - 1.0.4 Conflicting Codes, Regulations, Rules, Standards ..... 4
  - 1.0.5 Standard Specifications..... 4
  - 1.0.6 Approval of Alternate Materials Or Methods ..... 4
  - 1.0.7 Special Design Problems ..... 4
  - 1.0.8 Revisions to Design and Construction Standards ..... 5
  - 1.0.9 Definitions and Abbreviations..... 5
- 1.1 CONSTRUCTION PLANS ..... 29
  - 1.1.1 General Information..... 29
  - 1.1.2 Plan Preparation..... 29
  - 1.1.3 Required Sheets ..... 30
  - 1.1.4 Supporting Information ..... 33
  - 1.1.5 Plan Submittal and Review Procedures ..... 40
  - 1.1.6 As-Built Plan Requirements ..... 41
  - 1.1.7 Plan Quality and Miscellaneous Requirements ..... 42
  - 1.1.8 Permit and Approval Vesting and Amendments ..... 43
  - 1.1.9 Disconnections ..... 44
  - 1.1.10 Replacement Service Lateral Installations ..... 44
  - 1.1.11 Building Sewer Repair ..... 44
  - 1.1.12 Connection to Cesspools And Septic Tanks ..... 44
  - 1.1.13 Sanitary Sewer Backflow ..... 44
  - 1.1.14 Ownership and Acceptance And Bonding..... 45
  - 1.1.15 Inspections and Authority..... 45
  - 1.1.16 Construction Quality ..... 47
  - 1.1.17 Construction Duration..... 47
  - 1.1.18 Damage ..... 48



1.1.19 DEQ Authority and Process ..... 48

1.1.20 Agency Coordination..... 48

1.2 GENERAL CONSTRUCTION REQUIREMENTS ..... 48

1.2.1 Instructions to Bidders..... 48

1.2.2 Award and Execution of Contract ..... 49

1.2.3 Scope of Work ..... 49

1.2.4 Control of Work..... 51

1.2.5 Control of Materials ..... 58

1.2.6 Legal Relations and Responsibilities ..... 60

1.2.7 Prosecution and Progress of Work ..... 69

## **1.0 GENERAL**

---

### **1.0.1 Authority and Purpose and Alternative Design Proposals**

OLWS Design and Construction Standards establish and provide specific, technical direction for the design and construction of public sanitary sewer, public water and public and private watershed protection projects. Through the adoption of these standards, OLWS endorses a comprehensive set of design and construction practices that are designed to deliver high quality improvements to OLWS customers.

Infrastructure improvements are conditioned through development permits including the Clackamas County development review, and/or building permit, and/or plumbing permit, and/or OLWS-specific permit process, these standards, and other OLWS policies adopted by OLWS. No relevant utility or infrastructure construction shall commence prior to OLWS approval of the construction plans. OLWS may require documents to be stamped by a Registered Professional Engineer licensed to practice by the State of Oregon.

The purpose of these Design and Construction Standards is to provide a consistent policy under which certain physical aspects of public facility design are constructed. Most of the elements contained in these standards are Infrastructure-oriented and it is intended that they apply to both public improvements under OLWS contract and public improvements under private contract designated herein.

These Design and Construction Standards cannot provide for all situations. They are intended to assist but not to substitute for competent work by design professionals. It is expected that engineers will bring to each project the best of skills from their respective disciplines.

The Design and Construction Standards are also not intended to unreasonably limit any innovative or creative effort, which could result in better quality, better cost savings, and/or better life cycles. Any proposed departure from the Design and Construction Standards will be judged, however, on the likelihood that such departure will produce a compensating or comparable result in every way adequate for the user and OLWS's customer. Alternate materials, methods or design will be considered for approval by the District Engineer as the need arises and conditions warrant modification. This consideration will be on a case-by-case basis and require sufficient justification prior to approval. The justification shall be submitted in writing and shall state the standard being changed and the rationale. If the proposed alternative cannot be agreed to, the owner shall submit a variance as described in the Section 2 of the Design Standards.

The purpose of this Chapter is to describe the permit types, common scenarios activating those permits, common permit review procedures and responsibilities. These are provided as examples and any application may vary depending on relative conditions.

### **1.0.2 Engineering Policy**

It shall be the policy of OLWS to require compliance with all state and federal standards for professional engineers.

All engineering plans, reports, or documents shall be prepared by a registered professional engineer, or by a subordinate employee under the engineer's direction, and shall be signed by the engineer and stamped with the engineer's seal to indicate the engineer's responsibility for them. This engineer is designated by these Standards to be the Design Engineer. Through the permit review process, it shall be the Design Engineer's responsibility to review any proposed public facility extension, modification, or other change with OLWS prior to engineering or proposed design work to determine any special requirements (conditions) or whether the proposal is permissible.

A "Not Approved For Construction" and/or a "Plans Approved for Construction" stamp of OLWS on the plans, etc., for any job, does not in any way relieve the Design Engineer of responsibility to meet all requirements of OLWS or obligation to protect life, health, and property of the public. The plan for any project shall be revised or supplemented at any time it is determined that the full requirements of OLWS have not been met.

### **1.0.3 Applicability and Permit Types**

These Design and Construction Standards shall govern all construction and upgrading of all public and privately financed public facilities in OLWS and applicable work within its service areas.

An OLWS-issued permit is required prior to any work commencing. Failure to acquire permit(s) equates to a violation of the Rules and Regulations. The issuance of a permit by OLWS will not relieve the permit holder from the responsibility of obtaining such other permits or licenses as may be required by other governmental agencies.

#### **1.0.3.01 Permit Types**

**Site Development Permits** are required for line extensions, subdivisions/partitions and / or site development or redevelopment (partial or wholesale) including middle-housing land divisions. A line extension includes any proposal to install, lengthen, enlarge, amend, repair, replace, upgrade or alter any existing sanitary sewer or water main line or other portion of the public system other than a side sewer lateral or water service. Line extensions also include vertical alignment changes. Any alteration to a public main line is considered a "line extension" The County equivalent permit numbers are typically "Z....xxx" and/or "SC.....xxx" and include subdivisions, partitions, design review, site clearing and similar applications. Site Development permits are to be garnered for any relevant activity within OLWS Boundary and / or Service Area. Line Extension Permits are processed as a "Site Development" permit.

**Utility Permits** are required to install new, or lengthen, enlarge, amend, repair, replace, upgrade or alter any existing sanitary sewer lateral or water service or other portion of the public system other than a main line or other portion of the public system not a line extension. The County equivalent permits can be "Z....xxx" and/or "SC.....xxx", but typically are associated with a "B.....xxx" and include, tenant improvements, building permits and occupancy permits and similar applications. Examples include single family residences, ADUs, sewer taps, water service installations, meter size changes, lateral or

service repair in the public right of way. Utility Connection Permits are to be garnered for any relevant activity within OLWS Boundary and / or Service Area.

**Disconnection:** A utility permit is garnered for any service discontinuance or abandonment. A disconnection requires a utility permit when any property(ies), existing service(s) either physical or virtual to be disconnected from the sanitary sewer or water system. Disconnection permits shall be required when a structure(s) is demolished wholly or may be required at OLWS discretion if the structure(s) is partially demolished.

**Virtual Connection:** Utility service connection permits are required for virtual connections to evaluate the effluent volume and strength (see definition “virtual connection”). Virtual connections do not typically install, lengthen, enlarge, amend, repair, replace, upgrade or alter any existing sanitary sewer or water main line or other portion of the public system and may not have any sanitary sewer work outside the building envelope at all. The County equivalent permits are “Z....xxx and / or B...xxxx” and include design review, tenant improvements, building and occupancy permits, process changes and similar applications. Examples include tenant improvement occupancy changes, production process intensification or reduction, or increased wastewater strength or volume. Utility Connection Permits are to be garnered for any relevant activity within OLWS Boundary and / or Service Area. Virtual Connection Permits are processed as a “Utility Permit”.

**Erosion Control/Surface Water Management Permit:** OLWS issues Erosion Control/Surface water Management Permits within its jurisdictional area. All construction activities affecting areas 500 square feet up to five (5) acres within OLWS shall obtain an Erosion Control/Surface Water Management Permit. Construction activities affecting areas 250 square feet or greater within the undisturbed buffer, sensitive areas, or riparian areas must also obtain an Erosion Control/ Surface Water Management Permit. An Erosion Control/Surface Water Management Permit is also required to discharge to the stormwater system.

**NPDES 1200-CN and 1200-C Permit**

In addition to OLWS EPSC Permit, a NPDES 1200-CN permit is required for projects disturbing one acre up to less than 5 acres of disturbance. The 1200-CN shall be issued by OLWS along with the local permit.

For disturbances of 5 acres or greater, an OLWS EPSC Permit and a DEQ 1200-C permit is required. The local permit may also be issued by OLWS. The 1200-C permit shall be obtained directly from DEQ. In the case of a residential subdivision, the “child lots” created with the subdivision may be required by OLWS to obtain individual ECSL permits.

**Clackamas County Utility Placement Permit**

Utility Placement Permits (Road Opening) may be required by Clackamas County if work enters the public right-of-way or other applicable area.

#### **1.0.4 Conflicting Codes, Regulations, Rules, Standards**

Where these Design and Construction Standards conflict with other applicable codes, Regulation or Rule or Standard, the more restrictive code shall prevail.

#### **1.0.5 Standard Specifications**

All construction design detail, workmanship, and materials shall be in accordance with the current edition of OLWS Standards.

OLWS's Standard Drawings shall be used for public and private development projects and cannot be modified by designers, unless approved by OLWS on a project-by-project basis. It is the responsibility of the Engineer to incorporate the standard detail drawings as originally intended.

#### **1.0.6 Approval of Alternate Materials Or Methods**

Any substitution, material or alternate method not explicitly approved herein will be considered for approval as set forth in Subsection 1.0010 (Authority and Design Standards 2.2.4 Variance). Persons seeking such approvals shall make an application in writing. Approval of any major deviation from these Design and Construction Standards will be in written form. Approval of minor matters will be made in writing if requested.

Any alternative must meet or exceed the minimum requirements set in these Design and Construction Standards.

The request must meet the requirements of Rules and Regulations Section Design Standard Section 2.2.4 Variance, and the written application shall include, but is not limited to, the manufacturer's specifications and testing results, design drawings, calculations, and other pertinent information.

Any deviations or special problems shall be reviewed on a case-by-case basis and approved by the District Engineer. When requested by OLWS, full design calculations shall be submitted for review with the request for approval.

#### **1.0.7 Special Design Problems**

Special applications not covered in these Design and Construction Standards require review and approval by the District Engineer. Submittal of full design calculations, supplemental drawings, and information will be required prior to any approval.

Such applications which may require special review and approval are among, but not limited to, the following.

|                                     |                                   |
|-------------------------------------|-----------------------------------|
| Sewer Force Mains                   | Water Distribution Pump Stations  |
| Relining of Existing Sewers         | Relining of Existing Water Mains  |
| Internal Sealing of Existing Sewers | Water Pressure Regulating Devices |
| Sewer Regulatory Devices            | Energy Dissipaters                |
| Sewage Pump Stations                | Water Reservoirs                  |
| Sewer Siphons                       | Water Treatment Plants            |

### **1.0.8 Revisions to Design and Construction Standards**

It is anticipated that revisions to these Design and Construction Standards will be made from time to time. The date appearing on the title page is the date of the latest revision. Users should apply the latest published issue to the work contemplated.

Parenthetical notations at the end of sections indicate the most recent change to those sections. All sections without notations are from the original Design and Construction Standards as adopted. Some sections may be changed more than once and it shall be the user's responsibility to maintain their copy of these Design and Construction Standards with the latest changes.

### **1.0.9 Definitions and Abbreviations**

#### **1.0.9.01 Definitions**

##### **Acceptance of work**

All work required by the contract documents and/or conditions of approval will be considered accepted upon approval of the Certificate of Completion by OLWS.

##### **Advertisement**

The public announcement inviting bids for work to be performed or materials to be furnished.

##### **Applicant**

See the OLWS Rules.

##### **Approved Point of Discharge.**

A location down slope from a development that OLWS has deemed adequate to accept stormwater flows from all or a portion of the Development area.

##### **Approved backflow prevention device**

A backflow prevention device that has been investigated and approved by the Oregon State Health Division.

##### **As-built plans**

Plans signed and dated by the Design Engineer indicating that the plans have been reviewed and revised, if necessary, to accurately show all as-built construction details.

##### **Attorney**

The OLWS Legal Counsel.

##### **Back Siphonage**

Backflow that results from negative pressure (partial vacuum) in the supply piping system.

**Backflow**

The reverse of flow from its normal or intended direction of flow. Backflow can be caused by back pressure or back siphonage.

**Backflow preventer**

An approved device or means to prevent backflow into the potable water system.

**Best Management Practices (BMP)**

Requirements, methods, measures, practices, or design and performance standards imposed on an owner or operator that facilitate compliance with this Code, applicable water quality standards or with requirements for dredged fill materials. BMPs may cover treatment requirements, operating and maintenance procedures, schedules of activities, prohibitions of activities, and other management practices to control plant site run-off, spillage, leaks, sludge or water disposal, or drainage from raw material storage.

**BMP Sizing Tool.**

A computer program, approved by OLWS, for use in calculating the required size of Stormwater Management Facilities (SMFs). This tool is limited to a set list of pre-defined SMFs. See Clackamas County Water Environment Services BMP Sizing Tool webpage:

<https://www.clackamas.us/wes/bmp-sizing-tool>

**Board**

The Board of Directors of Oak Lodge Water Services Authority.

**Bioswale**

Landscaped elements designed to remove silt and pollution from surface runoff water. They consist of a drainage course with gently sloped sides (less than six percent) and filled with vegetation.

**Bond**

See the OLWS Rules.

**Buffer**

Generally, the zone contiguous with a sensitive area that is required for water quality. The critical functions of a riparian buffer (those associated with an aquatic system) include shading, input of organic debris and coarse sediments, uptake of nutrients, stabilization of banks, interception of fine sediments, overflow during high water events, protection from disturbance by humans and domestic animals, maintenance of wildlife habitat, and room for variation of aquatic system boundaries over time due to hydrologic or climatic effects. The relevant regulatory agency's definition shall supersede this definition.

**Building Drain**

See the Oregon State Specialty Code (Plumbing)

**Building service lateral / sewer lateral**

See Rules and Regulations definitions “sewer lateral”

**Building sewer**

See Rules and Regulations definitions “building sewer”.

**Building supply**

See Rules and Regulations definitions “service line”.

**Business Customer**

A person who resides or conducts business or other activities on a parcel zoned for business. Mere ownership and activities that are necessary to prevent or abate nuisance conditions or to avoid deterioration of a business parcel shall not constitute “residing” or “conducting business or other activities”.

**Business Parcel**

A parcel of land, which is zoned for business use.

**CBE**

Crushed based equivalent (CBE) is the number that directly relates the traffic coefficient to the number of inches of rock.

**Certificate of Completion**

Standard OLWS form, which must be signed by the Contractor.

**Certificate of Compliance**

Standard OLWS form, which must be signed by the Contractor, stating compliance with the contract documents and/or conditions of approval.

**Change Order**

A written order issued by the District Engineer to the Contractor directing changes in the work, subject to approval of OLWS.

**Collection systems**

Facilities maintained by OLWS for the purposes of collecting, pumping, conveying, and controlling of wastewater.

**Conservation Easements**

A voluntary agreement that allows a property owner to permanently limit the type and amount of development on their property while retaining private ownership.

**Construction Activity**

Ground disturbance activities including, but not limited to, clearing, grading, excavation, or filling, or activities subject to a building permit.

**Contract**

The document entitled "contract" or "agreement" which is executed by the Contractor and the OLWS; authorizing ordinance; advertisement calling for bids; bid; instructions to bidder; plans; and all specifications, addenda, permits, performance bond, insurance



certificates, and change order for any approved revisions made during the performance of the work to any of the above listed documents, collectively referenced as the "contract documents."

**Contract Cost**

The aggregate amount of price promised to be paid by OLWS to Contractor upon fulfillment of the Contract.

**Contract Item**

A specific unit of work for which a price or basis of payment is provided in the Contract.

**Contractor**

A person duly licensed or approved by the State of Oregon to perform the type of work to be done under a permit or contract issued by OLWS.

**Conveyance System.**

See the OLWS Rules. As relates to these Standards, conveyance system refers to the stormwater and surface water conveyance system and includes sewers SMFs, drainageways, detention facilities, infiltration facilities, pretreatment facilities.

**Core**

To cut and remove a portion of pipe with a circular hollow drill.

**County**

Clackamas County, Oregon.

**Cross-connection**

Any actual or potential physical connection between a potable waterline and any pipe or vessel containing a nonpotable or potable (e.g., well) fluid (suspended solid or gas) so that it is possible to introduce the nonpotable fluid into the potable fluid by backflow.

**Curb**

The concrete structure indicating the edge of the vehicular roadway within the overall right-of-way.

**Customer**

See OLWS Rules.

**Customer Charge**

The periodic charges applied to all customers of OLWS Surface Water Management system for the cost of planning, program development, public education, operation, maintenance, and replacement; including any other costs, such as but not limited to, debt service, capital improvements, administration, etc. This does not include charges from specific fees related to permits or one-time service fees.

**Cut sheets**

Sheets of tabulated data, indicating stationings, structures, fittings, angle points, beginning of curve, points on curve, end of curves, stormwater drain slope, staking

offset, various elevations, offset cuts, and stormwater drain depths for streets, waterlines, sanitary sewers, and stormwater drains.

**Datum**

The vertical elevation control.

**Day**

Calendar day; i.e., any and every day shown on the calendar, Sundays and holidays included.

**Debris**

Discarded human made objects that would not exist in an undeveloped stream corridor or wetland. Debris includes, but is not limited to, tires, vehicles, litter, scrap metal, construction waste, lumber, plastic, or Styrofoam. Debris does not include objects necessary to a use allowed by Section 709, or ornamental and recreational structures. Debris does not include existing natural plant materials or natural plant materials that are left after flooding, downed, or standing dead trees, or trees that have fallen into protected water resources.

**Dedication**

The legal conveyance of land, typically from a private property owner to OLWS.

**Definition of words**

That, whenever, in these Standards, the words "directed", "required", "permitted", "ordered", "designated," or words of like importance are used, they shall be understood to mean the direction, requirement, permission, or order of designation of the District Engineer. Similarly, the words "approved", "acceptable", or "satisfactory", shall mean approved by, acceptable to, or satisfactory to the District Engineer.

**Design Engineer**

The engineer, licensed by the State of Oregon as a Professional Engineer under whose direction plans, profiles, and details for the work are prepared and submitted to OLWS for review and approval, or who is in charge of and responsible for construction of the improvement.

**Design Storm**

The distribution of rainfall intensity over time, identified to have a probability of recurrence, given in years (i.e., 5-year design storm).

**Detention**

The holding of runoff for a designed period of time and then releasing it to the natural water course.

**Developer**

See the OLWS Rules.

**Developer’s Engineer**

See the OLWS Rules.

**Developer’s Engineer’s Inspector, or Engineer’s Inspector**

The Developer’s Engineer’s Inspector(s) shall be the Developer’s Engineer of record, or recognized as representatives of the Developer’s Engineer, and their duties shall be to approve materials and workmanship as required by the plans and specifications in accordance with OLWS Stormwater Standards.

**Development**

All human-induced changes to improved or unimproved real property. .

**Discharge**

Any addition of water, stormwater, wastewater, process water or any pollutant or combination of pollutants to waters of the State, directly or indirectly, by actions of dumping, spilling, disposing or physically connecting to the public stormwater system or natural drainage conveyance.

**District**

Oak Lodge Water Services Authority.

**District Employee or District Personnel.**

See OLWS Rules.

**District Engineer**

The District Engineer, or General Manager, of OLWS, acting either directly or through authorized representatives.

**Disturbed Area or Disturbance**

Areas of disturbance for activities defined under “Development”. Work area includes areas used for storage of equipment or materials that are used for these activities.

**Domestic sewage**

The liquid and water-borne waste derived from ordinary living processes, free from industrial wastes, and of such character to permit satisfactory disposal without special treatment into the public sewer or by means of a private sewage disposal system.

**Double check detector check valve assembly**

A line-sized, approved, double check valve assembly with a parallel meter and meter-sized, approved, double check valve assembly. The purpose of this assembly is to provide backflow protection for the distribution system and, at the same time, provide a metering of the fire system showing any system leakage or unauthorized use of water.

**Double check valve assembly**

An assembly composed of two single, independently acting, approved check valves, including tightly closing shutoff valves located at each end of the assembly and fitted with properly located test cocks.

**Drainage facilities**

Pipes, ditches, detention basins, creeks, culvert bridges, etc., used singularly or in combination with each other for the purpose of conveying or storing stormwater runoff.

**Drainageway**

A channel such as an open ditch that carries stormwater.

**Dwelling Unit**

As defined by Clackamas County.

**Drywell**

An approved receptacle used to receive storm, surface and other water, the sides and bottom being porous, permitting the contents to seep into the ground. A drywell must conform to local agency standards and Oregon Department of Environmental Quality (DEQ) Underground Injection Control (UIC) standards.

**Easement**

Areas located outside of dedicated rights-of-way, which are granted to OLWS for special uses.

**(Private) Easement**

An area on a parcel that benefits other parcel(s) by granting special uses.

**Emergency**

Any anthropogenic or natural event or circumstance causing or threatening loss of life, injury to person or property, and includes, but is not limited to, fire, explosion, flood, severe weather, drought, earthquake, volcanic activity, spills or releases of oil or hazardous material, contamination, utility or transportation disruptions, and disease.

**Engineer or Professional Engineer (PE)**

A registered professional engineer licensed to practice in the State of Oregon by the Oregon Board of Engineering Examiners. This person is also referred to as the project engineer or the engineer of record.

**Enhancement**

The process of improving upon the natural functions and/or values of an area or resource that has been degraded by human activity. Enhancement activities may or may not return the site to a pre-disturbance condition but create/recreate beneficial processes and resources that occur naturally.

**Equivalent Service Unit (ESU)**

A configuration of development resulting in impervious surfaces on a parcel, which contributes runoff to the stormwater system. One ESU is equal to 2,500 square feet of impervious surface area.

**Erosion**

Erosion is the movement of soil particles resulting from the flow or pressure from water, wind, or earth movement. Visible or measurable, construction-related erosion includes, but is not limited to:

- Deposits of mud, dirt, sediment or similar material exceeding ½-cubic-foot in volume on public or private streets, adjacent property, or into the stormwater

system, either by direct deposit, dropping, discharge, or as a result of the action of erosion during the construction period.

- Evidence of concentrated flows of water over bare soils; turbid or sediment-laden flows; or evidence of onsite erosion such as rivulets or bare soil slopes, where the flow of water is not filtered or captured on the site.
- Earth slides, mudflows, earth sloughing, or other earth movement, which results in material leaving the property.

### **Erosion Control Plan**

A plan containing a list of best management practices (BMP) to be used during construction to control and limit soil erosion.

### **Erosion control, post construction**

The re-establishment of groundcover or landscaping prior to the removal of temporary erosion control measures.

### **Erosion prevention and sediment control**

Measures that are required for construction sites where the ground surface will be disturbed with clearing, grading, fills, excavations, and other construction activities, in order to prevent and/or control eroded material and sediment from leaving the construction site and entering the public stormwater system and/or a water quality resource area.

### **Erosion, visible or measurable**

Includes, but is not limited to: deposits of mud, dirt, sediment, or similar material, exceeding ½ cubic-foot in volume on public or private streets, adjacent property, or into the stormwater system, either by direct deposit, dropping discharge, or as a result of the action of erosion.

### **Excavation**

The mechanical removal of earth material.

### **Fences**

Structures that consist of concrete, brick, wood, plastic, or metal posts located in the ground, connected by wood, metal, or plastic, and capable of allowing passage of water.

### **Fill**

See Clackamas County Water Environment Services definition.

### **Fire hydrant assembly**

The fire hydrant and attached auxiliary valve from a water main to a hydrant.

### **Fire protection service**

A metered connection to the public water main intended only for the extinguishment of fires and the flushing necessary for its proper maintenance.

**Flood or flooding**

A general and temporary condition of partial or complete inundation or normally dry land areas from the overflow of inland or tidal waters, and/or the unusual and rapid accumulation of runoff of stormwaters from any source.

**GIS**

Geographic Information System is a system of hardware and software used for storage, retrieval, mapping and analysis of geographic data.

**Grade**

The degree of inclination of a road or hillside.

**Green Infrastructure.**

A SMF that mitigates stormwater runoff similar to the natural surface hydrological functions through infiltration and/or evapotranspiration, or that involves stormwater reuse.

**Groundwater**

Water found underground in the cracks and spaces of soil, sand and rock.

**Hazardous Materials**

Materials described as hazardous under state and federal law, including, but not limited to, any toxic chemicals listed as toxic under Section 307(a) of the CWA or Section 313 of Title III of the Superfund Amendments and Reauthorization Act (SARA).

**Hearings Officer**

Officer appointed by the General Manager or the Board of Directors, for hearings of appeals of administrative actions.

**Highly Erodible**

Soils with erosion (K) factors greater than 0.25, as listed in the Soil Survey of Clackamas County Area, Oregon, developed by the Soil Conservation Service.

**Impervious areas**

See Design Standards Section 2.

**Improvement**

General term encompassing all phases of work to be performed under a Contract for a Local Improvement OLWS and synonymous with the terms "project" or "work."

**Industrial waste**

Solid, liquid, or gaseous waste resulting from any industrial, manufacturing, trade, or business process due to development, recovery, or processing of natural resources.

**Infiltration System**

A drainage facility designed to use the hydrologic process of stormwater runoff soaking into the ground, commonly referred to as recharge, to dispose of stormwater runoff.

**In-Lieu Fee**

A fee paid to OLWS to cover onsite water quality or water quantity facilities from a site on which Stormwater management is not practical.

**In-Line Detention**

Detention located in a stream channel, a drainageway, or in a regional or subregional piped system. In-line detention mixes flows to be detained with flows from other areas.

**Inspector**

A person authorized by OLWS to inspect construction sites and activities affecting stormwater.

**Installer**

Either the Owner of the property being served or a Contractor doing work in connection with the installation of a Building Sewer or conveyance system under a permit from OLWS, City, or County.

**Interceptor sewer**

The primary public sanitary sewer which conveys wastewater directly into the wastewater treatment plant.

**Intermittent Stream**

A body of running water moving over the earth's surface in a channel or bed, such as a creek, rivulet, or river. A stream flows at least part of the year, including perennial and intermittent streams. Streams are dynamic in nature and their structure is maintained through build-up and loss of sediment.

**Irrigation service**

A metered connection intended for seasonal use and delivering water, which is not discharged to the sanitary sewer.

**Landscape Architect**

A registered professional licensed to practice in the State of Oregon by the Oregon State Board of Landscape Architecture.

**Lateral sewer**

See Rules and Regulations definitions "sewer lateral".

**Longitudinal joint**

A joint which follows a course approximately parallel to the centerline of the roadway.

**Low Impact Development**

A stormwater management approach that seeks to mitigate the impacts of increased runoff and stormwater pollution using a set of planning, design and construction approaches and stormwater management practices that promote the use of natural systems, green infrastructure, and other techniques for infiltration, filtration, evapotranspiration, and reuse of rainwater, and can occur at a wide range of landscape scales (e.g., regional, community and site). Low impact development is a comprehensive

land planning and engineering design approach to stormwater management with a goal of mimicking the pre-development hydrologic regime of urban and developing watersheds.

**Lump sum**

A method of payment providing for one all-inclusive payment for the work described to be done, complete and accepted without further measurement, as such work is covered under the applicable lump sum pay item.

**Manager**

See Rules and Regulations definitions “administrator”.

**Metro**

The Metropolitan Service District organized and operating under ORS Chapter 268 and its Charter in portions of Washington, Multnomah and Clackamas Counties to provide planning and other services.

**Mitigation**

The reduction of adverse effects of a proposed project by considering, in the following order:

- A. Avoiding the impact altogether by not taking a certain action or parts of an action.
- B. Minimizing impacts by limiting the degree or magnitude of the action and its implementation.
- C. Compensating for the impact by replacing or providing comparable substitute Water Quality Resource Areas.
- D. Rectifying the impact by repairing, rehabilitating, or restoring the affected environment.

**Municipal Separate Storm Sewer System (MS4)**

See Design Standards Section 2.

**National Pollutant Discharge Elimination System (NPDES) Permit**

A permit issued pursuant to Chapter 402 of the Clean Water Act (40 CFR 122, 123, 124, and 504).

**Native Vegetation.**

Vegetation native to the Portland metropolitan area provided that it is not invasive non-native or noxious vegetation. See the Portland Plant List maintained by the City of Portland Bureau of Planning and Sustainability.

**Natural drainageway**

A natural depression which collects drainage of surface water. It may be permanently or temporarily inundated.

**Natural grade**

The grade of the land in an undisturbed state.



**Natural resource**

A functioning natural system such as a wetland or stream.

**Natural resource area**

The land containing the natural resources to be protected.

**Non-Single-Family Customer (or User)**

A person or property owner who resides or conducts business or other activities on a parcel that is other than a single-family parcel, including multi-family developments, commercial or industrial zoned parcels.

**Notice**

A written communication delivered, by hand or by mail, to the authorized individual, member of the firm, or officer of the corporation for which it is intended. If delivered or sent by mail it shall be addressed to the last known business address of the individual, firm, or corporation. In the case of a Contract with two or more persons, firms, or corporations, notice to one shall be deemed notice to all.

**OLWS Rules**

OLWS Rules and Regulations, as adopted by the Board.

**On-site detention**

The storage of excess runoff on a development site prior to its entry into a public stormwater drain system. Stored runoff is gradually released after the peak of the runoff has passed.

**Open Space**

1. Land within a development that has been dedicated in common to the ownership within the development or to the public specifically for the purpose of providing places for recreational uses or scenic purposes.
2. Land designated by local, state, or federal agencies for preservation.

**Oregon Standard Specifications for Construction**

The latest edition of the Specification Document published by the State of Oregon.

**Owner**

The owner of record of real property as shown on the latest tax rolls or deed records of the county or a person who furnishes evidence that they are purchasing a parcel of property under a written recorded land sale contract.

**Parcel**

Means the fee title owner of the property that receives services from OLWS.

**Parcel of Land**

A lot, parcel, block or other tract of land that is occupied or may be occupied by a structure or structures or other use, and includes yards and other undeveloped areas required under the zoning, subdivision or other development ordinances.

**Pavement**

Surface to walk, drive or park on that may reduce stormwater runoff by allowing water to soak/infiltrate into the ground. Examples are permeable pavers, pervious concrete, and porous asphalt.

**Peak runoff**

The maximum water runoff rate (cfs) determined for the design storm.

**Perennial Stream**

A permanently flowing (non-intermittent) stream.

**Permit**

Any authorization required pursuant to this or any other regulation of OLWS.

**Permittee**

The person issued a building permit, development permit or any other permit described in this Code is issued.

**Person**

Any individual, firm, company, corporation, partnership association, entity, public corporation, political subdivision, governmental agency, municipality, industry, or any department or agency thereof.

**Pervious Pavement**

Surface to walk, drive or park on that may reduce stormwater runoff by allowing water to soak/infiltrate into the ground. Examples are permeable pavers, pervious concrete, and porous asphalt.

**Perennial Stream.**

A body of running water moving over the earth's surface in a channel or bed, such as a creek, rivulet, or river. A stream flows at least part of the year, including perennial and intermittent streams. Streams are dynamic in nature and their structure is maintained through build-up and loss of sediment.

**Plans**

Construction plans, including system plans, sewer plans, and profiles, cross sections, detailed drawings, etc., or reproductions thereof, approved or to be approved by the District Engineer, which show the location, character, dimensions, and details for the work to be done, and which constitute a supplement to these standards.

**Pollutant**

Any of the following, but not restricted to: oil, grease, soil, mining waste, spoil, solid waste, incinerator residue, sewage, garbage, sewage sludge, munitions, chemical wastes, biological materials, radioactive materials, heat, heavy metals, asbestos, wrecked or discharged equipment, cellar dirt and untreated industrial, municipal and agricultural discharges into water.

**Post-developed Conditions**

Refers to the time period, or conditions that may reasonably be expected or anticipated to exist, after completion of the land development activity on a site.

**Potable water**

Water which is satisfactory for drinking, culinary, and domestic purposes and meets the requirements of the health authority having jurisdiction.

**Practicable.**

Available and capable of being done after taking into consideration cost, existing technology, and logistics in light of overall project purpose.

**Pre-developed**

For new development, pre-developed condition is defined as the condition of land at the time of development. For redevelopment projects, pre-developed condition is defined as the condition of the land before urban development. For the purpose of hydrological evaluations, the pre-developed conditions will be prescribed in the adopted Stormwater Standards.

**Pretreatment Device or Facility**

Any structure or drainageway that is designed, constructed, and maintained to collect and filter, retain, or detain stormwater runoff during and after a storm event for the purpose of water quality improvement.

**Pretreatment**

The reduction of the total suspended solids, including sediments and turbidity-causing materials and the removal of petroleum hydrocarbons, fats, oils, and grease through physical straining, settling processes or filtering of runoff.

**Private collection system**

A privately owned and maintained lateral sewer system installed to serve multi-unit structures on single ownership properties which cannot legally be further divided.

**Private storm drain**

A stormwater drain located on private property serving one or more structures or inlets and is not owned or maintained by OLWS.

**Private Storm System**

That portion of the stormwater system owned and/or maintained by any person or entity other than OLWS and is located outside the public right-of-way, except as otherwise approved by OLWS.

**Professional Engineer (PE)**

A registered professional licensed to practice in the State of Oregon by the Oregon Board of Engineering Examiners. This person is also referred to as the project engineer or the engineer of record.

**Project**

General term encompassing all phases of the work to be performed under the Contract and is synonymous with the term improvement or work.

**Property (or the Site)**

The real property undergoing development.

**Proprietary Stormwater Treatment Device**

A manufactured device, often proprietary, in which stormwater receives treatment before being discharged to the stormwater drainage system, to a SMF, or to the receiving water. This is a broad category of SMFs with a variety of pollutant removal mechanisms and varying pollutant removal efficiencies.

**Provide**

When related to an item of work, the word provide shall be understood to mean furnish and install the work complete in place.

**Public Right-of-Way**

Any public space dedicated to a public transportation agency for ownership and maintenance, such as a county or city owned highway, road, street, avenue, or alleyway. All land or interest therein which by deed, conveyance, agreement, easement, dedication, usage, or process of law is reserved for or dedicated to the use of the general public for roadway purposes, within which OLWS shall have the right to install and maintain public utilities, including sanitary sewers, stormwater, and surface water systems (ORS 758.010). See OLWS Rules.

**Public sanitary sewer**

Sanitary main in public right-of-way or easement operated and maintained by OLWS for carrying sewage and industrial wastes.

**Public storm drain**

Any stormwater sewer in public right-of-way or public easement.

**Public Stormwater**

Public stormwater runoff is defined as flows that include stormwater runoff from public streets that includes, but is not limited to pipes, natural drainageways, creeks, streams and rivers.

**Public Stormwater Easement**

See OLWS Rules for definition of Easement.

**Public Stormwater Mainline**

See the OLWS Rules for Public Mainline. As relates to these Standards, Public Stormwater Mainline refers to the portion of the Public Stormwater System which conveys wastewater through a piping system flowing by gravity.

**Public Stormwater System**

Those portions of the Stormwater system that are in the public ROW or public

easement. These facilities include, but are not limited to: pipes, inlets, catch basins, curbs, ditches, drainageways, berms and other sheet flow and conveyance improvements (such as roadway surfaces), appurtenances and facilities but do not include SMFs.

### **Rational Method**

A formula for estimating maximum discharge of runoff at a point, using flow (Q), runoff coefficient (C), rainfall intensity (I) for selected recurrence interval, and area (A), in the formula:  $Q=CIA$ .

### **Redevelopment**

A project that proposes to add, replace, and/or alter impervious surface (for purposes other than routine maintenance, such as resurfacing) on a site that is already developed.

### **Reference specifications**

Bulletins, standards, rules, methods of analysis or test, codes and specifications of other agencies, engineering societies, or industrial associations referred to in the contract documents. All such references specified herein refer to the latest edition thereof, including any amendments thereto which are in effect and published at the time of advertising for bids or of issuing the permit for the project.

### **Release rate**

The controlled rate of release of drainage, storm, and runoff water from property, storage pond, runoff detention pond, or other facility during and following a storm event.

### **Replaced Impervious Surface**

The removal of an impervious surface that exposes soil, or native subgrade, followed by the placement of an impervious surface is considered Redevelopment of an impervious surface area. Replacement does not include repair or maintenance activities on structures or facilities taken to prevent decline, lapse or cessation in the use of the existing facility or surface, provided the repair or maintenance activity does not expand the coverage of the existing impervious area.

### **Retention**

The process of collecting and holding surface water runoff with no surface outflow.

### **Right-of-way (ROW)**

All land or interest therein which (by deed, conveyance, agreement, easement, dedication, usage, or process of law) is reserved for or dedicated to the use of the public for sidewalk, utility, and/or roadway purposes.

### **Riparian**

Those areas associated with streams, lakes, and wetlands where vegetation communities are predominately influenced by their association with water.

**Roadbed**

Any earthen material below the asphalt or concrete lifts.

**Roadway**

All of that portion of the right-of-way used or to be used for vehicle movement which exists between the curbs, proposed curb lines, or edges of pavement.

**Sedimentation**

Deposition of debris and soil.

**Seasonal High Groundwater.**

The maximum elevation to which the groundwater can be expected to rise due to a normal wet season.

**Sensitive Areas**

Existing or created wetlands, including all mitigated wetlands, Rivers, streams, sloughs, swamps, creeks and impoundments; limits defined by wetlands reports approved by the U.S. Army Corp of Engineers (USACE), Oregon Department of State Lands (DSL), and/or Clackamas County.

**Service Connection**

See the OLWS Rules.

**Sewage**

Water-carried wastes from residences, business buildings, institutions, and industrial establishments, except industrial wastes.

**Sewer Main**

The portion of the public sewerage system which is primarily installed to receive wastewater directly from individual residences and other individual public or private structures.

**Shop drawings and submittals**

Supplementary plans or data or other information which the Contract requires the Contractor to submit to the District Engineer.

**Silt**

Fine textured soil particles, including clay and sand, as differentiated from coarse particles of sand and gravel.

**Siltation**

Deposition of (silt) fine textured waterborne sedimentation.

**Soil**

The upper layer of earth in which plants grow; a black or dark brown material typically consisting of a mixture of organic remains, clay, and rock particles.

**Source Control**

SMFs and/or specific actions taken that attempt to control high risk pollutant loading from entering the stormwater runoff through site activities and site design.

**Special Specifications**

Requirements peculiar to the project and changes and modifications of the Standard Specifications.

**Specified**

As used herein, the word specified, or as specified, means as required by the Contract.

**Standard drawings**

The drawings of structures or devices commonly used on public improvements and referred to on construction plans contained in the OLWS Design and Construction Standards.

**Standard Methods**

The examination and analytical procedures set forth in the most recent edition of Standard Methods for the Examination of Water and Wastewater, published by the American Public Health Association, AWWA, and Water Environment Federation.

**Standard Specifications**

The terms, directions, provisions and requirements set forth herein.

**Station**

A distance of 100 feet measured horizontally along the established centerline of a street, sewer, or other work, unless specified otherwise.

**Stop Work Order**

An Order issued by OLWS for violation of the Rules and Regulations. All work contributing to the violation must cease when a Stop Work Order is issued, and the Stop Work Order will stay in place until such time as removed by OLWS in writing.

**Storm Sewer System**

Those portions of the stormwater system that are in the public ROW or public easement and on private property. These facilities include, but are not limited to: pipes, inlets, catch basins, curbs, ditches, drainageways, berms and other sheet flow and conveyance improvements (such as roadway surfaces), appurtenances and facilities and do include SMFs.

**Stormwater**

Waters on the surface of the ground or underground resulting from precipitation.

**Stormwater Mainline**

The portion of the Stormwater System which conveys stormwater through a piping system flowing by gravity. It can be publicly or privately-owned.

**Stormwater Management (SWM)**

A program to provide surface water quality and quantity controls through nonstructural

methods and capital improvement projects. Nonstructural controls include maintenance of surface water facilities, public education, water quality monitoring, implementation or intergovernmental agreements to provide for regional coordination, and preparation of water quality control ordinances and regulations. Stormwater Management is also referred to as “surface water management”.

**Stormwater Management Facility (SMF)**

Any facility that is designed, constructed, and maintained to collect, treat, filter, retain, or detain surface water runoff during and after a storm event for the purpose of controlling flows and/or reducing pollutants in stormwater runoff. SMFs include, but are not limited to constructed wetlands, rain gardens, water quality swales, stormwater planters, infiltration facilities, and ponds. SMFs can be privately or publicly owned and maintained.

**Stormwater Management Plan**

A plan that is stamped by a Professional Engineer (PE) and contains specific information regarding plans to locate and construct SMFs and stormwater drainage systems to meet OLWS performance and design standards.

**Stormwater Quality Treatment Facility**

See SMF.

**Stream**

A drainageway that is determined to be jurisdictional by the USACE or DSL, also referred to as creek.

**Structures**

See Design Section 2.

**Subcontractor**

An individual, partnership, firm, corporation, or any combination thereof, to whom the Contractor sublets part of the Contract.

**Substantial completion**

The work (or a specified part thereof) has progressed to the point where, in the opinion of the District Engineer, it is sufficiently complete in accordance with the contract documents and/or conditions of approval, so that the work (or specified part) can be utilized for the purposes for which it is intended.

**Surety**

The corporate body which is bound with and for the Contractor, for the acceptable performance of the Contract, and for their payment of all obligations arising out of the Contract.

**Top-of-bank**

The point closest to the boundary of the active floodplain of a stream where a break in the slope of the land occurs such that the grade beyond the break is flatter than 3:1 at any point for a minimum distance of 25 feet measured perpendicularly from the break.



**Transverse joint**

A joint, which follows a course approximately perpendicular to the centerline of the roadway.

**Treatment**

The reduction of the amount of pollutants, the elimination of pollutants, or the alteration of the nature of pollutant properties in water to a less harmful state prior to discharging to Waters of the State.

**Trunk sewer**

(Interceptor) A sanitary sewer which is primarily intended to receive wastewater from a collector sewer, another trunk sewer, an existing major discharge of raw or inadequately treated wastewater, or water pollution control facility.

**Undeveloped Land**

Land left in its natural state, free from any structures, roadways, placement of impervious materials or any other man created alteration.

**Uniform Plumbing Code**

The Uniform Plumbing Code adopted by the International Association of Plumbing and Mechanical Officials (current edition), as revised by the State of Oregon, called the "Oregon State Plumbing Specialty Code".

**Unit price**

A contract item of work providing for payment based on specific unit of measurement; e.g., linear foot or cubic yard.

**User**

Any person or entity in whose name service is rendered as evidenced by the signature on the application or contract for that service, or in the absence of a signed instrument, by the receipt and payment of utility bills regularly issued in his/her/its name. A user, under this system and structure of rates, is either single-family or non- single-family.

**User – Non-Single-family**

Any user whose impervious surface results from the development of land for purposes of operating a dwelling unit for occupancy by more than one single-family or for other business, industrial, commercial or institutional purposes and to whom utility services are provided at a distinct service location

**Utility Facilities**

Buildings, structures, or any constructed portion of a system that provides for the production, transmission, conveyance, delivery, or furnishing of services including, but not limited to, heat, light, water, power, natural gas, sanitary sewer, stormwater, telephone, and cable television. Utility facilities do not include stormwater pretreatment facilities.

**Variance**

A discretionary decision to permit modification of the terms of any part of this Code based on a demonstration of unusual hardship or exceptional circumstance unique to a specific property.

**Vegetated Corridor**

See the Clackamas County Definition.

**Virtual Connection**

A change in “service class” or occupancy or operational change which results in an increase in wastewater volume, strength or load using the existing sewer lateral or service line. Typically, these are tenant improvements or accessory dwelling units, but could also be commercial/industrial process changes.

**Wastewater**

The total fluid flow in the sanitary sewerage system which includes industrial waste, sewage, or any other waste (including that which may be combined with any ground water, surface water, or stormwater) that may be discharged into the sanitary sewerage system.

**Water distribution system**

Water pipelines, pumping stations, reservoirs, valves, and ancillary equipment used to transmit water from a supply source through a service meter.

**Water main**

A water supply pipe for public use.

**Water Quality Facility**

A facility specifically designed for pollutant removal.

**Water Quality Standards**

The Federal Clean Water Act, the Code of Federal Regulations, ORS Chapter 468 and OAR Chapter 340 Division 41.

**Water service line**

The pipe connection from OLWS water main to the users' water meter, hydrant, backflow prevention device, or fire sprinkler double check valve.

**Waters of the State**

Those waters defined in ORS Chapter 468B.005, or as amended, which include lakes, bays, ponds, impounding reservoirs, springs, wells, rivers, streams, creeks, estuaries, marshes, inlets, canals, the Pacific Ocean within the territorial limits of the State of Oregon, and all other bodies of surface or underground waters, natural or artificial, inland or coastal, fresh or salt, public or private (except those private waters which do not combine or effect a junction with natural surface or underground waters), which are wholly or partially within or bordering the state or within its jurisdiction.

**Water Treatment Bioswale/Water Quality Swale**

A vegetated natural depression, wide shallow ditch, or similar constructed facility used to filter runoff for the purpose of improving water quality.

**WES**

Clackamas County Water Environment Services is the wastewater and surface water management agency for Clackamas County

**Wetland**

Areas that are inundated or saturated by surface or groundwater at a frequency and duration sufficient to support and that under normal circumstances do support a prevalence of vegetation typically adapted for life in saturated soil conditions. Wetlands are those areas identified and delineated by a qualified wetlands specialist as set forth in the Federal Manual for Identifying and Delineating Jurisdictional Wetlands, January 1987, or by a DSL/COE 404 permit. Wetlands may also consist of:

1. **Constructed Wetlands.** As defined in Section 404 of the Clean Water Act, constructed wetlands are those areas developed as a water quality or quantity facility, subject to maintenance as such. These areas must be clearly separated from existing or created wetlands.
2. **Created Wetlands.** Created wetlands are those wetlands developed in an area previously identified as a non-wetland to replace or mitigate wetland destruction or displacement.
3. **Existing Wetlands.** Wetlands identified and delineated as set forth in the Federal Manual for Identifying the Delineating Jurisdictional Wetlands, January 1987, or as amended, by a qualified wetlands specialist.

**Wet Weather**

The portion of the year when rainfall amounts and frequency tend to have the most significant effect on erosion prevention and sediment control (October 1 to May 31).

**Work**

All material, labor, tools, equipment, and all appliances, machinery, transportation, and appurtenances necessary to perform and complete the Contract, and such additional items not specifically indicated or described which can be reasonably inferred as belonging to the item described or indicated and as required by good practice to provide a complete and satisfactory system or structure.

**Work Area**

Areas of disturbance for activities defined under “Development”. Work Area includes areas used for storage of equipment or materials that are used for these activities.

**Working day**

Calendar day, any and every day shown on the calendar, excluding Saturdays, Sundays and legal holidays.

### 1.0.9.02 Abbreviations

|         |  |
|---------|--|
| AAN     | American Association of Nurserymen                                 |
| AASHTO  | American Association of State Highway and Transportation Officials |
| ACI     | American Concrete Institute  |
| AGA     | American Gas Association   |
| AGC     | Associated General Contractors of America                          |
| AIA     | American Institute of Architects                                   |
| AISC    | American Institute of Steel Construction                           |
| AISI    | American Iron and Steel Institute                                  |
| ANSI    | American National Standards Institute                              |
| APWA    | American Public Works Association                                  |
| ASCE    | American Society of Civil Engineers                                |
| ASME    | American Society of Mechanical Engineers                           |
| ASTM    | American Society for Testing and Materials                         |
| AWPA    | American Wood Preservers Association                               |
| AWS     | American Welding Society   |
| AWWA    | American Water Works Association                                   |
| BMP     | Best Management Practices  |
| CCDTD   | Clackamas County Department of Transportation and Development      |
| CFR     | Code of Federal Regulation   |
| CFS     | Cubic feet per second  |
| CKD     | Cement kiln dust   |
| CLSM    | Controlled low strength material.                                  |
| CMP     | Corrugated metal pipe  |
| CN      | Curve numbers  |
| CRSI    | Concrete Reinforced Steel Institute                                |
| CTB     | Cement treated base  |
| DEQ     | Oregon Department of Environmental Quality                         |
| DSL     | Oregon Department of State Lands                                   |
| DTD     | Clackamas County Department of Transportation and Development      |
| EPA     | Environmental Protection Agency                                    |
| EPSC    | Erosion Prevention and Sediment Control                            |
| FEMA    | Federal Emergency Management Agency                                |
| FPS     | Feet per second  |
| GIS     | Geographic Information System                                      |
| GULD    | General Use Level Designation                                      |
| H:V     | Horizontal to vertical   |
| HDPE    | High density polyethylene pipe                                     |
| HEC-RAS | Hydrologic Engineering Centers – River Analysis System             |
| HGL     | Hydraulic grade line   |
| IE      | Invert elevation   |
| ITE     | Institute of Traffic Engineers                                     |
| MS4     | Municipal Separate Storm Sewer System                              |
| NEC     | National Electrical Code   |

|       |   |
|-------|---|
| NEMA  | National Electrical Manufacturer's Association  |
| NLMA  | National Lumber Manufacturer's Association      |
| NPDES | National Pollutant Discharge Elimination System |
| NRCS  | National Resource Conservation Service          |
| O&M   | Operations and Maintenance                      |
| OAR   | Oregon Administrative Rules                     |
| ODFW  | Oregon Department of Fish and Wildlife          |
| ODOT  | Oregon Department of Transportation             |
| OLWS  | Oak Lodge Water Services                        |
| OPSC  | Oregon Plumbing Specialty Code                  |
| ORS   | Oregon Revised Statutes                         |
| OSHA  | Occupational Safety and Health Administration   |
| OSHD  | Oregon State Highway Division                   |
| OSSC  | Oregon Standard Specifications for Construction |
| PCA   | Portland Cement Association                     |
| PDF   | Portable Document Format                        |
| PE    | Professional Engineer                           |
| PPM   | Parts per million                               |
| PSI   | Pounds per square inch                          |
| PVC   | Polyvinyl chloride                              |
| ROW   | Right of Way                                    |
| SBUH  | Santa Barbara Urban Hydrograph                  |
| SDR   | Standard Dimensional Ratio                      |
| SMF   | Stormwater Management Facility                  |
| SWM   | Stormwater Management                           |
| SWMM  | Stormwater Management Model                     |
| SU    | Standard Units                                  |
| TAPE  | Technology Assessment Protocol - Ecology        |
| Tc    | Time of Concentration                           |
| TSS   | Total Suspended Solids                          |
| UBC   | Uniform Building Code                           |
| UIC   | Underground Injection Control                   |
| UL    | Underwriters' Laboratories, Inc.                |
| UPC   | Uniform Plumbing Code                           |
| USACE | United States Army Corps of Engineers           |
| USASI | United States of America Standards Institute    |
| WES   | Clackamas County Water Environment Services     |
| WPCF  | Water Pollution Control Facility                |
| WQRA  | Water Quality Resource Area                     |
| WWPA  | Western Wood Products Association               |

## 1.1 CONSTRUCTION PLANS

---

### 1.1.1 General Information

Prior to any construction work and plan approval, complete construction plans, specifications and all other necessary submittals shall be submitted to the District Engineer for review. Submittal requirements consist of design plans (where required), drainage calculations, and other information as necessary. Conditions of approval from the Development Plan Review process, or as specified by OLWS, the Clackamas County Planning Commission, Hearings Officer or the Planning Director shall all be shown on the design plans.

### 1.1.2 Plan Preparation

Construction plans and specifications shall be prepared by a professional engineer licensed by the State of Oregon, as specified in Subsections 1.1020 (Plan Preparation) and 1.1030 (Required Sheets).

Typical permit submittal items include:

- Complete OLWS Plan Review Application Form (online submittal)
- Preliminary Site Plan: A site plan containing proposed sanitary sewer, water and / or stormwater facilities
- Details
- Profile plans
- Fees and charges
- Drainage Fixture schedule
- Statement of occupancy(ies) for any and all relevant structures with water and sanitary sewer connection.
- Note, all submitted Site plans, grading plans, stormwater drainage plans, and associated calculations must be stamped and signed by a professional engineer licensed by the State of Oregon and meet the standards of OLWS.
- Engineer's statement (calculation) of disturbed area.
- Engineer cost estimate of water / sanitary sewer / stormwater facilities including installation
- Downstream analysis.
- Preliminary and final plat
- Utility maintenance agreement(s)
- Geotechnical Report / Soil Report / Infiltration Analysis (from a professional geotechnical engineer or geologist).
- Stormwater Report
- Erosion Prevention / Sediment Control plan and details and narrative
- Performance bond
- Warranty bond
- DEQ Approval letter
- As-builts for any site work.

### 1.1.2.01 Sheet Size

All construction plans shall be clearly and legibly drawn in ink "D"- size sheets. Sheets shall have a 1½-inch clear margin on the left edge and a ½-inch margin on all other edges.

### 1.1.2.02 Scale of Plans

The following are applicable to engineering drawings for plan review and as-builts.

When plans are prepared for developer financed projects, the scale of drawings shall be as follows. Horizontal scales shall be 1" = 40', or 50', vertical scales shall be 1" = 2', 4', 5', or 10'. For subdivision plans it is preferred that all plan views and profile views of the plan set are drawn at a common scale, if more than one scale is necessary, the difference should be large enough to be noticeable (e.g. 1" = 20' & 1" = 50'). When a scale is used which is smaller than 1" = 20' (e.g. 1" = 40') intersection details showing fittings and valves shall be provided at a larger scale. Architectural scales (e.g., ¼" = 1'0") are not permitted unless approved. Letter size shall not be smaller than 0.10 inches.

Sheets shall contain a maximum of one plan view and one profile per sheet. The stations must align on the plan view and profile view and of a corresponding scale. The sheet coverage ratio should be no less than 60% plan view and 40% profile.

## 1.1.3 Required Sheets

Construction plan submittals shall contain the following minimum sheets: title sheet (unless not required by the District Engineer) plan and profile sheet(s), and detail sheet(s). A title block shall appear on each sheet of the plan set and shall be placed on the lower right-hand corner of the sheet, across the bottom edge of the sheet or across the right-hand edge of the sheet. The title block shall include the names of the project, the engineering firm, the owner, the sheet title, page, and revision number and dates.

The seal and signature of the Design Engineer responsible for preparation of the plans shall appear on each sheet as well as the Design Engineer's phone number. The description and date of all revisions to the plans shall be shown on each sheet affected and shall be approved and dated by the Design Engineer as evidenced by signature or initial.

### 1.1.3.01 Title Sheet

All subdivision projects and multiple sheet improvement projects shall have a title sheet as the first page of the construction plans. This sheet shall contain the following minimum information.

1. Site plan of entire project with street right-of-way and/or subdivision layout at a 1" = 100' scale. A 1" = 200' scale may be used if project size is too large. The site plan shall also be a composite utility plan showing all properties served by

- proposed sewer, water, and stormwater facilities, in addition to the proposed facility.
2. Vicinity map at a 1" = 1000' scale or greater. Map shall show the location of the project in respect to the nearest major street intersection.
  3. Index of sheets.
  4. Complete legend of symbols used.
  5. General and construction notes pertinent to project, space permitting. If space does not permit a separate note page shall be used.
  6. Temporary and/or permanent benchmarks used along with their descriptions, elevations of benchmark, and datum.
  7. Design Engineer's name, address, phone number, and seal.
  8. Developer's/owner's name, address, and phone number for public improvements with private financing.
  9. Statement referencing OLWS Infrastructure Design and Construction Specifications.
  10. Provide contact phone number for all affected utility companies.
  11. Show tax lot numbers or lot and block designations.
  12. Conditions of approval.

#### **1.1.3.02 Plan Sheet**

The plan view of each sheet shall be drawn at the appropriate scale showing the following minimum information.

1. Adjacent street curbs, property lines, right-of-way lines, utility easements referenced to property lines, street centerlines, and intersections. Show property corner and curb elevations to determine water service level, serviceability of lot/property for sanitary sewer, points of disposal for building stormwater drains, and how new curbs will join to existing curbs. Include existing topographical map with 2' contour intervals; slopes over 10% may use 5' intervals; extend contours a minimum of 100 feet beyond property and finished contours of the property, after development, at 2' or 5' intervals as required and percent grade for graded slopes; elevations, dimensions and locations for all graded slopes.
2. Location of all underground utilities within 100 feet of project (if they are affected by the project), existing power/telephone poles and guy anchors, valves, manholes, catch basins, fire hydrants, meter boxes and vaults, signs, etc.
3. Location of all water courses, subsurface water outlets (e.g. springs), railroad crossings, culverts, bridges, large water transmission pipes and gravity sewers, and/or stormwater drains within 200 feet of proposed gravity sewer and stormwater drain extensions if they affect the design of the project. All water courses shall show the 100-year flood plain as indicated on the U.S. Army Corps of Engineers and Federal Emergency Management Agency (FEMA) maps.
4. On sewer and stormwater drain plans, each manhole, catch basin, and cleanout shall be numbered and stationed. Station numbering shall tie to existing street



- monuments, property corners, or manholes. Each separate line shall be separately designated (e.g., sewer line 'A', storm line 'A', etc.).
5. On street plans, horizontal stationing shall show points of tangency and curvature for centerline; curve data shall show tangent length, radius distance, centerline curve length, and delta angle. Centerline intersection stationing, in both directions, shall be shown.
  6. Where streets are being widened, edge of pavement elevations shall be shown to determine pavement cross-slope to new curb or pavement edge.
  7. On water plans, show all fittings and valves and identify by type (e.g., MJ x MJ, FLG x MJ, etc.); fire hydrants; intersection details for valves and fittings
  8. On all plans, show stub-outs and block-outs for future developments.
  9. On composite utility plans, if individual sheets are not provided, all utilities and associated lines, appurtenances and fittings, and associated callouts and notes must be colored to their utility locate color. For example, sanitary sewer = green, potable water = blue, and pink for stormwater sewer and stormwater.
  10. All proposed drainage facilities - including but not limited to public and private systems; show all paved areas, curbs, sidewalks; drainage ditches, culverts. Include Cut/fill areas; structural fill placement areas; erosion/sedimentation control methods; reseeding areas and on-site basin plan showing drainage areas with respective treatment facilities. (For example, the drainage area for each proposed swale, and/or catch basin, and/or inlet, and/or mechanical filter, and/or outlet.)
  11. All corrections to plan review comments must be identifiable by being "clouded" or otherwise "called out" on the plans with the associated revision number.
  12. All revisions must be labeled with the revision number and associated drawing date.

### **1.1.3.03 Profile Sheet**

Profiles for construction plans shall be the same horizontal scale as the plan sheet. Where profiles are drawn on the same sheet as the plan view, the profile shall be immediately below the plan view. The following minimum information shall be shown.

1. For sewers and stormwater drains, show locations of manholes, catch basins, and cleanouts, with each numbered and stationed as indicated in Subsection 1.1.3.02 (Plan Sheet) item 4.
2. Existing profile at centerline of proposed utility or street. Profiles at the right-of-way lines will be required if grade differences are significant.
3. Proposed profile grade, as appropriate, for all sewers, stormwater drains, and waterlines, giving pipe size, length between structures or fittings, slope, backfill and pipe material, sewer inverts, rim elevations, etc. Extension of the profile of streets for future extensions (stub streets) will be extended at least 200 feet for local streets or as required by the District Engineer.
4. Existing underground utilities that cross the alignment of the proposed facility.

5. Beginning of all vertical curves, points of vertical intersection, end of vertical curve, low point of sag curve, and length of vertical curve. Profiles of existing centerline grade shall extend a minimum of 250 feet beyond the end of the improvement.
6. Clearly show all potential conflicts with existing public and private utilities (i.e., pipes, conduits, vaults, cathodic protection systems, etc.) that impact proposed design.
7. Profiles for ditch and creek flowlines shall extend a minimum of 200 feet beyond the project, both upstream and downstream. Typical cross sections at 50-foot intervals shall also be submitted.

**SPECIAL NOTE:** OLWS As-builts are only to be used as an aid to the engineer. When a potential conflict may occur, the Design Engineer shall field locate, or cause to be located, and verify the alignment, depth, and inverts of all existing facilities shown on the plans that will be crossed by the proposed facility.

#### **1.1.3.04 Detail Sheets**

Detailed drawings shall be included with all construction plans where OLWS standard drawings do not exist. If a standard drawing, such as sewer manholes, must be modified to fit existing or unique conditions, the modified drawing shall be shown on the plans. When appropriate, due to required detail complexity, a separate detail sheet shall be drawn. When OLWS standard drawing appurtenances or construction installations are to be used, a reference to the specific standard drawing number shall be made on the title sheet.

### **1.1.4 Supporting Information**

The Design Engineer shall submit sufficient supporting information to justify the proposed design. Such information shall include, but not be limited to, the following:

1. Design calculations.
2. Hydrology and hydraulic calculations with basin maps.
3. Alternate materials specifications including manufacturer's design application recommendation.
4. Grading plan support information to include as appropriate.
  - a. Soils classification report
  - b. Hydrology report
  - c. Geotechnical engineer's report

#### **1.1.4.01 Facility Plan**

When designing sanitary or stormwater sewer facilities, a facility plan shall be submitted with the construction plans when required by the District Engineer. This plan shall be used to identify and analyze the proposed extension of facilities. The topographic plan shall show all upstream and tributary areas within no less than 200 feet of the proposed development.

The plan shall include existing contours at 2-foot intervals, or as approved by OLWS, including location of existing structures and public and private utilities.

For water quality facilities, the plan shall also include:

- Design Engineer that certification that the proposed water quality facilities have been designed to meet the stormwater management requirements in Section 2.0002.
- A financial assurance, meeting the requirements of the community development code is provided for the construction of the water quality facility.
- An operation and maintenance plan shall be prepared showing how the water quality facility is to be maintained.
- A landscape plan shall be prepared for the proposed facility.
- A list of recommendations by a Geotechnical Engineer may be required at the discretion of the District Engineer.

#### **1.1.4.02 Erosion Prevention and Sediment Control Plan**

An EPSC Plan shall be prepared in accordance with the requirements of the most current version of the Erosion Prevention and Sediment Control Planning and Design Manual adopted by OLWS and these Standards for all sites where an EPSC Permit is required.

The erosion control plan shall address the measures as required by the Erosion Prevention and Sediment Control Plans, Technical Guidance Handbook (ECTGH) (Clackamas County Department of Utilities, 2001)<sup>1</sup>. Construction projects beginning prior to May 1 or those projects anticipating construction activity between November 1 and April 30 will be required to submit a plan addressing "wet weather" measures as outlined in the ECTGH. Construction activity is assumed as "active" until all permanent vegetation and/or erosion protection is established.

The plan shall include existing contours at 2-foot intervals, or as approved by OLWS, including location of erosion control facilities (i.e., silt fence, straw mulch, sediment ponds, etc.); outlet structures (i.e., catch basins, culverts, creeks, etc.); and existing public and private utilities.

#### **1.1.4.03 Information Required on Erosion Control Drawings**

The following items must be depicted on ESCP drawings, as applicable:

- a. Total property boundary including surface area of the development.

---

<sup>1</sup> Or current edition.

- b. Areas of soil disturbance (including, but not limited to, showing cut and fill areas and pre-and post-development elevation contours);
- c. Drainage patterns before and after finish grading;
- d. Discharge points;
- e. Areas used for the storage of soils or wastes;
- f. Areas where vegetative practices are to be implemented;
- g. All erosion and sediment control measures or structures;
- h. Identify the type of seed mix (percentages of the various seeds of annuals, perennials and clover) and other plantings.
- i. Critical riparian areas, sensitive preserved vegetative areas, including trees and their root zones.
- j. Runoff controls to minimize erosion and scour. BMPs such as, diversion, slope drains, diversion dikes, check dams and drainage swales.
- k. Stabilized site entrances and access roads including, but not limited to construction entrances, roadways and equipment parking areas (for example, using geotextile fabric underlay).
- l. Perimeter sediment control, including stormwater drain inlet protection as well as all sediment basins, traps, and barriers.
- m. Stockpile management, including dust control and location.
- n. Concrete truck and other concrete equipment washout areas.
- o. Impervious structures after construction is completed (including buildings, roads, parking lots and outdoor storage areas);
- p. Springs, wetlands and other surface waters on site or adjacent to the site;
- q. Temporary and permanent stormwater conveyance systems;
- r. Onsite water disposal locations (for example, for dewatering);
- s. Stormwater drain catch basins depicting inlet protection, and a description of the type of catch basins used (for example, field inlet, curb inlet, grated drain and combination);
- t. Septic drain fields;
- u. Existing or proposed drywells or other UICs;
- v. Drinking water wells on site or adjacent to the site;
- w. Planters;
- x. Sediment and erosion controls including installation techniques;
- y. Natural buffer zones and any associated BMPs for all areas within 50 feet of a waters of the state; and
- z. Detention ponds, stormwater drain piping, inflow and outflow details.

**Narrative Site Description:** Describe the nature of the construction activity and the final use of the site, that is what will the site be used for at the completion of the construction. The narrative shall also contain the following:

**Water Quality Requirements for TMDL and 303(d) Listed Waterbodies.** If there is a potential for discharge of stormwater to directly discharge or discharge through a conveyance system to a portion of a waterbody that is listed for turbidity or

sedimentation or that has an established Total Maximum Daily Load (TMDL) for sedimentation or turbidity from the construction site, then one or more of the BMPs listed below must be implemented. Identify the selected BMP(s) in the ESCP as one that addresses this condition of the permit, and provide the rationale for choosing the selected BMP(s). The 303(d) list can be found at: the Oregon DEQ website. Search under Category 5 (303(d)) and Category 4a (TMDL approved). If none, state “no water quality requirements” on the narrative.

**Inspector Qualification Information:** Provide the following information on the Erosion and Sediment Control Inspector. This is a person that works for the applicant and not a government employee. The consultant, general contractor, project manager, or person who prepared the ESCP may be designated with their agreement as the initial or final ESC Inspector. Upon designating an inspector(s), submit to OLWS their name(s), and contact information including the following:

- Any Erosion Control Certification Information (E.g. CESCL, CPESC or equivalent)
- Application Date;
- Project Name;
- Plan Prepared By;
- Company Name;
- E-mail Address; and
- Emergency Phone Number.

**Natural Buffer Zone**

If a “waters of the state” is within the project site or within 50 feet of the project boundary, and a natural buffer exists within 50 feet of the water of the state, the ESCP must delineate and protect this area with orange fencing or flagging and maintain existing buffer until completion of project. All discharge must be filtered prior to entering the natural buffer to avoid sediment build up. If scour is an issue, an energy dissipater may need to be installed.

Natural Buffer means, for the purposes of this permit, an area of undisturbed natural cover surrounding surface waters within which construction activities are restricted. Natural cover includes the natural vegetation, exposed rock, and barren ground that existed prior to commencement of earth-disturbing activities.

If project will reduce natural buffer zone under 50 feet of waters of the state, the ESCP must include one or more of the following BMPs to control and treat sediment and turbidity:

- Compost berms, compost blankets, or compost socks;
- Erosion control mats;
- Tackifiers used in combination with perimeter sediment control BMPs;
- Water treatment by electro-coagulation, flocculation, filtration; or
- Other substantially equivalent sediment or turbidity BMP approved by DEQ or Agent

If no natural buffer zone(s) will be affected by the project, on the narrative state the following: “no natural buffer zone impacts will be realized by the proposal.”

**Additional Information:** OLWS may also require the applicant to provide additional information as indicated in these Standards or the Rules and Regulations.

Supplemental Plans can include:

### **Maintenance and Removal of Stormwater Best Management Practices**

The Permittee shall maintain the BMPs contained in the approved EPSC Plan to continue to be effective during the construction phase, post construction phase, establishment of permanent vegetation, or any other permitted activity. If the BMPs approved in an EPSC Plan are not effective or sufficient as determined by OLWS site inspection, the Permittee shall submit a revised plan within three (3) working days of written notification by OLWS. Upon approval of the revised plan by OLWS, the Permittee shall immediately implement the additional BMPs included in the revised plan. In cases where erosion is likely to occur, OLWS may require the Applicant to install interim control measures prior to submittal and/or approval of the revised EPSC Plan.

Temporary BMPs, such as sediment fences, shall be removed after permanent vegetation is established.

### **Wet Weather Stabilization**

Where natural vegetation has been removed, or the original land contours disturbed, vegetative ground cover shall be planted and established by October 1 and continue to function through May 31 of the following year, or as approved by OLWS. If ground cover is not established by October 1, the open areas shall be protected through May 31 of the following year with straw mulch, erosion blankets, or other methods approved by OLWS. The site shall be revegetated per a submitted and approved seeding and maintenance plan as soon as practicable after construction has commenced, but not later than September 1. After that date, a stabilization plan approved by OLWS must be used.

### **Contaminated Soils**

In the event the construction process reveals soils contaminated with hazardous materials or chemicals, all parties shall stop work immediately, ensure no contaminated material is hauled from the site, remove work forces from the immediate area of the contamination, leaving all machinery and equipment, and secure the area from access by the public until such time as a response team has evaluated the situation and identified an appropriate course of action. The Applicant and the Contractor shall notify OSHA and DEQ of the situation upon discovery. The Applicant and the Contractor must comply with OSHA and DEQ statutes and rules.

### **Mass Grading and Runoff Control**

A phased mass grading and runoff control plan is required for projects where clearing and mass grading activities are proposed during Wet Weather. The runoff control plan shall identify BMPs from Section 8.6.3, Table 15, or approved alternatives, and be

submitted with, or as a revision to, the EPSC Plan. All stormwater BMPs specified on the runoff control plan shall be in place and functional prior to commencement of mass grading.

### **Dewatering**

A dewatering plan is required for projects with anticipated excavation activities at or below the ground water table, or if ground water is encountered during construction. The supplemental plan shall be submitted with, or as a revision to, the EPSC Plan and shall identify how dewatering discharges will be managed.

### **Cement Treatment**

A cement treatment plan is required for projects where cement treatment is proposed as a soil amendment (including, but not limited to Portland cement-treated base [CTB], cement kiln dust [CKD], or fly ash). The supplemental plan shall indicate an application rate, work schedule, and limits of work areas proposed for cement treatment. If cement treatment will occur during Wet Weather, the following conditions will also apply:

- A. The project shall be phased in small manageable areas to minimize the risk for erosion.
- B. Contractor shall have sufficient erosion prevention stormwater BMPs on site to cover all exposed soil.
- C. Each phase must be stabilized with temporary or permanent erosion prevention stormwater BMPs before disturbing additional phases.
- D. The plan shall indicate how runoff from areas treated with cement will not cause or accelerate erosion of soils not treated with cement.
- E. If the runoff has a high pH (8.5 standard units or higher) then the plan must include an engineered sediment basin or similar impoundment must be used for treatment before discharge. The operator is required to determine the acceptable pH water quality criteria range of site discharge based on criteria of the receiving waterbody according to OAR 340-041-0021. If necessary, the operator must adjust or neutralize the high pH water until it is in the range of pH Standard Units (SU) using an appropriate treatment BMP such as carbon dioxide (CO<sub>2</sub>) sparging or dry ice. The operator must conduct and document pH monitoring of stormwater captured in the sediment impoundment as described below:
  - a. The operator must begin the pH monitoring period when the engineered soils are first exposed to precipitation and must continue every 7 calendar days and within 24 hours of the occurrence of discharge from the site, or the occurrence of a storm event of 0.10-inches or greater until final stabilization of the area of engineered soils is established.
  - b. Document date soil amendments were added and final stabilization achieved in the Inspection Reports.
  - c. The operator must monitor the pH of stormwater in the sediment basins/impoundments and at discharge point locations that receive stormwater runoff from the area of engineered soils before the stormwater discharges to surface waters. Testing shall be done by an approved method

and protocol and be performed by an operator knowledgeable in the testing method.

- d. The benchmark value for pH is defined in SU and determined by the river basin containing the receiving waterbody according to OAR 340-041-0021. Anytime monitoring indicates that the pH is the maximum allowed SU or greater, the operator must either:
  - i. Prevent the high pH water from entering stormwater sewer systems or surface waters; or
  - ii. If necessary, adjust or neutralize the high pH water until it is in the range of pH SU acceptable for discharge to the river basin containing the receiving waterbody by using an appropriate treatment BMP such as carbon dioxide (CO<sub>2</sub>) sparging or dry ice. The operator must obtain written permission from OLWS (and/or other authorities as applicable) before using any form of chemical treatment other than CO<sub>2</sub> sparging or dry ice.
- F. If visible or measurable erosion is occurring, all cement treatment activities shall be suspended, and approved erosion prevention facilities shall be applied to all exposed soil.

### **Chitosan Treatment Systems**

Chitosan treatment plan is required where chitosan is proposed as a BMP. The supplemental plan must include a statement of the intent to use chitosan, the reason for its use and the name, experience and training of the qualified operator who will be monitoring the use of chitosan. Additional requirements are dependent on the form of chitosan proposed, as detailed below:

- A. If chitosan acetate is proposed, the system must be a chitosan enhanced sand filtration system. The supplemental plan must demonstrate that the system is consistent with the protocol outlined in Ecology's GULD for chitosan enhanced sand filtration.
- B. If chitosan lactate (cartridge) is proposed, the system shall be designed by a registered PE to meet site specific conditions and comply with the manufacturer's recommendations. A supplemental plan must include the following:
  - a. Location and design schematic of treatment system, location of inlet and location of discharge and dispersion device design.
  - b. Method for ensuring filtration or settlement of treated stormwater to comply with the following discharge standards:
    - i. Residual chitosan must not exceed 1 mg/L,
    - ii. Turbidity must not exceed DEQ's Water Quality Standards, and
    - iii. pH must remain within a range of 6.5-8.5
- C. Qualified operator inspection and certification of consistency with the design, prior to system operation and use.
- D. Testing and monitoring protocol, including at minimum:



- a. Qualified operator must field test discharge using a Residual Chitosan Lactate Field Screening Test Kit, or OLWS approved equal.
- b. Field tests shall be performed during the first discharge of treated water and weekly thereafter for as long as chitosan is being used.
- E. Response protocol, if field testing demonstrates exceedance of discharge standards, including immediate notification to OLWS, modification to the treatment system, and implementation of additional erosion control facilities.
- F. Notification protocol to OLWS if any modifications to the treatment system are made.
- G. Maintenance protocol of treatment system

### **1.1.5 Plan Submittal and Review Procedures**

For all utility or erosion control permit reviews, the property owner shall make a relevant application to OLWS. This submittal is separate from the Clackamas County or other Agency or OLWS submittal. Other agencies such as Clackamas County do not provide application materials to OLWS. The applicant or property owner must submit to OLWS separately.

Construction plans for all privately financed Infrastructure facility improvements shall be submitted to the District Engineer. The District Engineer will coordinate the plan review and approval of all construction plans which will include review for compliance with all OLWS Infrastructure Standard Construction Specifications, rules, and the project conditions of approval.

All plan submittals shall include information required in Subsection 1.1.4 (Supporting Information) along with all other information requested by the District Engineer. This information is to include, but not be limited to, construction cost estimates, easement documents, right-of-way dedications, executed agreements, and a plan check and inspection fee. All submittals will be reviewed for completeness and the Design Engineer notified if required information is missing. Submittals should be made in a timely manner as lack of information to OLWS may impede the review process.

Plans and documents shall be submitted electronically through OLWS permitting software system. A complete construction cost estimate will be submitted for review and determining review fees. Once the plans are deemed complete, a detailed review will begin on a “first-in, first-out” basis. If the submittal is not complete, notification will be given by OLWS to the Design Engineer specifying information needed.

Upon completion of the detailed review, OLWS will notify the Design Engineer, any revisions or “Red-line comments” OLWS may have. The Design Engineer will revise the plans, addressing all items in the OLWS letter, and return one electronic approved construction plan set to OLWS for approval.

## 1.1.6 As-Built Plan Requirements

For all Infrastructure facility improvements, the Design Engineer shall submit certified As-built drawings for all plans, which were approved for construction and a copy of the recorded plat. One set of As-built drawings shall be submitted for preliminary review. If the first submittal is not acceptable, the District Engineer will notify the Design Engineer of information needed for resubmittal.

As-built drawings and plat drawings shall meet the requirements of Subsections 1.1.2 (Plan Preparation), 1.1.3 (Required Streets), and 1.1.6 (As-Built Plan Requirements) and shall be of archival quality. At a minimum, one (1) hard copy shall be submitted and one (1) electronic copy shall be submitted in PDF file format and one (1) copy of drafting software such as .DWG shall be submitted.. As-built drawings shall include all field changes and be approved by OLWS. As-built drawings shall be created with a surveyed space of NAD83 projection.

The Design Engineer shall submit, along with the As-built drawings, a statement certifying that all work for which plans were approved has been completed in accordance with the OLWS Design and Construction Standard Specifications.

The words "as-built drawing" shall appear as the last entry in the revision block along with the month, day, and year the as-built drawing was prepared.

**NOTE:** Actual location and depth from finish grade of any other utilities encountered during construction shall be shown and noted on both plan and profile of the as-built plans.

### 1.1.6.01 Stormwater Drains

The following minimum information shall be noted on stormwater drain as-built drawings.

1. Station of wye or tee into main line. Tie end of branch line to nearest property corner at right-of-way line and distance back from the face of curb.
2. Alignment changes, grade changes, and changes in construction materials. If changed alignment results in station changes, a station equation shall be shown as appropriate at a manhole.
3. Other change altering the approved plans.
4. Other items as determined by OLWS.

### 1.1.6.02 Sanitary Sewer

The following minimum information shall be noted on sanitary sewer as-built drawings.

1. Station of wye or tee into main line. Stationing will reference Oak Lodge stations and be sequential on Oak Lodge numerical system. Tie end of service lateral to nearest property corner at right-of-way line and distance back from the face of curb.
2. Depth at the end of service lateral measured from existing ground to invert of pipe. When required by the District Engineer, invert elevations shall be noted.
3. Length of service lateral measured from centerline of sewer main to end of pipe.

4. Alignment changes, grade changes, and changes in construction materials. If changed alignment results in station changes, a station equation shall be shown as appropriate at a manhole.
5. Other changes altering the approved plans.
6. Provide complete test results to the District Engineer.
7. Type of pipe, backfill material and location.
8. All rim and invert elevations on manholes, catch basins, and clean outs.
9. Other items as determined by OLWS.

#### **1.1.6.03 Water Main**

The following minimum information shall be noted on water main as-built drawings.

1. Station and/or property line/corner to valves (not at standard location), all fittings, blow-offs, and dead-ended lines.
2. All changes from standard 36-inch depth cover. Limits shall be shown on plan with annotated reason for change. Actual pipe elevation (top of pipe) will be taken at every fitting.
3. Show alignment changes, grade changes, and changes in construction materials. If changed alignment results in station changes, a station equation shall be shown as appropriate at a valve.
4. Identify types of fittings (i.e., MJ x MJ, FLG x MJ, etc.); provide information in the form of an inventory list on construction drawings.
5. Other change altering the approved plans.
6. Provide design calculations and complete test results to the District Engineer.
7. Actual location and depth, from finish grade of street, of any other utilities encountered during construction.
8. Other items as determined by OLWS.

#### **1.1.7 Plan Quality and Miscellaneous Requirements**

All submitted items shall be in both hard copy as described in this Section and as electronic documents in PDF format. Plan sheets shall be collated into one single file. Multiple individual sheets will not be accepted. OLWS and other relevant details, notes and conditions shall be contained on the plan(s). Digital plans shall be vector-based, produced directly from drafting software such as AutoCAD. Scanned documents will be accepted only with prior approval and shall be at 360dpi minimum resolution.

If plans contain excessive linework, layers, have callouts that interfere with interpretation or are otherwise difficult to read, OLWS shall at its discretion, reject the plans. Any incomplete or rejected submittal shall count as a submittal for inclusion in the review fee order.

Each submittal shall contain responses to the relevant previous comments and/or conditions of approval as satisfied by the plans or submittal as a narrative in a “findings” format. The initial submittal narrative shall contain the land use decision conditions of approval with OLWS-related items responded to and successive submittals shall contain response(s) to the relevant comments from previous review(s).

Redlines are to be performed by the applicant or owner and shall be performed on all plan copies and shall be incorporated onto the final approved drawing set.

The applicant or owner coordinates with Clackamas County to establish a pre-construction meeting. The applicant shall coordinate with OLWS to attend this meeting. If OLWS is unable to do so, OLWS shall require an individual pre-construction meeting on-site or at the OLWS office.

Engineering review fees include one engineering review, one revision and plat review and as-built review for a partition or subdivision. Engineering review fees for design reviews with no plat include one review and one revision and one as-built review. Additional reviews are paid for with additional fees. Additional reviews are, for fee purposes, considered as new submittals and full review fees are charged.

### **1.1.8 Permit and Approval Vesting and Amendments**

All OLWS permits are valid for one year. Following expiration, a new permit shall be garnered by the owner and be subject to all relevant fees and/or regulations. Upon the date OLWS deems the application to OLWS to be complete, the application shall be vested with those current rules, regulations standards and other requirements being current at the date deemed complete. Other agency or jurisdictional approvals do not apply. The following are the vesting time ranges per OLWS permit. In the following the shortest time period applies if there are multiple permits referenced. Permit vesting shall consider section 1.1.8.01 Permit Amendments in this Chapter.

#### **1.1.8.01 Permit Amendments**

Should conditions or plans change from the original or approved conditions, the owner shall immediately apply for and obtain from OLWS an amendment to the permit prior to conducting any further work other than or different from that approved in the original permit. This includes submittal of updated permit application materials, and payment of amendment charges prior to the start of construction activities or other as determined by the General Manager. Permit amendments would not extend the vesting timeline.

#### **1.1.8.02 Permit Required**

A permit is required prior to work commencement. Failure to acquire permit(s) equates to a violation of the Rules and Regulations and Standards. An individual service connection permit and lateral shall be required for each individual house, dwelling, building or other structure or connection (physical or virtual) requiring sanitary sewage disposal. No installer shall install a sewer connection(s) in public right-of-way or public easements not covered by the OLWS issued permit. The issuance of a permit by OLWS will not relieve the permit holder from the responsibility of obtaining such other permits or licenses as may be required by other governmental agencies. Wastewater connections from multiple structures or dwellings within private property are regulated by the Clackamas County Building Division.

## **1.1.9 Disconnections**

### Sanitary Sewer

Property owners may voluntarily disconnect from the sanitary sewer system in the event that the building being served is being demolished<sup>2</sup>. Property owners may also voluntarily relocate where along the sanitary sewer mainline the building being served. Disconnections shall be capped at the main with a compression plug (Cherne) at the main and inspected by OLWS. Main lines may be required to be capped (plugged) at OLWS discretion.

### Drinking Water

Disconnections from the water system shall require the service to be severed on the meter side of the corporation stop with the corporation stop turned off and inspected by OLWS.

## **1.1.10 Replacement Service Lateral Installations**

If new service lateral alignment is proposed, the existing lateral shall be removed at main, plugged with a Cherne Plug, and inspected by OLWS prior to burial. The existing lateral shall be grouted at the downstream end.

If the existing lateral alignment is used, a new side sewer lateral shall be installed. The lateral shall conform to current OLWS standards and requirements. Replacing laterals may be performed by pipe bursting or trenching. If HDPE material is used from the main to the structure, Oak Lodge waives the cleanout construction requirement.

## **1.1.11 Building Sewer Repair**

OLWS's purview is the public sanitary sewer system. Only the Clackamas County Building Official shall permit and / or inspect sewer plumbing on private property (notwithstanding public easements).

## **1.1.12 Connection to Cesspools And Septic Tanks**

Direct connection from all plumbing fixtures in the structure(s) to the sanitary sewer system is required. Any connections to a cesspool, septic tank shall be removed and proper connection directly made to the public sewer system. Cesspools and septic tanks shall be abandoned in accordance with Clackamas County and Oregon Department of Environmental Quality requirements.

## **1.1.13 Sanitary Sewer Backflow**

OLWS reserves the right to require backwater valves to be installed on sanitary sewer laterals whenever conditions warrant at OLWS discretion. Typically, conditions involve flood-related locations or high-water tables.

---

<sup>2</sup> Pursuant to all relevant Oregon laws

### **1.1.14 Ownership and Acceptance And Bonding**

Performance Bond: See Rules and Regulations 8.58 and 10.8. This bond is separate from any other agencies bond such as Clackamas County. The owner shall submit a separate bond document to OLWS not combined with any other agencies.

Prior to commencement of construction, the owner shall submit a combined performance and warranty bond to OLWS. The bond or deposit shall be in the amount of 100% of all proposed sanitary, surface water (private) and public water work including installation costs. The performance bond shall automatically transform into a warranty bond upon completion of the improvement and the approval and acceptance thereof by OLWS. At that time, the applicant shall execute and deliver to OLWS a bill of sale or other document in form approved by OLWS transferring all right and title to the sewer main extension to OLWS, and a statement of value of the work completed. The warranty portion of the bond shall guarantee the associated infrastructure against any defects of labor and material for a period of one year from the date of acceptance by OLWS. Upon acceptance by OLWS of the infrastructure and the security for the one-year guarantee, the relevant infrastructure shall be incorporated in the OLWS system and be a part thereof and shall be maintained by OLWS, subject to the guarantee requirement for the first year.

### **1.1.15 Inspections and Authority**

Site Development / Engineering Review / Line Extension: OLWS inspects public main lines, side sewer laterals and all fittings, manholes, cleanouts and any other facility(ies) in the public right-of-way or easement. These utilities are installed by the owner. OLWS inspects the pipe zone within six inches surrounding the main line and / or side sewer lateral or other facilities including backfill, bedding, concrete and associated installation. Clackamas County generally inspects all other backfill and compaction and road surfaces.

Engineering Review / Stormwater facilities on private property (outside the public right-of-way): OLWS inspects any water quality facility including swales, rain gardens or other pollution control device such as mechanical filter. OLWS also inspects stormwater detention and/or retention facilities including swales, rain gardens or other pollution control device such as mechanical pipes.

Clackamas County inspects the following:

- all plumbing on private property for sanitary sewer and stormwater sewer and
- rain drains and stormwater infrastructure in the public right-of-way.

Utility Connection Permits / Sanitary Sewer: OLWS inspects public main lines, side sewer laterals and all fittings, manholes, cleanouts and any other facility(ies) in the public right-of-way or easement.

Utility Connection Permits / Water: OLWS inspects public main lines, services and all appurtenances and any other facility(ies) in the public right-of-way or easement. For water services of two inches and less, Oak Lodge installs the tap and corporation stop. The owner's contractor installs the water service pipe and appurtenances around the meter and Oak Lodge

inspects this installation. Finally, Oak Lodge inspects and installs the meter. For water services greater than two inches, the owner installs the entire service.

Erosion Prevention and Sediment Control: OLWS inspects all EPSC measures are installed prior to the start of any permitted activity. A pre-construction conference may be required when the risk of erosion is high due to one or more of the following factors:

- A. Construction during Wet Weather.
- B. Steep slopes with severe erosion potential.
- C. Construction adjacent to a sensitive area or vegetated corridor.
- D. Mass grading on a large site.

EPSC inspections of the site shall be ongoing by the Permittee or Applicant's authorized agent in accordance with approved plans to ensure compliance with the standards specified in this chapter. The Permittee or Applicant's authorized agent for inspections shall be knowledgeable in EPSC BMP selection, installation, and maintenance. They shall also possess the technical skills to assess conditions at the construction site that could impact stormwater quality, and to assess the effectiveness of EPSC BMPs selected. If the Permittee or representative determines the stormwater BMPs approved in the EPSC Plan are not effective or sufficient to ensure compliance, additional stormwater BMPs must be implemented and identified in a revised plan.

For single family developments that disturb 1 acre or greater and all non-single-family developments the Engineer's Inspector shall:

- A. Meet the applicable DEQ qualifying inspection certifications.
- B. Inspect the site once every 14 calendar days and within 24 hours of any storm event, including snowmelt, that results in discharge from the site.
- C. Maintain records of their EPSC inspection and maintenance activities. Records shall be made no later than 48 hours after inspection by the Permittee or their authorized agent. Records shall be made available to OLWS Inspector upon request.

For single family developments that disturb less than 1 acre, the Permittee's or representative shall:

- A. Inspect the EPSC measures and provide maintenance as required to maintain the functionality of the BMP measures.
- B. Inspect site daily when stormwater runoff, including runoff from snow melt, is occurring, once per week on active sites when runoff not occurring or once every two weeks on inactive sites
- C. Keep onsite documentation of their EPSC activities for reference during operations, maintenance activities, and inspections.

A final erosion control inspection shall be required on all sites after they have been stabilized and prior to approval of the Certificate of Occupancy. All temporary BMPs shall be removed prior to final inspection.

For single family sites seeking final erosion control inspection between September 1 and May 31, groundcover, using approved techniques, shall be completed before the single-family site can be deemed complete.

Design Review and Utility Connection Permits and Other Applicable / Erosion Prevention / Sediment Control: OLWS inspects all applicable sites and associated erosion prevention / sediment control and pollution control measures. These measures are installed by the owner.

#### **1.1.15.01 Inspection Request**

OLWS requires a twenty-four hour notice of inspection request which must be made online in each respective permit record. All relevant installations are to be inspected before their completion and while the installation and connections are still uncovered.

#### **1.1.15.02 Installation Without Inspection**

In the event an excavation is backfilled without an inspection first being completed by OLWS, then the owner shall cause the pipe to be exposed for the required inspection. All costs incurred in excavating a line for inspection shall be borne by the owner.

#### **1.1.15.03 Charges For Additional Inspections**

Excess Inspection Fee (see Fee Schedule) shall apply as follows:

- Where the pipe is laid and back-filled and/or connection of the building and/or side sewer made to the sanitary sewer system of OLWS without prior inspection and approval thereof by an inspector of OLWS, or the OLWS delegee.
- For each re-inspection and/or retesting of the pipe to be made because of the failure of the installer to comply with the ordinances, rules and regulations of OLWS and the Oregon State Plumbing Specialty Code and/or failure of the pipe to meet the minimum leakage requirements set by OLWS upon testing thereof.
- Should the owner wish an inspection outside of the regular working hours (7:30 am to 3:30 pm Monday through Friday) of OLWS, the applicant must apply to OLWS twenty-four hours in advance and make a deposit of triple the Excess Inspection Fee.

#### **1.1.16 Construction Quality**

If any work done under a permit granted by OLWS is not in accordance with the provisions of this code, and if the installer doing the work shall refuse to construct properly and complete such work, notice of such failure or refusal shall be given to the installer stating the nature of the violation and providing a reasonable time for corrections thereof. The installer shall, within the period of time stated in such notice, correct and complete the work. In the event the work is not so corrected and completed within the stated time, OLWS may cause said work to be completed if, in its opinion, the failure constitutes a hazard to safety or health, and the cost of such work and any materials necessary therefore shall be charged to the installer and shall be payable by the installer immediately upon notice and demand thereof given to the installer.

#### **1.1.17 Construction Duration**

All work within the limits of any public right-of-way shall be completed with due diligence. If any excavation is left open beyond a time reasonably necessary to complete the same, OLWS



may cause the excavation to be backfilled and the public right-of-way restored. Any costs of such work shall be charged to the property owner and shall be payable immediately to OLWS upon written notice and demand for the amount thereof given to the installer.

### **1.1.18 Damage**

Should any installer or person damage any portion of the system during repair, installation or any other activity, OLWS reserves the right to charge the property owner for reimbursement of all time, materials and resources allocated to the associated correction, inspection and assessment and any other related work.

### **1.1.19 DEQ Authority and Process**

The Oregon DEQ shall approve each sanitary sewer line extension in the OLWS service area. The Oregon DEQ reviews proposed sanitary sewer installation plans for every line extension and charges associated fees. For this review Clackamas County provides the Land Use Compatibility Statement. The Oregon DEQ shall be contacted by the applicant to submit the application and shall assure that the Oregon DEQ has provided OLWS the Sanitary Sewer Extension Approval.

### **1.1.20 Agency Coordination**

OLWS coordinates with CCDTD on land use development proposals within the County. The County has a policy to coordinate the review of development applications with OLWS, for proposals within OLWS jurisdiction, to ensure that approval is not granted in the absence of adequate utilities or a mechanism to provide them concurrently with development.

OLWS coordinates with the Clackamas County Department of Transportation and Development and Oregon Department of Environmental Quality on land use and/or development proposals within the County. In the Clackamas County Comprehensive Plan Chapter 11 Policy 1 of City, Special District and Agency Coordination's Policy 1 authorizes the County to: "Participate in interagency coordination efforts with federal, state, Metro, special purpose districts and cities. The County will maintain an updated list of federal, state and regional agencies, cities and special districts and will invite their participation in plan revisions, ordinance adoptions, and land use actions which affect their jurisdiction or policies."<sup>3</sup> The County has a policy to coordinate the review of development applications with OLWS, for proposals within OLWS's jurisdiction, to ensure that approval is not granted in the absence of adequate surfacewater management facilities per Clackamas County Zoning and Development Ordinance.

## **1.2 GENERAL CONSTRUCTION REQUIREMENTS**

---

### **1.2.1 Instructions to Bidders**

See Oak Lodge Water Services Purchasing Policies.

---

<sup>3</sup> <https://dochub.clackamas.us/documents/drupal/def278a5-a8a3-4883-94ba-20443d3ba068> May 23, 2018

## **1.2.2 Award and Execution of Contract**

See Oak Lodge Water Services Purchasing Policies.

## **1.2.3 Scope of Work**

### **1.2.3.01 Plans and Specifications**

The contract documents and/or conditions of approval will govern the work to be done. Anything mentioned in the Specifications and not shown on the Plans and detailed drawings or shown on the Plans and detailed drawings and not mentioned in the Specifications, shall be of like effect as though shown or mentioned in both. Specifications and Plans referred to in any of the contract documents and/or conditions of approval shall be considered as being included in the document in which such reference is made. When a particular standard plan or Specification is referred to, such reference shall be to the standard plan or Specification which is in force at the time of advertising for bids. The phrases, "Contractor shall", "Contractor will", etc. may not always be specifically stated in all paragraphs but is considered understood where not specifically stated otherwise.

### **1.2.3.02 Precedence of Contract Documents**

In case of conflict, the order of precedence of the following documents in controlling the work shall be:

1. Contract Change Orders
2. Special Provisions
3. Stamped Agency-prepared drawings specifically applicable to the Project and bearing the Project title
4. Permits from outside agencies required by law
5. Reviewed and accepted, stamped Working Drawings
6. Standard drawings and details
7. Approved unstamped working drawings
8. Supplemental Specifications
9. Standard/Technical Specifications
10. The Public Improvement Contract
11. All other Contract Documents not listed above

Notes on a drawing shall take precedence over drawing details.

Dimensions shown on the drawings, or that can be computed, shall take precedence over scaled dimensions.

### **1.2.3.03 Shop Drawings and Other Submittals**

Plans furnished and included with Specifications indicate the work proposed and the intended results.

By approving and submitting shop drawings, product data and samples, the Contractor represents that they have determined and verified all materials, field measurements, and field construction criteria related thereto, and that they have checked and coordinated the information contained within such submittals with the requirements of the work and of the contract documents and/or conditions of approval and that they have checked and coordinated the information contained within such submittals with the requirements of the work and of the contract documents and/or conditions of approval.

All required shop drawings, product data and samples shall be furnished to the District Engineer for their review and any required testing before any of the work or related work is performed or products or material ordered prior to the District Engineer's review and completion of any testing will be at Contractor's risk.

The District Engineer will review all shop drawings, product data and samples and conduct such tests as are required by the contract documents and/or conditions of approval within a reasonable time but in no event will the District Engineer be required to complete such review or conduct such tests in less than 14 days after submission. The District Engineer will notice the applicant stating one of the following:

1. Make corrections/additions noted: make the necessary changes and resubmit for review.
2. Set is ready for approval: send one digital set stamped by the Designing Engineer for construction.

The review by the District Engineer of any shop drawings, product data, samples, construction methods and equipment or other submittals is only for conformance with the general design concept of the project and does not extend to consideration of structural integrity, safety, detailed compliance with contract requirements, or any other obligation of the Contractor. Any action shown is subject to the requirements of the plans and specifications. The Contractor is responsible for confirming and correlating all dimensions; fabricating and construction techniques; coordinating their entire work in strict accordance with the contract documents and/or conditions of approval. The review does not relieve Contractor from their obligation fully to perform all Contract requirements, nor shall such review give rise to any right of action or suit in favor of Contractor or third persons, against OLWS.

#### **1.2.3.04 Changes in Work**

Without invalidating the agreement and without notice to a surety, OLWS may, at any time, order additions, deletions or revisions in the work: these will be authorized by a written amendment, a change order, or a work directive change.

Upon receipt of any such document, Contractor shall promptly proceed with the work involved that will be performed under the applicable conditions of the contract documents (except as otherwise specifically provided).

### **1.2.3.05 Force Account Work**

The Contractor shall perform work on a force account basis upon written notice by the District Engineer. If the District Engineer determines that the work increases the amount due under the Contract, payment will be made pursuant as force account work.

The Contractor must:

Maintain records in such a manner as to provide a clear distinction between direct cost of work performed on force account basis and costs of all other operations performed in connection with the Contract.

Daily, furnish to the District Engineer signed reports itemizing materials used and setting forth the cost of labor and charges for equipment rental, delineating whether said equipment is Contractor or Subcontractor owned. Provide names, identifications, and classifications of workmen, the hourly rate of pay and hours worked, and the size, type, and identification number of equipment and hours of equipment operation.

Substantiate material charges by vendor's invoices, submit such invoices with the reports; or, if not available, submit with subsequent reports. In the event said vendor's invoices are not submitted within 30 days after completion of the force account work owner reserves the right to establish the cost of such materials.

The District Engineer will compare their records with the reports furnished by the Contractor, make any necessary adjustments, compile the costs of work paid for on a force account basis and issue a change order covering the work.

### **1.2.3.06 Salvage**

When shown or specified, carefully salvage and stockpile within the construction area all castings, pipe and any discarded facilities, to be disposed of by owner.

## **1.2.4 Control of Work**

### **1.2.4.01 Authority of the District Engineer**

The District Engineer will decide all questions which may arise as to quantity, quality, and acceptability of materials furnished and work performed, the rate of progress of the work; interpretation of the Plans and Specifications; the measurement of all quantities; and the acceptable fulfillment of the Contract on the part of the Contractor. The District Engineer's estimates, decisions and approval signify favorable opinion and qualified consent; it does not carry with it certification or assurance of completeness, quality or accuracy concerning details. Such approval does not relieve Contractor from responsibility for errors, improper fabrication, improper construction methods, nonconformance to requirements or for deficiencies within their control.

It is further understood that all work to be done under the Contract will not be considered completed until it has passed final inspection by the District Engineer and is accepted by OLWS. It is further understood that the authority of the District Engineer is such that the Contractor shall at all times carry out and fulfill the instructions and directions of the District Engineer insofar as they concern the work to be done under the Contract.

The District Engineer shall have the authority to order unacceptable work to be corrected, removed or replaced, and unauthorized work to be removed and, pending completion of such order, to deduct the estimated cost thereof from any monies due, or to become due the Contractor including retainage. This authority shall take precedence over any and all requirements of the specifications for payment set forth elsewhere in the specifications.

At the District Engineer's sole discretion, minor defects in the work may be accepted subject to a reasonable deduction from the Contract price or other credits to the owner. Such determination by the District Engineer shall be final.

The District Engineer is not authorized to waive any written notice required of the Contractor by the Contract.

#### **1.2.4.02 Authority and Duty of Inspectors**

The District Engineer may appoint assistants to inspect all materials used and all work done. Such inspection may extend to any or all parts of the work and to the preparation or manufacture of materials to be used. Inspectors will not be authorized to revoke, alter, enlarge, or relax the provisions of the Contract. An Inspector is placed on the work to keep the District Engineer informed of progress of the work and the manner in which it is being done. In addition, the Inspector shall call to the attention of Contractor any deviation from the Plans, or Specifications.

An Inspector will not be authorized to approve or accept any portion of the work or to issue instructions contrary to the Plans and Specifications under this Contract. Furthermore, the Inspector is not authorized to waive any written notices required by the Contract. The Inspector will have authority to reject defective material and to suspend any work that is being improperly done, subject to final decision by the District Engineer.

#### **1.2.4.03 Responsibility of Contractor**

Do all work and furnish all labor, materials, equipment, tools, and machines necessary for the performance and completion of the project in accordance with the Contract. Be obligated to determine and be responsible for the method of construction.

Contractor shall be solely liable for any accident, loss or damage happening to work referred to in the Contract prior to completion and acceptance thereof.

Contractor shall be responsible for coordinating and scheduling work with residents and property owners, local garbage service, and US Postal Service within and adjacent to the Project.

#### **1.2.4.04 Notification of Utilities and Agencies**

Obtain prior approval from Clackamas County for closing or partial closing of any street. When performing work in streets and easements, whether inside or outside OLWS's legal boundaries, notify all of the affected utilities and local agencies about the operations so as to properly coordinate and expedite the work in such a manner as to cause the least amount of conflict and interference between the operations and those of other agencies.

The Contractor and its Subcontractors must comply with all provisions of OAR 952-001-0050 including notification of all owners of underground facilities at least 48 business day hours but not more than 10 business days before beginning work. Notify the following utilities and agencies in writing at least 2 working days before commencing any work on the project.

1. OLWS Technical Services Department
2. Northwest Natural Gas Co.
3. Oregon Department of Transportation
4. Portland General Electric Co.
5. Comcast
6. Century Link
7. Water Environment Services of Clackamas County

Other applicable municipalities, agencies or special districts or providers

OLWS shall relocate or cause to be relocated all privately or publicly owned utility conduits, lines, poles, mains, pipes, and such other facilities within the jurisdiction and control of OLWS where such relocation is necessary in order to conform said utility and other facilities with the plans and ultimate requirements of the project. If desirable for specific reasons, or for convenience of field operations, contact the above listed utilities.

#### **1.2.4.05 Utilities and Existing Improvements**

Information shown as to location of existing water courses, drains, sewer lines, or utility lines is provided for Contractor's information and convenience and is not, in any way, warranted to be accurate by OLWS. Contractor shall verify all such information and shall deal with varying conditions at its own expense.

Operation of water valves and hydrants by unauthorized personnel is strictly prohibited. Obtain written permission from and pay any fee required from OLWS prior to using hydrant water.

Provide for the flow of sewers, drains, or water courses interrupted during the progress of the work, and restore such drains or water courses as approved by the District Engineer, at no additional cost to OLWS.

Be responsible for all costs for the repair of any and all damage to any utility, whether previously known or disclosed during the work, as may be caused by the work. Maintain in place utilities not shown on the drawings to be relocated or altered by others. If Contractor requires temporary relocation, for their convenience or because of their method of construction or as a result of site conditions, Contractor shall bear all costs for said temporary relocation. Maintain utilities which have been relocated by others in their relocated positions in order to avoid interference with structures which cross the project work.

Make excavations and borings ahead of work, as necessary, to determine the exact location of interfering utilities or underground structures. When this is not feasible or practical or the need for such work was not foreseen, the utility owners or OLWS shall have the right to enter upon the right-of-way and upon any structure therein for the purpose of making new installations, changes or repairs. Conduct operations so as to provide the time needed for such work to be accomplished during the progress of the improvement, at no additional cost to the owner.

It is understood that there will be interfering utilities, service laterals, and other underground pipes, drains or structures encountered on underground projects that are not shown or are shown incorrectly on the plans and/or have not been previously discovered in the field. Contractor agrees this is a normal and usual occurrence in the construction of underground improvements. Furthermore, bidders understand and agree that work in some cases must be done in close proximity to said utilities and underground pipes, drains, and structures not shown or shown incorrectly on the plans which may require a change in operations and may cause sloughing of the trench, additional traffic control, additional pavement and backfill costs, and time; the Contractor agrees that a reasonable number of these occurrences are usual and ordinary on underground projects and are reflected in the bid and plan of operation.

The District Engineer will require a reasonable amount of time to perform design changes necessitated by directly conflicting utilities and/or the utility owners will require a reasonable amount of time to make necessary utility relocations.

The Bidders agree to provide for these conflicts and interferences and agree to provide for a reasonable amount of time for design changes and/or utility relocations due to said interference in the bid and understand that no additional compensation for interruption of schedule, extended overhead, delay or any other impact claim or ripple effect or any other costs whatsoever or additional time will be made for these conflicts or interferences.

#### **1.2.4.06 Survey Service**

Give notice to the District Engineer not less than 3 working days in advance of when survey services will be required in connection with the laying out of any portion of the work.

The District Engineer will furnish appropriate offset lines and grades as they deem necessary for all projects involving trenching operations. Contractor will be responsible for the transfer of the offset lines or grades into the ditch, to batter boards, or any other point within the work. Work done without lines and grades having been established by the District Engineer or work done beyond the lines and grades will be considered as unauthorized and will not be paid for and may be ordered removed, replaced, or corrected at no expense to OLWS.

#### **1.2.4.07 Protection of Survey Markers**

##### **1.2.4.07.01 Permanent Survey Markers**

Notify the District Engineer not less than three working days prior to starting work in order that the District Engineer may take necessary measures to ensure the preservation of survey monuments, stakes, lot stakes, and benchmarks. Do not disturb permanent survey monuments, stakes, lot stakes, or benchmarks without the consent of the District Engineer and notify the District Engineer and bear the expense of replacing any that may be disturbed.

When a change is made in the finished elevation of the pavement of any roadway in which a permanent survey monument is located, preserve the monument, and adjust the monument cover to the new grade at no expense OLWS.

##### **1.2.4.07.02 Construction and Survey Markers**

Preserve construction survey stakes and marks for the duration of their usefulness during construction. If any construction survey stakes are lost or disturbed through negligence of Contractor, and in the judgment of the District Engineer need to be replaced, such replacement shall be by the District Engineer at the expense of Contractor. The cost of replacement shall be charged against and shall be deducted from payments for Contract work.

#### **1.2.4.08 Protection of Property**

Protect all public and private property, insofar as it may be endangered by operations and take every reasonable precaution to avoid damage to such property.

Restore and bear the cost of any public or private improvement, facility, structure, or land and landscaping within the right-of-way or easement which is damaged or injured directly or indirectly by or on account of an act, omission, or neglect in the execution of the work. Restore to a condition substantially equivalent to that existing before such damage or injury occurred, by repairing, rebuilding, or otherwise effecting restoration



thereof, or if this is not feasible, make a suitable settlement with OLWS of the damaged property.

Give reasonable notice to occupants of buildings on property adjacent to the work to permit the occupants to remove vehicles, trailers and other possessions as well as salvage or relocate plants, trees, fences, sprinkler systems, or other improvements in the right-of-way which are designated for removal or which might be destroyed or damaged by work operations.

Protect all designated trees, lawns and planted areas within the right-of-way or easements. Restore all on-surface disturbed areas, by methods as set forth in the technical specifications. If conditions are such that the method specified cannot be done, provide erosion control surface covering of such quality and quantity as will prevent erosion from occurring, without adverse impacts to the environment, if required by conditions existing at the site, at no additional cost to OLWS.

Review with the District Engineer the location, limits and methods to be used prior to clearing work. Clearing and grubbing shall be performed in strict compliance with all local, State and federal laws and requirements pertaining to clearing and burning, and particularly in conformity with the provisions of ORS Chapter 477, and all subsequent amendments, which require, among other things, filing with the State Forester a general description of the right-of-way to be cleared before the start of clearing operations. Obtain the required permit from the State Forester and OLWS and perform clearing work in conformance thereto.

#### **1.2.4.09 Use of Work During Construction**

OLWS shall have the right to take possession of and use any completed or partially completed portions of the work. Such use shall not be considered as final acceptance of the work or portions thereof.

Such action by OLWS will not relieve the Contractor of responsibility for injury or damage to said completed portions of the work resulting from use by public traffic, action of the elements, Contractor's operations, defective work, or negligence, or from any other cause, except for injury or damage resulting from OLWS's negligence. Contractor will not be required to again clean up such portions of the work prior to final acceptance, excepting for such clean up as results from Contractor's operations or defective work. Use of any completed or partially completed portions of the work does not relieve Contractor from the warranty responsibility nor shall the warranty period commence to run until final completion and acceptance of the work.

#### **1.2.4.10 Furnishing Temporary Services and Facilities**

Install, furnish and maintain temporary light, power, water and any temporary services or facilities complete with connecting piping, wiring, lamps, and similar equipment during construction of the work, including testing and start up. Remove temporary facilities upon completion of work. Obtain all permits and bear all costs in connection

with temporary services and facilities. Conform to applicable statutes, rules, codes, and other requirements in the use of these facilities.

#### **1.2.4.11 Verbal Agreements or Representations**

No verbal agreement or conversation by or with any officer, agent or employee of OLWS, either before or after execution of the Contract, shall affect or modify any of the terms or obligations contained in any of the documents comprising the Contract. Any such verbal agreement or conversation is in no way binding upon OLWS.

#### **1.2.4.12 Water and Air Pollution Control**

During the term of the Contract, Contractor's operations shall conform to applicable laws and regulations of the Oregon DEQ, and other agencies of the State and Federal Government, OLWS Erosion Control Plans, as well as other local ordinances and resolutions designed to prevent, control, and abate water and air pollution.

During all phases of the work, or when directed, protect work sites, storage and disposal areas from washout and erosion, and take precautions to control or abate dust nuisance and air pollution by cleaning up, sweeping, sprinkling, covering, enclosing, or sheltering work areas, and stockpiles, and by promptly removing from paved streets earth or other material which may become airborne or may be washed into waterways or drainage systems.

#### **1.2.4.13 Noise**

Conform and comply with applicable noise regulations as established in the Clackamas County Code. Work hours are restricted to the hours of 7:00 a.m. to 7:00 p.m. during the weekdays and 8:00 a.m. to 5:00 p.m. on the Saturday.

#### **1.2.4.14 Access to the Work**

Provide access to the work for representatives of OLWS, the State of Oregon, the Federal Government, and other entities having jurisdiction in the area.

Allow access to the District Engineer or their representatives to all parts of the work and to plants of manufacturers at all times.

#### **1.2.4.15 Defective or Unauthorized Work**

All work which does not conform to the requirements of the Contract shall be considered as unacceptable.

Upon discovery immediately remove unacceptable and defective work and replace by work and materials which conform to the Contract. This provision shall have full effect regardless of the fact that the unacceptable work may have been done or the defective materials used with the full knowledge of the Inspector.

## **1.2.5 Control of Materials**

### **1.2.5.01 Preference for Use of Oregon Products**

Preference may be given to services, articles or materials produced or manufactured in Oregon, if price, fitness, availability and quality are otherwise equal. These provisions do not apply to Contracts on projects financed wholly or in part by federal funds.

### **1.2.5.02 Quality of Work**

Materials, parts, products and equipment which are to be incorporated into the work shall be new and shall conform to the contract documents.

### **1.2.5.03 Sampling and Testing**

Tests of the work may be made by OLWS at any time during construction of the work or during the production, fabrication, or preparation and use of materials, parts, products, and equipment.

OLWS reserves the right to require samples and to test products for compliance with pertinent requirements irrespective of prior certification of the products by the manufacturer.

When such tests of the work are necessary, as determined by the District Engineer, such tests will be made by and at the expense of OLWS unless otherwise specified. Provide such facilities and cooperate as required for collecting and forwarding samples and do not incorporate into the work until tests have been made and found acceptable. In all cases furnish the required samples without charge and in ample time to permit testing prior to use. Provide safety measures and devices to protect those who take the samples.

In the absence of any reference Specification, it shall be understood that materials shall meet the Specifications and requirements of ASTM, as directed by the District Engineer. When there is no pertinent coverage under ASTM, the material concerned shall meet Specifications and requirements of applicable commercial standards of the Commodity Standards Division of the U.S. Department of Commerce. Lacking such coverage, materials shall meet requirements established by reputable industry for a high-quality product of the kind involved.

All testing shall be performed by the testing laboratory, the District Engineer, or as directed by the District Engineer.

In the event the District Engineer requests tests and the work fails, the Contractor shall bear all costs for this test and all subsequent testing necessary to meet specified requirements.

#### **1.2.5.04 Certification**

The District Engineer may, at their sole discretion and in lieu of any other required sampling and testing, accept from Contractor two copies of the manufacturer's certification with respect to the product involved, under conditions set forth as follows:

1. Certification shall state that the named product conforms to OLWS requirements and that representative samples thereof have been sampled and tested as specified.
2. Certification shall either be accompanied by a certified copy of test results or certify that such test results are on file with the manufacturer and will be furnished to the District Engineer upon request.
3. Certification shall give the name and address of the manufacturer and the testing agency and the date of tests; and shall set forth the means of identification which will permit field determination of the product delivered to the project as being the product covered by the certification.
4. Contractor shall be responsible for any costs of certification or for any costs of the sampling and testing of products in connection therewith.

#### **1.2.5.05 Inspection by Others**

Inspection of work by persons other than representatives of OLWS will not constitute inspection by OLWS.

#### **1.2.5.06 Storage and Protection of Items of Work**

Store items to be incorporated into the work to assure the preservation of their quality and fitness for the work. Stored items, even though approved before storage, may be re-inspected and are subject to rejection prior to being incorporated into the work. Stored items shall be located so as to facilitate their prompt inspection.

#### **1.2.5.07 Trade Names, Equals, or Substitutions**

In order to establish a basis of quality, certain processes, types of machinery or equipment, or kinds of materials may be specified—either by description of process, by designating a manufacturer by name and referring to their brand or product designation, or by specifying a kind of material. It is not the intent of these specifications to exclude other processes, equipment, or materials of equal value, utility, or merit.

Whenever a process is designated; a manufacturer's name, brand, or item designation is given; or a process or material covered by patent is designated or described; it shall be understood that the words "or equal" follow such name, designation, or description, whether in fact they do so or not. This "or equal" clause is not a warranty, either expressed or implied, by OLWS that an equal exists.

The Contractor may offer to furnish materials or equipment of equal or better quality and performance than that specified as a substitute after the Contract is executed. If the

offer necessitates changes to, or coordination with, any other portion of the work, the data submitted shall include drawings and details showing all such changes. Contractor agrees to perform these changes as part of the substitution of material or equipment. Acceptance by the District Engineer shall not relieve the Contractor from full responsibility for the efficiency, sufficiency, quality, and performance of the substituted material or equipment in the same manner and degree as the material and equipment specified by name. Any cost differential associated with a substitution shall be reflected in the Contract price and the Contract shall be appropriately modified by change order.

If the bid includes a list of equipment, materials, or articles for which Contractor must name the manufacturer at time of submission of the bid, no substitutions therefore will be permitted.

All materials or equipment of equal or better quality offered by the Contractor for substituting shall be approved by the District Engineer prior to incorporation into the project.

## **1.2.6 Legal Relations and Responsibilities**

### **1.2.6.01 Laws and Regulations**

Comply with all federal and State laws; all local laws, ordinances, and regulations; and all orders and decrees of bodies or tribunals having any jurisdiction or authority, which in any manner affect those engaged or employed on the work, or which in any way affect the conduct of work. Observe and comply with all such laws, ordinances, regulations, orders, and decrees. Protect and indemnify OLWS and their representatives against any claim or liability arising from, or based on, the violation of any such law, ordinance, regulation, order, or decree—whether by Contractor, their Subcontractors, suppliers of materials or services, or others engaged by the Contractor or their employees.

In addition to those set forth herein, the OLWS Public Contracting rules and the Statutes of the State of Oregon for public works contracts, ORS Chapters 279A and 279C, are incorporated by reference into the Contract.

### **1.2.6.02 Subcontractors**

After Contract award and notice of Contractor/Subcontractor agreements have been submitted, work shall not be transferred or subcontracted without prior consent of OLWS.

Use of Subcontractors, material suppliers or equipment suppliers shall in no way release Contractor from any obligations of contract with OLWS.

Contractor will provide in all subcontract agreements that the Subcontractor, material supplier and equipment supplier will be bound by the terms and conditions of this Contract to the extent that they relate to the Subcontractor's work, material or equipment. All Subcontractor's agreements will also provide that they are assignable to

OLWS at OLWS's option, in the event this agreement is terminated for default of Contractor.

#### **1.2.6.03 No Waiver of Legal Rights**

OLWS shall not be precluded by any measurement, estimate or certificate made either before or after completion and acceptance of work or payment therefore, from showing the true amount and character of work performed and materials furnished by the Contractor, or from showing that any such measurement, estimate or certificate is untrue or incorrectly made, or that work or materials do not conform in fact to the Contract. OLWS shall not be precluded, notwithstanding any such measurement, estimate or certificate, or payment in accordance therewith, from recovering from the Contractor and their sureties such damages as it may sustain by reason of their failure to comply with terms of the Contract, or from enforcing compliance with the Contract. Neither acceptance by OLWS, or by any representative or agent of OLWS, of the whole or any part of the work, nor any extension of time, nor any possession taken by OLWS, nor any payment for all or any part of the project, shall operate as a waiver of any portion of the Contract or of any power herein reserved, or any right to damages herein provided. A waiver of any breach of the Contract shall not be held to be a waiver of any other breach.

#### **1.2.6.04 Other Contracts**

OLWS reserves the right to award other contracts or issue permits for work that may require coordination with the work to be performed under this Contract.

When separate contracts or permits are awarded or issued for different portions of the Project, "the Contractor" in the contract documents in each case shall be the Contractor who signs each separate contract.

**Mutual Responsibility of Contractors:** The Contractor shall afford other Contractors reasonable opportunity for the introduction and storage of their materials and equipment and the execution of their work, and shall properly connect and coordinate their work with theirs.

If any part of the Contractor's work depends for proper execution or results upon the work of any other separate Contractor, the Contractor shall inspect and promptly report to the District Engineer any apparent discrepancies or defects in such work that render it unsuitable for such proper execution and results. Failure of the Contractor to inspect and report shall constitute an acceptance of the other Contractor's work as fit proper to receive the work, except as to defects which may develop in the other separate Contractor's work after the execution of the Contractor's work.

Should the Contractor cause damage to the work or property of any separate Contractor which results in a claim against OLWS, and if the claim is not satisfied by Contractor and the separate Contractor sues OLWS or initiates an arbitration proceeding on account of any damage alleged to have been so sustained, OLWS shall notify the Contractor who shall defend if requested such proceedings at the Contractor's expense, and if any

judgment or award against OLWS arises therefrom the Contractor shall pay or satisfy it and shall reimburse OLWS for all attorney's fees and court or arbitration costs which OLWS has incurred.

The Contractor shall be responsible for any cutting, fitting and patching that may be required to complete the work except as otherwise specifically provided in the Contract. The Contractor shall not endanger any work of any other Contractors by cutting, excavating or otherwise altering any work and shall not cut or alter the work of any other Contractor. Any costs caused by defective or ill-timed work shall be borne by the party responsible, therefore.

If a dispute arises between the separate Contractors as to their responsibility for cleaning up, OLWS may clean up and charge the cost thereof to the several Contractors as the District Engineer shall determine to be just.

#### **1.2.6.05 Liability and Indemnification**

The Contractor shall assume all responsibility for the work and shall bear all losses and damages directly or indirectly resulting to the Contractor, to OLWS, to the District Engineer, and to their officers, agents, and employees on account of (a) the character or performance of the work, (b) unforeseen difficulties, (c) accidents, or (d) any other cause whatsoever.

The Contractor shall defend, indemnify, and hold harmless OLWS, the Design Engineer, and their officers, agents and employees from all claims, loss, damage, and injury of every kind directly or indirectly arising out of this Contract. The Contractor shall assume this responsibility even if (a) fault is the basis of the claim, and (b) any act, omission or conduct of OLWS connected with the Contract is a condition or contributory cause of the claim, loss, damage or injury.

The Contractor shall not be liable for, nor be required to defend, or indemnify OLWS or the Design Engineer relative to any claim, loss, damage, or injury resulting solely from acts or omissions by OLWS, the Design Engineer, or their officers, agents or employees. The Contractor shall not be liable for, nor be required to defend, or indemnify OLWS or the Design Engineer relating to any claim loss, damage, or injury arising from the use of any maps, drawings, reports, surveys, designs, or specifications furnished by OLWS, Design Engineer, or their officers, agents, or employees.

Any specific duty or liability imposed or assumed by the Contractor, as may be otherwise set forth in the contract documents, shall not be construed as a limitation or restriction of the general liability or duty imposed upon the Contractor by this section.

The Contractor shall assume all responsibility for the work.

#### **1.2.6.06 Insurance**

##### **1.2.6.06.01 General**

The Contractor shall provide and maintain during the life of this Contract the insurance coverage designated hereafter. All costs for such insurance shall be borne by the Contractor and shall be included in the Contract price.

Prior to execution by OLWS and before commencing work under this Contract, Contractor shall furnish the District Engineer with certificates of insurance specified herein showing the name of the insurance carrier, coverage, type, amount (or limits), policy numbers, effective and expiration dates, description of operations covered, and containing substantially the following cancellation provision:

"The insurance covered by this certificate will not be canceled or materially reduced, except after 30 days written notice has been received by OLWS."

In case of the breach of any provision of this Article, OLWS, at its option, may take out and maintain, at the expense of the Contractor, such insurance as OLWS may deem proper. OLWS may deduct the cost of such insurance from any monies which may be due or become due the Contractor under this Contract.

#### **1.2.6.06.02 Review and Approval of Insurance**

The Contractor shall not commence work under this Contract nor allow any Subcontractor to commence work on a subcontract until the Contractor has obtained all the insurance required hereunder and such insurance has been approved by the Attorney. All policies or insurance and certificates of insurance shall be satisfactory to OLWS. Approval of the insurance shall not relieve or decrease the liability of the Contractor hereunder.

#### **1.2.6.06.03 Workers' Compensation, the Federal Longshoremens' and Harborworkers' Act, and the Federal Jones Act**

The Contractor shall provide and shall require all Subcontractors to provide workers' compensation coverage for all persons employed under this Contract including the Contractors' partners and any individual regardless of relation to the Contractor's partners and any individual regardless of relation to the Contractor or to the partners who provide work under this Contract. The Contractor shall be required to assure that subject workers will receive the compensation for compensable injuries provided in ORS Chapter 656 either by:

1. a carrier-insured employer; or
2. a self-insured employer as provided by ORS 656.407.

In addition to the statutory benefits outlined above, the Contractor and all Subcontractors shall provide employers' liability insurance with limits of not less than:

1. \$2,000,000 each occurrence
2. \$2,000,000 disease each employee
3. \$2,000,000 disease—policy



Evidence of such coverage, including the guaranty or warrant period, shall be filed with OLWS and maintained for the duration of the Contract.

The Contractor shall defend, indemnify, and hold harmless, OLWS and the OLWS's officers, agents, and employees against any liability that may be imposed upon them by reason of the Contractor's or Subcontractor's failure to provide workers' compensation and employers liability coverage.

**1.2.6.06.04 General Liability and Automobile Liability**

The Contractor shall provide a general liability policy that provides coverage for bodily injury including personal injury and property damage liability insurance and automobile liability insurance. Such insurance must protect the Contractor, OLWS, and their officers and employees from all things or damage which may arise out of this Contract or in connection therewith, including all operations of Subcontractors. Such insurance shall provide coverage for not less than the amounts for which public bodies are responsible as set forth in ORS Chapter 30.260 - 30.300, Tort Actions against public bodies, but in no event less than the following limits of liability:

The policy shall contain an endorsement that the aggregate applies separately to this Contract.

**Commercial General Liability Insurance**

1. \$2,000,000 each occurrence limit
2. \$3,000,000 general aggregate
3. \$3,000,000 products/completed operations aggregate
4. \$3,000,000 personal and advertising injury
5. \$2,000,000 limited job site pollution occurrence sub-limit

**Comprehensive Automobile Liability Insurance Including Coverage for all Owned, Hired, And Non-owned Vehicles.**

1. \$2,000,000 each occurrence combined single limit
2. \$3,000,000 aggregate bodily injury and property damage, or \$2,000,000 each person bodily injury
3. \$2,000,000 each occurrence bodily injury
4. \$2,000,000 each occurrence property damage
5. \$2,000,000 each occurrence pollution occurrence sub-limit

The insurance shall be written on a comprehensive form which includes broad form property damage on an occurrence basis. Unless excluded by Special Specification, the general liability policy shall include, without deductible, coverage for premises operations, explosion and collapse hazard, underground hazard, products, completed operations, contractual insurance, and independent Contractors. Such insurance shall be maintained until the expiration of the guaranty period required by the Contract. Failure to maintain liability insurance

as provided above shall, at OLWS's option, because for immediate termination of the Contract.

The Contractor shall provide a letter from the insurance company which states that such insurance shall be without prejudice to coverage otherwise existing.

OLWS, its officers, agents, and employees, shall be named additional insureds in the Contractor's General Liability Insurance policy.

The policy shall also provide for a Cross Liability Endorsement or Separation of Insureds Endorsement.

The policy shall be endorsed to provide an Amendment - Aggregate Limits of Insurance (per project) specifying that a separate aggregate limit of liability applies to this Contract.

If there are insufficient insurance proceeds and assets of the Contractor to fully indemnify OLWS, its officers, employees, agents, and the District Engineer, then OLWS, its officers, employees, and agents would be indemnified first with any remaining insurance proceeds and assets to be used to indemnify the District Engineer.

If set forth in the Special Specifications, additional insureds may be the District Engineer, other governmental bodies with jurisdiction in the area involved in the project, and their officers and employees and such agents as may be specified.

#### **1.2.6.06.05 Claims on Project**

The Contractor, when notified of a claim by an affected party shall:

1. Refer claim to the Contractor's insurance carrier or claims administrator.
2. Contractor's insurer will copy OLWS on acknowledgment of claim.
3. Contractor's insurer will copy OLWS on notice to claimant of disposition of claim.

#### **1.2.6.06.06 Builders Risk Insurance**

During construction, Contractor shall obtain and maintain for the benefit of the parties to the Contract as their interest may appear, all-risk builder's risk insurance to the extent of 100% of the value of the project. Coverage shall also include: (1) formwork in place; (2) form lumber on site; (3) temporary structures; (4) equipment; and (5) supplies related to the work while at the site. Such insurance shall be endorsed to require 30 days' written notice to OLWS prior to cancellation or change of the policy. One (1) copy of the policy and 2 certificates of such insurance shall be delivered to OLWS before commencing work and shall be subject to review and approval by OLWS. OLWS may temporarily waive delivery of the copy of the policy. In the event Contractor fails to maintain such insurance, OLWS may arrange therefore; and any premium incurred shall be to the account of Contractor.

#### **1.2.6.06.07 Insurance for Work in Railroad Rights-of-Way**

During construction in railroad right-of-way, Contractor shall obtain and maintain insurance as required by the individual railroads.

#### **1.2.6.07 Royalties and Patents**

Contractor shall pay all royalties and license fees required to perform the work. Defend and indemnify OLWS from all loss or damage that may result from the Contractor's wrongful or unauthorized use of any patented article or process.

#### **1.2.6.08 Permits**

Contractor shall obtain all Municipal, County, State, federal, or other permits or licenses necessary or incident to performance of the work under this Contract. Work within the railroad right-of-way requires permit by the rail authority and railroad operators in addition to the above. Comply with all permit requirements pertaining to the project.

#### **1.2.6.09 Compliance with ORS Chapter 279A, B, and C (Public Contracting Code)**

Comply, and require all Subcontractors to comply, with the OLWS's Public Contracting Rules, the requirements of the applicable State statutes, and be subject to the applicable liabilities provided in ORS Chapter 279A, B and C, such as, but not limited to, the statutes that are numbered and referenced, and incorporated herein by an abbreviated subject matter, and listed below and the statutes required to be set forth as conditions in public contracts, which follows.

1. ORS 279C.375 Award of contract; Bond; Waiver of bond in case of emergency.
2. ORS 279C.505 Drug Testing Program
3. ORS 279C.540 Maximum hours of labor on public contracts; holidays; exceptions.
4. ORS 279C.840 Workers on public works to be paid not less than prevailing rate of wage.
5. ORS 279C.845 Certification of rate of wage by Contractor or Subcontractor.
6. ORS 279C.850 Inspection to determine whether prevailing rate of wage being paid; proceedings to require payment of prevailing rate of overtime.
7. ORS 279C.855 Liability of Violations.

#### **1.2.6.10 Labor**

Upon notification in writing from the District Engineer, remove immediately from the job for its duration any laborer, workman, mechanic, foreman, superintendent, or other person employed who is found to be incompetent, intemperate, troublesome, disorderly or otherwise objectionable, or who fails or refuses to perform their work properly or acceptably.

Comply with provisions of the OLWS's Equal Opportunity Policy and to ORS Chapter 659 relative to unlawful employment practices and discrimination by employers against any employee or applicant for employment because of race, religion, color, sex, or national origin. Particular reference is made to ORS 659.030, which states that it is unlawful employment practice for any employer, because of the race, religion, color, sex, or national origin of any individual, to refuse to hire or employ or to bar or discharge from employment such individual or to discriminate against such individual in compensation or in terms, conditions or privileges of employment.

#### **1.2.6.11 Overtime**

Contractor shall notify the District Engineer of any overtime operations as soon as possible. The Contractor must provide documentation to the District Engineer's satisfaction justifying the overtime work (ORS 279C.520).

In the event that the Contractor wishes to proceed with an overtime operation, the Contractor must first notify and obtain approval from the District Engineer to do so, prior to commencing such work.

For overtime work requested by the Contractor, the Contractor shall pay the applicable wage rate for the District Engineer's Inspector, engineering and operations personnel, and other staff required at the project during the overtime hours.

This section does not apply to labor performed in the manufacture or fabrication of any material ordered by the Contractor or manufactured or fabricated in any plant or place other than the place where the main Contract is to be performed.

#### **1.2.6.12 Safety**

##### **1.2.6.12.01 Employee Safety**

The Contractor shall at all times be responsible for the safety of their employees and their Subcontractor's employees. The Contractor shall maintain the job site and perform the work in a manner which meets OLWS's responsibility under statutory and common law for the provision of a safe place to work and which complies with OLWS's written safety regulations, if any.

Conduct the project with proper regard for the safety and convenience of the public. When the project involves use of public ways, provide necessary flag persons and install and maintain means of reasonable access to all fire hydrants, service stations, warehouses, stores, houses, garages, and other property. Private residential driveways shall be closed only with approval of the District Engineer or specific permission of the property owner. Do not interfere with normal operation of public transit vehicles unless otherwise authorized. Do not obstruct or interfere with travel over any public street or sidewalk without approval. At all times provide open trenches and excavations with secured and adequate barricades or fences of an approved type which can be seen from a reasonable distance. Close up or plate all open excavations at the end of each

working day in all street areas unless approved otherwise by the District Engineer and in all other areas when it is reasonably required for public safety or as directed by the District Engineer. At night, mark all open work and obstructions by lights. Install and maintain all necessary signs, lights, flares, barricades, railings, runways, stairs, bridges, and facilities. Observe all safety instructions received from the District Engineer or governmental authorities, but following of such instructions shall not relieve Contractor from its responsibility or liability for accidents to workmen or damage or injury to person or property.

#### **1.2.6.12.02 Public Safety and Convenience**

The Contractor shall at all times conduct their work so as to ensure the least possible obstruction to traffic and convenience to the general public and residents in the vicinity of the work and to ensure the protection of persons and property. No road or street shall be closed to the public except with the permission of the District Engineer and proper governmental authority. Fire hydrants on or adjacent to the work shall be kept accessible to firefighting equipment at all times. Temporary provisions shall be made by the Contractor to ensure the use of sidewalks, private and public driveways and proper functioning of all gutters, sewer inlets, drainage ditches and culverts, irrigation ditches and natural water courses. The Contractor will minimize inconvenience to others due to mud and dust.

#### **1.2.6.12.03 Safety Program**

The Contractor shall adopt a written safety program complying with the requirements of employee and public safety set forth hereinabove and as described in the Special Conditions. The safety program shall also comply with OAR Chapter 437, Division 3, regarding general safety and health provisions.

#### **1.2.6.13 Right-Of-Way, Easements and Premises**

Confine construction activities within property lines, right-of-way, limits of easements and limits of construction permits as shown or specified in the contract documents unless arrangements are made with owner(s) of adjacent private property. If additional space or property is needed to accommodate Contractor's method for construction of the work or for the convenience of the Contractor, Contractor shall bear all related costs and responsibilities. Prior to the use of any private property outside the specified boundaries, file with the District Engineer written permission from the property owner(s).

Do not unreasonably encumber the specified work areas with materials and equipment. Obtain and bear the costs of permits for special occupancy and use of the specified work areas from the proper agencies. Comply with all requirements regarding signs, advertisements, fires and smoking.

#### **1.2.6.14 12-Month Maintenance and Warranty**

In addition to and not in lieu of any other warranties required under the Contract make all necessary repairs and replacements to remedy, in a manner satisfactory to the District Engineer and at no cost to OLWS, any and all defects, breaks, or failures of the work occurring within 12 months following the date of substantial completion due to faulty or inadequate materials or workmanship. Repair damage or disturbances to other improvements under, within, or adjacent to the work, whether or not caused by settling, washing, or slipping, when such damage or disturbance is caused, in whole or in part, from activities of the Contractor in performing their duties and obligations under this Contract when such defects or damage occur within the warranty period. The 12-month maintenance period required shall, with relation to such required repair, be extended 1 year from the date of completion of such repair.

If Contractor, after written notice, fails within 10 days to proceed to comply with the terms of this section, OLWS may have the defects corrected, and Contractor and Contractor's surety shall be liable for all expense incurred. In case of an emergency where, in the opinion of the District Engineer, delay would cause serious loss or damage, repairs may be made without notice being given to Contractor and Contractor or surety shall pay the cost of repairs. Failure of the District Engineer to act in case of an emergency shall not relieve Contractor or surety from liability and payment of all such costs.

In addition to the above provisions, OLWS waterline facilities installed by the Contractor under this Contract that require repair or replacement during the 12-month maintenance period shall be repaired by OLWS or under the direction of OLWS and the Contractor and Contractor's surety shall be liable for all expenses incurred.

### **1.2.7 Prosecution and Progress of Work**

#### **1.2.7.01 Contractor's Construction Schedule**

Within 30 days of Contract award or 1 week in advance of starting work, whichever is earlier, submit for written approval a proposed construction schedule to the District Engineer. Contractor may not commence work until construction schedule is approved by the District Engineer.

If it is desirable to carry on operations in more than one location simultaneously, submit a schedule for each location at least 1 week in advance of beginning such operations. In the event that the Contractor's proposed construction schedule does not meet the necessary construction program schedule as determined by OLWS, immediately resubmit a schedule that conforms as approved. Contractor shall not commence work until schedule is approved by the District Engineer.

The schedule shall show the proposed order of work and indicate the time required for completion of the major items of work. This working schedule shall take into account the passage and handling of traffic with the least practicable interference therewith and

the orderly, timely and efficient prosecution of work. It will also be used as an indication of the sequence of the major construction operations and as a check on the progress of work.

**1.2.7.02 Preconstruction Conference**

Attend a preconstruction conference, if requested, at a time, prior to start of work, designated by the District Engineer. Comply with information and instructions provided at the preconstruction conference as recorded in the minutes of the meeting.

**1.2.7.03 Notice-to-Proceed**

Unless stated otherwise in the Special Specifications, written Notice to Proceed will be given by the District Engineer within 30 days after the performance and payment bond and all required insurances have been filed with and approved by OLWS and the Contract has been executed. Do not commence work under the Contract until such written notice has been given.

Notice to Proceed may be delayed up to an additional 30 days (for a total of sixty 60 days) from date of Contract by the District Engineer if, in the District Engineer's opinion, necessary easements or permits have not been obtained, or required utility relocation, construction, or reconstruction has not been completed or has not progressed to a degree that will allow initial contract work to commence.

Commence work within 10 working days after the date of the Notice to Proceed, or such other date as may be fixed by the Notice to Proceed, which date shall establish the date for commencement of the Contract time. Notify the District Engineer 48 hours in advance of the time and place work will be started.

**1.2.7.04 Contract Time**

Time shall be considered the essence of the Contract.

Upon commencement of work, Contractor shall provide adequate labor, materials, and equipment, and work shall be performed vigorously and continuously in accordance with a schedule which will ensure completion within the specified time limit. Failure to diligently pursue the work may jeopardize additional contract time.

**1.2.7.05 Suspension of Work**

If the work is suspended for convenience: Temporarily suspend work on the Project wholly or in part for convenience of OLWS as directed by the District Engineer. In the event of such suspension, the District Engineer shall, except in emergency, and except as hereinafter provided, give Contractor 3 days' notice. Work shall be resumed within 5 days after notice has been given by the District Engineer to Contractor to do so. The District Engineer shall allow Contractor an extension of time for completion corresponding to the total period of temporary suspension, and shall reimburse Contractor for necessary rental of unused equipment, services of watch persons, and

other unavoidable expenses accruing by reason of the suspension, as stipulated in Subsection 1.2.7.06, Delays and Extensions of Time.

If work is suspended by the District Engineer: Immediately suspend work on the project, wholly or in part, as directed by the District Engineer, for reasonable periods of time as the District Engineer may deem necessary, when conditions are unsuitable for satisfactory performance of the work. OLWS shall allow the Contractor an extension of time for completion corresponding to the total period of suspension, but the Contractor shall not be entitled to reimbursement for any costs or damages arising under this clause.

If work is suspended for cause: Immediately suspend work on the Project wholly or in part as directed by the District Engineer for such periods as the District Engineer may deem necessary due to: (1) failure to correct unsafe conditions for working personnel, the general public, or OLWS employees, (2) failure to immediately correct defective and unacceptable work in accordance with Subsection 1.2.4.15, (3) failure to carry out provisions of the contract documents and/or conditions of approval, and (4) failure to carry out orders or directives.

Voluntary suspension by Contractor: There shall be no voluntary suspension or slowing of operations without the prior written approval of the District Engineer and such approval shall not relieve Contractor from the responsibility to complete the Contract work within the prescribed Contract time. Should operations be discontinued, Contractor shall notify, in writing, the District Engineer at least 24 hours in advance of resuming operations.

**Responsibilities of Contractor:**

1. At the commencement of and during any suspension of work, protect all work performed to prevent any damage or deterioration of the work. Provide temporary protection devices to warn, safeguard, protect, guide, and inform traffic during suspension, the same as though the work had been continuous and without interferences.
2. Bear all costs for providing suitable provisions for traffic control and for maintenance and protection of the work during suspension unless the suspension was for convenience.

In all cases of suspension, except voluntary suspension by Contractor, work will be resumed only upon written order of the District Engineer or OLWS.

**1.2.7.06 Delays and Extensions of Time**

If the Contractor is significantly delayed due to court orders enjoining the prosecution of this Project, unavoidable strikes, acts of God, unusual and extraordinary action of the elements that are of such severity to stop all progress of the work, or act or neglect of OLWS not authorized by the Contract, the Contractor shall, within 48 hours of the start of the occurrence, give notice to the District Engineer of the cause of the potential delay



and estimate the possible time extension involved. Within 10 days after the cause of the delay has been remedied the Contractor shall give notice to the District Engineer of any actual time extension requested as a result of the aforementioned occurrence.

No extension of time will be considered for weather conditions normal to the area and time of year in which the work is being performed. Delays in delivery of equipment or material purchased by the Contractor or their Subcontractors (including OLWS-selected equipment) shall not be considered as a just cause for delay, when timely ordering would have made the equipment available. The Contractor shall be fully responsible for the timely ordering, scheduling, expediting, delivery, and installation of all equipment and materials. Extensions of time will be considered for delayed delivery of OLWS specified equipment "without equal."

Within a reasonable period after the Contractor submits to the District Engineer a written request for an extension of time the District Engineer will make the decision on each request, for General Manager approval.

An adjustment of Contract time as herein provided shall be the Contractor's sole remedy for any delay in completion of the project arising from causes beyond the control of the Contractor, except for unreasonable delay caused by acts or omissions of OLWS or persons acting therefore. In no event shall the Contractor be entitled to collect or recover any damages, loss or expense incurred by reason of such delay, except for an unreasonable delay caused by acts or omissions of OLWS or persons acting therefor. However, if Contractor is delayed due solely to a breach by OLWS, Contractor will be entitled to recover damages limited to reimbursement for necessary rental of unused equipment, services of watch persons, documented direct overhead costs, documented direct unavoidable expenses accruing by reason of the suspension, plus 15% of the foregoing damages to cover normal Contractor profit. Contractor shall not be entitled to indirect costs or any other damages arising out of the delay, including but not limited to, interruption of schedules, or any other impact claim or ripple effect. If a delay is caused by OLWS and Contractor (joint delay), Contractor shall be entitled to a time extension only, by reason of such joint delay.

#### **1.2.7.07 Liquidated Damages**

Time shall be considered the essence of the Contract. If Contractor fails to complete the project or to deliver the supplies or perform the services within the time specified in the Contract or any extension thereof by OLWS, the actual damage to OLWS for the delay will be substantial but will be difficult or impractical to determine.

It is therefore agreed that Contractor will pay to OLWS, not as a penalty but as liquidated damages, the per diem amount of 0.5% of the total contract or modification thereof for each and every calendar day elapsed in excess of the Contract time or the final adjusted Contract time applicable to the work required under the Contract.

Permitting Contractor to continue and finish the work or any part thereof after the Contract time or adjusted Contract time, as pertinent, has expired shall in no way operate as a waiver on the part of OLWS or any of its rights under the Contract.

Payment of liquidated damages shall not release Contractor from obligations in respect to the fulfillment of the entire Contract, nor shall the payment of such liquidated damages constitute a waiver of OLWS's right to collect any additional damages which may be sustained by failure of Contractor to carry out the terms of the Contract, it being the intent of the parties that said liquidated damages be full and complete payment only for failure of Contractor to complete the work on time.

#### **1.2.7.08 Contractor's Representative**

Designate, in writing before starting work, an authorized representative who shall have complete authority to represent and to act for Contractor, in all directions given by the District Engineer. Contractor, or its authorized representative shall supervise the work, and shall be present on site continually during its progress.

If Contractor or its authorized representative is not present, directions may be given by the District Engineer or their authorized representative to the workmen and such order shall be received and followed. Any direction will be confirmed in writing upon request from the Contractor.

Keep a complete copy of the Plans and Specifications on or near the site at all time.

#### **1.2.7.09 Conflicts, Errors, Omissions, And Additional Drawings**

Check and compare all Plans and Specifications prior to construction and notify the District Engineer of any discrepancies or omissions in order to permit correction by the District Engineer. Coordination of Plans and Specifications is intended. Furnish labor and materials as required for the work. Should any work or materials be reasonably required or intended for carrying the project to completion which are omitted on the Plans and Specifications, furnish same as fully as if particularly delineated or described. The intent of the Plans and Specifications is to show and describe a complete project within the limits stated. Dimensions shown on Plans shall be followed, rather than scale measurements. Whenever it appears that the Plans are not sufficiently detailed or explicit, the District Engineer may furnish additional detail drawings or written instructions and Contractor shall perform the work in accordance with the additional details or instructions.

#### **1.2.7.10 OLWS's Right to Do Work**

Failure or refusal to comply with any of the terms or conditions of the Contract will permit OLWS to supply or correct any deficiency or defect or take other appropriate action without prejudice to any other remedy. Such action by OLWS shall be taken only after 7 days' notice by the District Engineer to Contractor and their surety, unless in the judgment of the District Engineer an emergency or danger to the work or to the public exists, in which event action of the OLWS as set forth above may be taken without any

notice whatsoever. The cost of such action by OLWS shall be deducted from the payment then or thereafter due Contractor. Pay OLWS any costs in excess of such payment due.

#### **1.2.7.11 Termination for Default**

If the Contractor should be adjudged bankrupt, or if they should make a general assignment for the benefit of their creditors, or if a receiver should be appointed on account of insolvency, or if they should refuse to or fail to supply enough properly skilled workmen or proper materials for the efficient prosecution of the Project, disregard laws, ordinances or the instructions of the District Engineer, or otherwise be in violation of any provision of the Contract, OLWS may, without prejudice to any other right or remedy and after giving the Contractor and its surety 7 days' written notice, terminate the services of the Contractor and take possession of the premises and of all materials, tools and appliances thereon as well as all other materials whether on the premises or not, on which the Contractor has received partial payment and finish the work by whatever method it may deem expedient.

In the event action as above indicated is taken by OLWS, the Contractor, or its surety, shall provide the District Engineer with immediate and peaceful possession of all of the materials, tools and appliances located on the premises as well as all other materials whether on the premises or not, on which the Contractor has received any progress payment. Upon termination, in the event that the surety does not complete the Contract, at the election of OLWS, Contractor shall assign any and all Subcontractors and material contracts to OLWS or OLWS designee. Further, the Contractor shall not be entitled to receive any further payment until the work is completed. On completion of the work, determination shall be made by the District Engineer of the total amount the Contractor would have been entitled to receive for the work, under the terms of the Contract, had Contractor completed the work. If the difference between said total amount and the sum of all amounts previously paid to the Contractor, which difference will hereinafter be called the "unpaid balance," exceeds the expense incurred by OLWS in completing the work, including expense for additional managerial and administrative services, such excess will be paid to the Contractor, with the consent of the surety. If, instead, the expense incurred by OLWS exceeds the unpaid balance, the amount of the excess shall be paid to OLWS by the Contractor or their surety. The expense incurred by OLWS as herein provided, and the damage incurred through the Contractor's default, shall be as determined and certified by the District Engineer.

In addition to and apart from the above-mentioned right of OLWS to terminate the employment of the Contractor, the Contract may be canceled at the election of OLWS for any willful failure or refusal on the part of the Contractor to faithfully perform the Contract according to all of its terms and conditions; provided, however, that in the event OLWS should cancel the Contract, neither the Contractor nor its surety shall be relieved from damages or losses suffered by OLWS on account of the Contractor's breach of Contract.

OLWS may, at its discretion, avail itself of any or all of the above rights or remedies and its invoking of any one of the above rights or remedies will not prejudice or preclude OLWS from subsequently invoking any other right or remedy set forth above or elsewhere in the Contract.

None of the foregoing provisions shall be construed to require OLWS to complete the work, not to waive or in any way limit or modify the provisions of the Contract relating to the fixed and liquidated damages suffered by OLWS on account of failure to complete the Project within the time prescribed.

**1.2.7.12 Termination in the Public Interest**

It is hereby agreed that OLWS has the right to terminate the Contract in whole or in part when it is considered to be in the public interest.

In the event the Contract is terminated as being in the public interest the Contractor shall be entitled to a reasonable amount of compensation for preparatory work and for all costs and expenses arising out of the termination excluding lost profits.

The amount to be paid to the Contractor:

1. Shall be determined on the basis of the Contract price in the case of any fully completed separate item or portion of the work for which there is a separate or unit Contract price; and
2. In respect to any other work, the Contractor will be paid a percent of the Contract price equal to the percentage of the work completed.

END OF SECTION

# SECTION 2—STORMWATER AND EROSION CONTROL STANDARDS

## TABLE OF CONTENTS

|       |  |    |
|-------|--|----|
| 2.1   | DEFINITIONS.....                                       | 1  |
| 2.1.1 | Words and Terms.....                                   | 1  |
| 2.1.2 | Abbreviations.....                                     | 5  |
| 2.2   | GENERAL INFORMATION.....                               | 5  |
| 2.2.1 | Relationship to OLWS Rules and Regulations.....        | 5  |
| 2.2.2 | Ownership of Stormwater System.....                    | 6  |
| 2.2.3 | OLWS Authority: Storm/Surface Water System.....        | 6  |
| 2.2.4 | Authority and Purpose.....                             | 6  |
| 2.2.5 | Preliminary Statements of Feasibility: Stormwater..... | 7  |
| 2.2.6 | Objectives.....  | 8  |
| 2.2.7 | Applicability.....                                     | 9  |
| 2.2.8 | Variance.....  | 14 |
| 2.3   | GENERAL STORMWATER STANDARDS.....                      | 16 |
| 2.3.1 | General Policy.....                                    | 16 |
| 2.3.2 | Development Policy.....                                | 17 |
| 2.3.3 | Engineering Policy.....                                | 19 |
| 2.3.4 | Stormwater Standard Detail Drawings.....               | 20 |
| 2.3.5 | Approval of Alternative Materials and Methods.....     | 20 |
| 2.3.6 | Special Design Applications.....                       | 20 |
| 2.4   | PUBLIC STORMWATER SYSTEM EXPANSION.....                | 20 |
| 2.5   | SOURCE CONTROLS.....                                   | 20 |
| 2.5.1 | General Requirements.....                              | 20 |
| 2.5.2 | Source Control Requirements.....                       | 22 |
| 2.6   | STORMWATER MANAGEMENT FACILITY DESIGN.....             | 41 |
| 2.6.1 | Stormwater Management Performance Standards.....       | 42 |
| 2.6.2 | Stormwater Management Facility Sizing Methods.....     | 44 |
| 2.6.3 | General Design Requirements.....                       | 48 |
| 2.6.4 | General Facility Design Requirements.....              | 49 |
| 2.6.5 | Stormwater Facility Design Requirements.....           | 57 |
| 2.7   | STORMWATER DRAINAGE SYSTEM DESIGN.....                 | 79 |
| 2.7.1 | General Conditions.....                                | 79 |
| 2.7.2 | Stormwater Drainage System Requirements.....           | 79 |

|            |   |     |
|------------|---|-----|
| 2.7.3      | Stormwater Drainage System Design Methods.....                                  | 81  |
| 2.8        | CONSTRUCTION REQUIREMENTS .....   | 82  |
| 2.8.1      | General Provisions .....  | 82  |
| 2.8.2      | Erosion Prevention and Source Control Requirements.....                         | 83  |
| 2.8.3      | Establishing Protective Vegetative Cover Upon Completion of Final Grading ..... | 86  |
| 2.8.4      | Plans Required .....  | 86  |
| 2.8.5      | Supplemental Plans.....   | 86  |
| 2.8.6      | Best Management Practices .....   | 89  |
| 2.8.7      | Inspection Requirements .....   | 94  |
| 2.9        | OPERATION AND MAINTENANCE .....   | 95  |
| 2.9.1      | General Requirements .....  | 95  |
| 2.9.2      | Operations and Maintenance Plans Required .....                                 | 96  |
| 2.9.3      | Privately Owned and Maintained Facilities .....                                 | 97  |
| 2.9.4      | Publicly Owned and Maintained Facilities .....                                  | 99  |
| Appendix A | PERMITTING AND SUBMITTAL REQUIREMENTS .....                                     | 100 |
|            | Review and Permitting Requirements .....  | 100 |
|            | Infiltration Testing Requirements.....  | 124 |
| Appendix B | STORMWATER FACILITY GUIDANCE .....  | 133 |
|            | Planting Guide for Vegetated Stormwater Facilities .....                        | 133 |
|            | Stormwater Facility Operations and Maintenance Guidance .....                   | 146 |
| Appendix C | STORMWATER TYPICAL DRAWINGS AND STANDARD DETAILS.....                           | 158 |
| Appendix D | FACILITY SIZING METHODOLOGY AND RESOURCES.....                                  | 159 |
|            | Santa Barbara Urban Hydrograph Method.....                                      | 159 |
|            | Soils Information .....   | 160 |
|            | Hydraulics.....   | 169 |
|            | NOAA Isopluvial Maps .....  | 173 |
| Appendix E | OAK LODGE SIMPLIFIED METHOD .....   | 179 |

## 2.1 DEFINITIONS

---

### 2.1.1 Words and Terms

The Oak Lodge Water Services (OLWS) Standards contain words and terms that apply to and are consistent across the Standards document. Unless the context specifically indicates otherwise, the following words and terms, as used in these Standards, shall have the meanings hereinafter designated:

**Applicant.** See Section 1.0.9 and the OLWS Rules.

**Approved Point of Discharge.** See Section 1.0.9.

**Best Management Practice (BMP).** See Section 1.0.9 and the OLWS Rules.

**Board.** See Section 1.0.9.

**BMP Sizing Tool.** See Section 1.0.9.

**Board.** See Section 1.0.9 and the OLWS Rules.

**Bioswale.** See Section 1.0.9.

**Buffer.** See Section 1.0.9.

**Building Drain.** See Section 1.0.9.

**Building Sewer.** See Section 1.0.9.

**Business Customer.** See Section 1.0.9.

**Contractor.** See Section 1.0.9.

**Conveyance System.** See Section 1.0.9.

**County.** See Section 1.0.9.

**Customer.** See OLWS Rules.

**Customer Charge.** See Section 1.0.9.

**Debris.** See Section 1.0.9.

**Design Storm.** See Section 1.0.9.

**Detention.** See Section 1.0.9.

**Developer's Engineer's Inspector or Engineer's Inspector.** See Section 1.0.9.

**Development.** See Section 1.0.9 and the OLWS Rules.

**Discharge.** See Section 1.0.9.

**District.** Oak Lodge Water Services Authority

**District Employee or District Personnel.** See Section 1.0.9 and OLWS Rules.

**Disturbed Area or Disturbance.** See Section 1.0.9.

**Drainageway.** See Section 1.0.9.

**Dwelling Unit.** See Section 1.0.9.

**Drywell.** See Section 1.0.9.

**Easement.** See Section 1.0.9.

**Ecology.** The Washington State Department of Ecology.

**Emergency.** See Section 1.0.9.

**Engineer.** See Section 1.0.9.

**Enhancement.** See Section 1.0.9.

**Fill.** See Section 1.0.9.

**GIS Geographic Information System.** See Section 1.0.9.

**Groundwater.** See Section 1.0.9.

**Green Infrastructure.** See Section 1.0.9.

**Hazardous Materials.** See Section 1.0.9.

**Hearings Officer.** See Section 1.0.9.

**Highly Erodible.** See Section 1.0.9.

**Impervious Surface.** That surface area, which either prevents, or retards the entry of water into the soil mantle and/or causes water to run off the surface in greater quantities or at an increased rate. Impervious surfaces may include, but are not limited to, rooftops, concrete or asphalt paving, walkways, patios, driveways, parking lots, oiled macadam, gravel, or other surfaces which similarly resist infiltration or absorption of moisture. For purposes of these Standards, standing water areas of SMFs and wetlands shall be considered as impervious surfaces. Permeable pavement SMFs, such as permeable pavement designed to mimic the natural hydrology of the site, are considered impervious surfaces for the purpose of determining project impervious surface area thresholds but may be used as a SMF to mitigate the stormwater from the impervious surface area.

**Industrial Waste.** See Section 1.0.9.

**Infiltration System.** See Section 1.0.9.

**In-Lieu Fee.** See Section 1.0.9.

**In-Line Detention.** See Section 1.0.9.

**Inspector.** See Section 1.0.9.

**Installer.** See Section 1.0.9.

**Intermittent Stream.** See Clackamas County Definition, or definition of “stream” in Section 1.0.9.

**Landscape Architect.** See Section 1.0.9.



**Low Impact Development.** See Section 1.0.9.

**Metro.** See Section 1.0.9.

**Mitigation.** See Section 1.0.9.

**Municipal Separate Storm Sewer System (MS4).** A storm drainage system(s) (including roads with drainage systems, municipal streets, catch basins, curbs, gutters, ditches, manmade channels, or storm drains) as defined in 40 Code of Federal Regulations (CFR) 122.26(b)(8).

**Native Vegetation.** See Section 1.0.9.

**National Pollutant Discharge Elimination System (NPDES) Permit.** See Section 1.0.9.

**Non-Single-Family Customer (or User).** See Section 1.0.9.

**OLWS Rules.** See Section 1.0.9.

**Owner.** See Section 1.0.9.

**Parcel.** See Section 1.0.9.

**Perennial Stream.** See Section 1.0.9.

**Permit.** See Section 1.0.9.

**Permittee.** See Section 1.0.9.

**Person.** See Section 1.0.9.

**Pervious Pavement.** See Section 1.0.9.

**Plans.** See Section 1.0.9.

**Pollutant.** See Section 1.0.9.

**Post-Developed Conditions.** See Section 1.0.9.

**Practicable.** See Section 1.0.9.

**Pre-Developed.** See Section 1.0.9.

**Pretreatment Device or Facility.** See Section 1.0.9.

**Pretreatment or Treatment.** See Section 1.0.9.

**Private Stormwater.** Flows that include stormwater runoff from private properties (i.e., homes, driveways, roads), that may include pipes and other natural drainageways, creeks, streams.

**Private Stormwater System.** See Section 1.0.9.

**Private Storm System.** See Section 1.0.9.

**Professional Engineer (PE).** See Section 1.0.9.

**Property.** See Section 1.0.9.

**Proprietary Stormwater Treatment Device.** See Section 1.0.9.

**Public Right-of-Way (ROW).** See Section 1.0.9.

**Public Stormwater.** See Section 1.0.9.

**Public Stormwater Easement.** Benefitting the public, but managed by Clackamas County unless the easement specifically states “Oak Lodge Sanitary District, or Oak Lodge Water Services District, or Oak Lodge Water Services.”

**Public Stormwater Mainline.** See Section 1.0.9.

**Public Stormwater System.** See Section 1.0.9.

**Redevelopment.** See Section 1.0.9.

**Replaced Impervious Surface.** See Section 1.0.9.

**Retention.** See Section 1.0.9.

**Riparian.** See Section 1.0.9.

**Seasonal High Groundwater.** See Section 1.0.9.

**Sensitive Areas.** See Section 1.0.9.

**Service Connection.** See Section 1.0.9.

**Sewer.** See Section 1.0.9.

**Soil.** See Section 1.0.9.

**Standard Methods.** See Section 1.0.9.

**Stop Work Order.** See Section 1.0.9.

**Source Control.** See Section 1.0.9.

**Storm Drainage.** See Section 1.0.9 Storm Sewer System.

**Storm Sewer.** See Section 1.0.9 Storm Sewer System.

**Stormwater.** See Section 1.0.9.

**Stormwater Mainline.** See Section 1.0.9.

**Stormwater Management.** See Section 1.0.9.

**Stormwater Management Facility (SMF).** See Section 1.0.9.

**Stormwater Management Plan.** See Section 1.0.9.

**Stream.** See Section 1.0.9.

**Structure.** A building or other major improvement that is built, constructed, or installed, not including minor improvements—such as fences, utility poles, flagpoles, or irrigation system components—that are not customarily regulated through zoning codes.

**Top-of-bank.** See Section 1.0.9.

**Undeveloped Land.** See Section 1.0.9.

**User.** See Section 1.0.9.

**User Non-Single-family.** See Section 1.0.9.

**Utility Facilities.** See Section 1.0.9.

**Variance.** See Section 1.0.9.

**WES.** See Section 1.0.9.

**Vegetated Corridor.** See Section 1.0.9.

**Waters of the State.** See Section 1.0.9.

**Wet Weather.** See Section 1.0.9.

**Wetland.** See Section 1.0.9.

**Work Area.** See Section 1.0.9.

## **2.1.2 Abbreviations**

See Section 1.0.9.

## **2.2 GENERAL INFORMATION**

---

The stormwater standards in this document describe requirements and methods for minimizing the hydrologic and water quality impacts of development in areas within OLWS's MS4 area. Implementing these standards will help protect water resources which, in turn, will benefit human health, fish and wildlife habitat, recreational resources, and drinking water.

As land is developed, creation of new impervious surfaces and loss of vegetation increases stormwater runoff during rainfall events, altering the natural hydrologic cycle. Without stormwater management, the changes in runoff and/or discharge patterns lead to reduced groundwater recharge and hydromodification of stream channels. The effects of hydromodification include increased erosion of streambanks, increased incision and/or aggradation of stream channels, reduction of high value riparian habitat, impacts to aquatic organisms, and degradation of water quality.

Runoff flowing from roadways, parking areas, rooftops, and other impervious surfaces also collects pollutants that are transported to streams, rivers, and groundwater. Stormwater pollutants are generally separated into the following categories: suspended solids (sediment), oxygen-demanding pollutants, bacteria, organic carbon, hydrocarbons, metals (cadmium, copper, lead, mercury, and zinc), nutrients (nitrogen and phosphorous), and pesticides/herbicides.

This section describes the authority, purpose, applicability, and administrative review requirements of these Standards.

### **2.2.1 Relationship to OLWS Rules and Regulations**

The following standards, procedures and rules are adopted by reference in OLWS Section 10 of the Oak Lodge Rules and Regulations and have the full force and effect of the OLWS Rules and Regulations.

## **2.2.2 Ownership of Stormwater System**

The public stormwater sewer system is located on or within public and private property. Generally, Clackamas County owns and maintains the stormwater system and associated facilities in the public right-of-way (ROW) or public easements not specifically dedicated to OLWS. Through intergovernmental Memorandum(s) of Understanding, OLWS assists in maintaining some infrastructure in the public rights-of-way through various agreements but is not responsible for the drainage function of that system (e.g., flooding), nor does it maintain information about the location, size, condition, or capacity of that system.

Property owners generally own and maintain stormwater system and associated facilities on private property. In the case of a development, the adjacent property owner may maintain a SMF in the public right-of-way fronting their property, regardless of the authority, ownership or responsibility of the water entering those privately-owned facilities.

## **2.2.3 OLWS Authority: Storm/Surface Water System**

Oak Lodge’s authority is derived from its compliance responsibilities with OLWS’s MS4 permit. Compliance with this permit includes water quality monitoring, associated reporting, assuring new development and construction adheres to stormwater standards for volume, rate and quality and erosion prevention / sediment control and to retrofit existing developed areas to improve water quality. Under this permit, OLWS is not responsible for flood control or flood management or the function of the public or private stormwater system. OLWS is a co-permittee with Clackamas County in this MS4 Permit with authority allocated to each separate jurisdiction. At times, stormwater system deficiencies are identified from a development application analysis or other observations. Corrections or upgrades (exactions) to any deficiencies are determined (required) by Clackamas County as the owner of the system.

Clackamas County is responsible for stormwater compliance within the public rights-of-way and public stormwater easements not dedicated to Oak Lodge. Clackamas County is the regulator of the Goal 5 / Title III natural resources which comprise elements of OLWS’s stormwater system. Clackamas County, as the public stormwater system owner, determines if a downstream analysis is required for capacity or condition analysis or other system function.

Oak Lodge’s responsibility is for stormwater treatment-related alterations to private property and any public easements dedicated to Oak lodge.

## **2.2.4 Authority and Purpose**

OLWS, located in Clackamas County, Oregon, is an intergovernmental entity formed pursuant to Oregon Revised Statutes Chapter 190 for the purpose of providing stormwater and surface water management. It is further declared to be the policy of OLWS to provide and offer stormwater and surface water management services for such areas adjacent to OLWS as may, in the judgment of OLWS, be feasibly served upon such terms, conditions, and rates as OLWS shall determine, and as provided in other applicable federal and state laws.

OLWS, through its Director or other authorized designee or representative, shall have the authority to administer all the requirements, regulations, and provisions set forth in these Standards.

OLWS may promulgate new or amended standards in accordance with the process outlined in the OLWS Rules.

Conformance with these standards shall not be a substitute for, or eliminate the necessity of, conforming with any and all federal, state, and local laws, ordinances, rules and regulations which are now, or may in the future, be in effect. Other applicable regulations may include the hazardous materials storage requirements of Articles 79 and 80 of the Oregon State Fire Code; the Spill Prevention, Countermeasure, and Containment Regulations of §40.112 of the Code of Federal Regulations (CFR) administered by the Environmental Protection Agency (EPA); the Resource Conservation and Recovery Act; or Willamette Basin Total Maximum Daily Load (TMDL) Programs regulated by the DEQ.

Any provisions or limitations of these standards are suspended and supplemented by any applicable federal, state, or local requirements existing or adopted subsequent hereto which are more stringent than the provisions and limitations contained herein. In the event of a conflict, the most stringent local, state, or federal regulations generally apply.

The purpose of these Standards is to provide a consistent policy under which certain physical aspects of stormwater system design will be implemented. Many of the elements contained in this document are public works oriented and are related to public improvements; however, it is intended these Standards apply generally to private work designated herein. Generally, public work is to be regulated by CC DTD.

### **2.2.5 Preliminary Statements of Feasibility: Stormwater**

OLWS signs preliminary statements of feasibility for Stormwater management as the Stormwater management authority subject to the following conditions:

- The property owner is responsible for substantiating Stormwater compliance and performance. This is demonstrated through a preliminary stormwater report and plan submitted for the preliminary statement of feasibility.
- OLWS does not own the stormwater system and cannot authorize connections to that system. The owner of the system reconciles existing capacity to proposed impacts with Clackamas County DTD and may include downstream analysis.
- OLWS's authority is derived from its compliance responsibilities with OLWS's MS4 permit. Compliance with this permit includes water quality monitoring, associated reporting, assuring new development and construction adheres to stormwater standards for volume, rate and quality and erosion prevention / sediment control and to retrofit existing developed areas to improve water quality, perform watershed assessment. Under this permit, OLWS is not responsible for flood control or flood management or the function of the public or private stormwater system.
- OLWS is a co-permittee with Clackamas County in this MS4 Permit with authority allocated to each separate jurisdiction. At times, stormwater system deficiencies are identified from a development application analysis or other observations. Corrections

(exactions) to any deficiencies are determined (required) by Clackamas County as the owner of the system. may require use of public easements which OLWS cannot determine access rights.

Other conditions may apply depending on the proposal.

## **2.2.6 Objectives**

The objectives of the Stormwater Standards are as follows:

- Meet federal and state National Pollutant Discharge Elimination System (NPDES) Municipal Separate Storm Sewer System (MS4) permitting requirements.
- Minimize the discharge of pollutants and provide water quality treatment of stormwater runoff to preserve the beneficial uses of drainageways, lakes, ponds, wetlands, and other Sensitive Areas.
- Minimize stormwater runoff volumes and maximize groundwater recharge through the process of infiltration of runoff into vegetated stormwater facilities.
- Maintain the pre-development stormwater runoff characteristics to minimize effects on the drainageways, such as erosion and degradation, generally associated with urbanization.
- Protect the safety of persons and property by safely conveying all stormwater runoff from site development and preventing the uncontrolled or irresponsible discharge of stormwater onto adjoining public or private property.
- Construct SMFs which are safe, effective, and economical to maintain and minimize future replacement costs.
- Provide for orderly development by preserving the drainageways and natural stormwater drainage systems shaped by the existing topography and creating man-made stormwater drainage systems with adequate capacity for future development upstream.
- Provide guidance to designers and engineers in meeting the requirements of stormwater regulations when developing land and constructing infrastructure within OLWS.
- Protect soil, groundwater, and surface water by capturing pollutants and reducing impacts to the environment.
- Redirect flows to the sanitary sewer from areas with the potential for relatively consistent wastewater discharges and manage areas that have potential for pollutant releases or spills with containment or disposal.
- Prioritize structural controls over operational procedures to provide permanent and reliable source control.
- Minimize the movement of soil during construction and the associated impacts to water quality through proper erosion prevention and sediment control practices.

## 2.2.7 Applicability

These Standards shall govern design, construction, and upgrading of all privately financed Stormwater Systems in OLWS and applicable work within OLWS, unless it is shown that OLWS’s authority to impose these standards are superseded by another local jurisdiction.

Some facilities may be required to obtain a NPDES Industrial Stormwater General Permit 1200-Z (1200-Z Permit) issued by DEQ before discharging to the Public Stormwater System or to Waters of the State. The 1200-Z Permit includes discharge benchmarks for facilities with industrial activities that are exposed to rainfall and stormwater runoff. The state also has water quality standards listed in Oregon Administrative Rules (OAR) 340 Division 041 for discharges to surface waters.

Applicants may be required to obtain an Industrial Wastewater Discharge Permit from the local wastewater service provider for discharges to the sanitary sewer system. Facilities subject to these requirements are generally commercial or industrial. Typical discharges include process wastewater, cooling water, or other discharges generated by some of the sources that are required to drain to a sanitary sewer system.

The requirements presented in these Standards do not exclude or replace the requirements of other applicable codes or regulations, such as the Willamette TMDL Program, the Industrial NPDES Permitting Program, or any other applicable federal or state regulations or permit requirements.

All development within Federal Emergency Management Agency (FEMA) regulated streams and floodplain overlay zones may be required to meet the FEMA floodplain requirements and the requirements of the local planning and building authority.

If it is determined by OLWS that stormwater management or stormwater drainage system facilities, in addition to the onsite facilities required by these standards, are necessary to manage and protect natural resources, Public Stormwater Systems, and/or private property effectively, OLWS may require additional facilities or modifications at the sole discretion of OLWS.

Table 1 lists the stormwater minimum requirements and the applicable design standards within these Standards.

*Table 1. Stormwater Minimum Requirements*

| STORMWATER MANAGEMENT   |   |
|---|---|
| Threshold   | Minimum Requirements  |
| Development or redevelopment proposing less than 1,000 square feet (sf) of impervious surface areas, including the cumulative impervious surface area that was developed/redeveloped over the last 3 years. | Verify impervious areas through submission of a site plan that shows the exact square footage of all new or replaced impervious surfaces. No stormwater permit likely required. |
| Development or redevelopment proposing a minimum of 1,000 square feet up to a maximum of 10,000 square feet of new or re-constructed  | Stormwater Permit Required using the Simplified Method. (See Appendix E)  |

| <b>STORMWATER MANAGEMENT</b>  |  |
|---|--|
| <b>Threshold</b>  | <b>Minimum Requirements</b>  |
| <p>impervious surface (including any potential right-of-way improvements); or Oak Lodge may, at its discretion, require complex sites proposing less than 10,000 square feet to design to the engineered method described in row #3.</p>  | <p>Flow Control and Water Quality Treatment Required.<br/>           Facility Sizing: Tiered size with no engineering requirement; use the OLWS simplified method.<br/>           Design is per OLWS detail drawing(s).<br/>           Submit the following:</p> <ul style="list-style-type: none"> <li>• Site plan</li> <li>• Detail drawing(s)</li> <li>• Infiltration rate (simplified form)</li> <li>• Facility sizing calculations</li> <li>• Maintenance agreement</li> </ul>  |
| <p>Development or redevelopment proposing greater than 10,000 square feet of impervious surface areas, including the cumulative impervious surface area that was developed/ redeveloped over the last 3 years.</p> <p>Or</p> <p>Any (0.1 square feet or greater) of impervious surface is proposed as new or replaced in a designated natural resource area or associated buffer discharging stormwater runoff to a natural or manmade stormwater drainage system or infiltration facility.</p> | <p>A stormwater permit is required. Water quality treatment, flow control, and detention and retention are required.</p> <p>At a minimum, submit a Preliminary Site Plan, engineered storm report and design drawings.</p> <p>Design and construct SMF(s) to meet the flow control, and water quality performance standards as calculated by the BMP sizing tool or engineered method as described in Section 2.6.2.</p> <p>Execute and record an Operations and Maintenance (O&amp;M) Plan for stormwater facilities on private property or those required to be in the public ROW for any associated improvements.</p> |
| <p>Development or redevelopment that is categorized as high risk for increased stormwater pollutant loading</p>   | <p>Design and implement applicable source controls (see Section 2.5).</p>  |

| <b>EROSION CONTROL</b>   |  |
|--|--|
| <b>Threshold</b>   | <b>Minimum Requirements</b>  |
| <p>Development or redevelopment proposing less than one acre of disturbance regardless of parcel size in the following categories:</p> <ol style="list-style-type: none"> <li>(1) 500 square feet or greater of ground disturbance is proposed.</li> <li>(2) 250 square feet or greater of ground disturbance is proposed in a designated natural resource area or associated buffer               <ol style="list-style-type: none"> <li>a. Examples include construction, reconstruction, demolition, tree removal, site preparation,</li> </ol> </li> </ol> | <p>An erosion control small lot permit is required. Develop Erosion Prevention and Sediment Control (EPSC) Plans and obtain EPSC Permit for a “small lot”.</p> |



| <b>EROSION CONTROL</b>  |  |
|---|--|
| <b>Threshold</b>  | <b>Minimum Requirements</b>  |
| <p style="text-align: center;">mitigation activities, brush removal, grading and/or clearing.</p> <p>(3) Generally, utility trenching is exempt unless the trench is in a designated natural resource or associated buffer, constitutes a potential hazard or will be open for more than 72 hours or is otherwise subject to erosion potential.</p> |  |
| <p>An erosion control 1200CN permit is required for ground disturbing proposals of one acre to five acres of disturbance or if the project involves phases that collectively constitute more than one acre of disturbance.</p>  | <p>A 1200CN Permit is required. The owner shall supply all required materials. Develop Erosion Prevention and Sediment Control (EPSC) Plans and obtain EPSC Permit</p> |
| <p>An erosion control 1200C permit is required for ground disturbing proposals of five acres and greater of disturbance or if the project involves phases that collectively constitute more than one acre of disturbance.</p>   | <p>Obtain a 1200C permit from DEQ and provide the issued permit to Oak Lodge.</p>  |

**2.2.7.01 Stormwater Management Requirements**

All new Development and Redevelopment activities that result in 10,000-sf or greater of new or replaced impervious surface area, cumulative over the last 3 years, are subject to the requirements of these Standards for all newly proposed and replaced impervious surface areas within the overall project boundary. Examples of this include residential development and construction such as subdivisions or partitions including all new public and/or private roadways, sidewalks, curbs, driveways, and roof areas; non-residential development including structure roof area, parking and vehicle maneuvering area, walkways, and other surfaces.

Stormwater runoff from all the Developed and Redeveloped impervious surface areas shall be treated in accordance with these Standards.

- Water quality facilities shall be designed to capture and treat the first 1 inch of stormwater runoff from a 24-hour storm event. The water quality facility shall use either an approved vegetated SMF or an approved Proprietary Stormwater Treatment Device if infiltration is not possible.
- All existing site development that desires to change the existing point of discharge and the stormwater runoff from impervious areas exceeds the 10,000-sf impervious threshold shall comply with these Standards, and for design criteria purposes the impervious area will be considered as redevelopment.

- All Development and Redevelopment activities that result in the creation of private stormwater facilities must execute and record an Operations and Maintenance Plan (with the exceptions of Table 1).
- All private stormwater drains outside the building envelope shall be designed using these standards, along with the Oregon Structural Code, Oregon Plumbing Specialty Code (OPSC), and/or other applicable codes as appropriate.
- The stormwater management requirements are in addition to the applicable source control and erosion control requirements.

### **Exemptions**

Projects in the following categories are exempt from the stormwater minimum requirements:

- A. Residential structures being re-built following fire damage, flooding, earthquake, or other natural disasters, as long as the structure is re-built at the same scale and discharging to the same disposal point. Expansions to the original footprint, such as an addition or alteration to the original structure, may trigger stormwater management requirements for the expanded impervious area (reference Table 1).
- B. Interior remodeling projects and tenant improvements.
- C. Stream enhancement or restoration projects as approved by OLWS.
- D. Farming practices as defined by Oregon Revised Statutes (ORS) 30.930 and farm use as defined in ORS 214.200 and including farm roads, including farm structures and farm access roads outside the Urban Growth Boundary where stormwater is managed through dispersion with no direct connection to the public drainage system. Buildings associated with farm practices and farm access roads are subject to the requirements of these standards if there is a direct discharge to a Stormwater Drainage System. Residential homes proposed to be built on farmland are not exempt from these Standards.
- E. Forest practices as defined by ORS 527.610.
- F. Modular/temporary structures and/or surfaces that will be removed at the completion of the project and do not have a direct connection to the Stormwater Drainage System.
- G. Actions by a public utility or any other government agency to remove or alleviate an emergency condition.
- H. Underground utility projects that replace the ground surface with in-kind material or materials with similar runoff characteristics.
- I. Non-pollution generating, linear projects (e.g., pedestrian and bicycle pathways, sidewalks, trails, and ramps not included in a larger project) that disperse

stormwater runoff into vegetated areas, as long as the pathways do not include inlets connected to the Stormwater Drainage System.

- J. Stormwater Drainage Systems shall be designed to meet the requirements of Section 2.5, except when the Development/Redevelopment is not above the impervious thresholds listed in this section, and the stormwater drainage system is located entirely on a privately-owned parcel, is privately maintained, and receives no stormwater from outside the parcel's property limits. Those systems exempted from the stormwater drainage system requirements will remain subject to the requirements of the OPSC and shall be reviewed by the building official.
- K. Unfeasible treatment areas including, but not limited to the following (subsection a-f). Rather than being completely exempted as the examples in A-K above, the following shall add the relevant impervious area in terms of square feet to the proposed treatment facility(ies) with a multiplier of "2"<sup>1</sup>. The below examples shall be used to calculate the entire project's impervious square feet of impervious for standard compliance as stated in Table 1 and other areas of the document. If this exchange is used, the application shall explicitly describe this, enumerate the area(s), and show the area(s) on submitted plans.
  - a. impervious areas downstream from the treatment facility that are demonstrated to be impossible to capture and treat.
  - b. areas within the public right-of-way which demonstrate a deficiency in area or dimension to install a SMF.
  - c. driveway extensions into the public ROW and including road approaches and aprons
  - d. elevation/ topography that cannot be altered to convey stormwater to a facility
  - e. generally, ROW improvements such as half-street improvements can use the treated area exchange as described above.
  - f. Other proposals may be approved at the sole discretion of the OLWS Engineer with all variance criteria addressed.

#### **2.2.7.02 Source Control Requirements**

Source control requirements apply to all developments and redevelopments with high-risk characteristics during new development, redevelopment, tenant improvements, or when existing sites proposing new offsite discharges.

Source controls shall be applied to the areas of the site with high-risk characteristics as well as any areas hydraulically connected to a high-risk area. With redevelopment

---

<sup>1</sup> For example, if the exchange area is 1,000 sf the facility shall be sized to accommodate an additional 2,000 sf

projects, only areas that are being disturbed with the redevelopment are required to make structural source control changes.

Projects with the following site uses/characteristics are considered to be high-risk and are subject to source control requirements in Section 2.5:

- A. Fuel Dispensing Facilities and Surrounding Traffic Areas
- B. Above-Ground Storage of Liquid Materials
- C. Recycling and Solid Waste Storage Areas
- D. Exterior Storage of Bulk Materials
- E. Material Transfer Areas/Loading Docks
- F. Equipment and/or Vehicle Washing Facilities
- G. Equipment and/or Vehicle Repair Facilities
- H. Land with Suspected or Known Contamination
- I. Covered Vehicle Parking Areas for Commercial or Industrial Uses
- J. Industrial and Commercial High Traffic Areas

Applicants are required to address all high-risk site characteristics listed above. For example, if a development includes both a fuel dispensing area and a vehicle washing facility, the source controls in both those sections will apply.

The source control requirements are in addition to the applicable stormwater management and erosion control requirements. Developments that have existing or proposed offsite SMFs are not exempt from the source control requirements.

### **2.2.7.03 Erosion Prevention and Sediment Control Requirements**

All development as described in Table 1 shall be subject to the Erosion Prevention and Sediment Control (EPSC) requirements of Section 2.8.2. The Permittee shall be required to obtain an EPSC Permit, unless otherwise excluded by OLWS.

The erosion control requirements are in addition to the applicable stormwater management and source control requirements.

## **2.2.8 Variance**

Alternative materials and methods will only be accepted if the Applicant can demonstrate that the existing standards are not appropriate for a given site and the proposed alternative provides the same or greater level of performance as defined in these standards. Alternate materials or methods not explicitly approved herein will be considered for approval through the variance process outlined below.

### **2.2.8.01 Variance Request**

A variance request to the Standards shall be submitted in writing to OLWS. The written request for a variance should be submitted to OLWS prior to land use approval if a land

use action is required. Land use conditions of approval are commonly written so there is little, if any, flexibility after land use approval is issued. If land use approval has already been issued or is not required, then the variance request should be submitted in writing along with the first plan review submittal.

Once OLWS approves the plans, a variance request will only be accepted at the discretion of OLWS, and if the request is the only feasible solution without regards to delays or cost. Only minor variance requests will be considered during the construction phase of the project to address a specific design or construction problem. It is the responsibility of the Applicant to obtain all approvals from any local, county, state or federal authority having any jurisdiction or permitting of the activities before proceeding with an approved variance.

This written request shall include the following:

- A. The desired variances(s);
- B. The reason(s) for the request(s);
- C. A quantitative comparison between the specification(s) and standard(s) and the variance(s) for performance in terms of water quality treatment, detention and retention and infiltration, and include an analysis of comparative function, maintainability, safety, and any other applicable criteria as determined reasonable by OLWS;
- D. References to regionally and/or nationally accepted standards, records of successful use by other agencies or other supportive information.

#### **2.2.8.02 Criteria for Variance**

OLWS may grant a variance when the request does not compromise the following: public safety, environmental protection, maintenance/repair/replacement, and when any one of the following conditions are met:

- A. Topography or other geographic conditions impose an environmental or safety concern and the request is considered an equivalent alternative, which can accomplish the intent and criteria that is provided in these standards.
- B. A minor change to the standard is required to address a specific design or construction problem which, if not enacted, will result in an unreasonable or disproportionate burden or obstacle to development. The financial viability of meeting the requirements of these design standards is not in itself a justification for a design exception.
- C. The variance request is in the public interest and requirements for safety, function, appearance, and maintainability are based upon sound engineering and functionality of the proposed system is a feasible alternative.

All requests will be evaluated on a case-by-case basis, and approval of alternative materials and methods for one development proposal will not imply an approval under similar circumstances in another proposal. Approval of a variance, or denial of a site-

specific request shall not constitute a precedent for use at other locations with potentially similar circumstances.

#### **2.2.8.03 Review Process**

The request for variance shall be reviewed by OLWS. OLWS shall make one of the following decisions:

- A. Approve as proposed, or
- B. Approve with changes, or
- C. Deny with an explanation.

It is the responsibility of the Applicant to obtain all approvals from any local, county, state or federal authority having any jurisdiction or permitting of the activities before proceeding with an approved variance.

#### **2.2.8.04 Appealing Variance Request Decision**

The Applicant may make a written request to OLWS to appeal the variance request decision as outlined in the appeals process contained in Section 12 of OLWS Rules and Regulations. The request must accompany a complete set of application materials.

## **2.3 GENERAL STORMWATER STANDARDS**

---

This section of the Stormwater Standards presents an overview of the general policies, methods, and processes associated with the Stormwater Standards as a whole.

### **2.3.1 General Policy**

Public improvements are conditioned through the development review and land use approval process, described, and administered under the local planning department administering the zoning and development ordinance, or by federal, state, or other local government regulation. These Stormwater Standards cannot provide for all situations and are intended to assist, but not to substitute for competent work by design professionals. It is expected that the design professionals will bring to each project the best of skills from their respective disciplines.

These Stormwater Standards are not intended to limit unreasonably any innovative or creative effort that could result in better quality, cost savings, or both.

General stormwater requirements for all projects and developments are as follows:

- A. OLWS does not allow the diversion of stormwater runoff from one watershed to another watershed.
- B. All public stormwater drainage systems shall be gravity systems without the use of pumps or other mechanical means to convey or transport stormwater.
- C. The Approved Point of Discharge for all stormwater may be a piped system or open channel as approved by OLWS in conjunction with CC DTD. All outfalls to an existing or proposed stormwater facility, stormwater system, drainageway, or surface water system shall be approved by OLWS.

- D. The Approved Point of Discharge for surface water, stormwater and/or groundwater shall not be a sanitary sewerage system, except as provided in Section 2.5.
- E. No project shall directly or indirectly discharge, to the public stormwater system, any quantity of stormwater, pollutant, substance, or wash water that will violate the Discharger's permit (if one is issued), OLWS's NPDES MS4 permit, or other environmental laws or regulations.

### **2.3.2 Development Policy**

Requirements for development of a property or a tract of land are as follows:

- A. Design of surface water and stormwater systems must include provisions to control runoff from impervious and pervious areas within and upstream of the development without exceeding capacities of available facilities and downstream drainageways.
- B. Development proposals shall maintain the natural drainage pathways for seasonal and intermittent drainages or provide alternate manmade natural drainage pathways.
- C. Pre-existing surface or subsurface drainage, caused or affected by development, shall not flow over adjacent public or private property in a volume, flow rate or location significantly different from that which existed prior to development, but shall be collected and conveyed to an acceptable point of discharge as approved by OLWS.
- D. Surface drainage entering a development from offsite areas shall be intercepted at the naturally occurring locations. Offsite surface drainage shall be conveyed through the site in a separate stormwater drainage system and will not be mixed with the stormwater collected and treated within the onsite SMFs unless the onsite SMFs are designed to manage and treat the additional flows from the upstream drainage basin(s) assuming full development potential.
- E. When an Approved Point of Discharge is located and/or conveyed on an adjacent private property, the Applicant shall be responsible to acquire all applicable downstream private and/or Public Stormwater Easements. An easement is not necessary if the point of discharge is considered an intermittent stream, perennial stream, river, wetland, or natural resource.
- F. In compliance with Oregon Drainage Law, development shall not adversely impact downstream properties. Stormwater runoff from a development shall be safely conveyed to prevent the uncontrolled or irresponsible discharge of stormwater onto adjoining public or private property.
- G. Development shall not cause or increase flooding of adjacent or downstream property. Flow control standards are intended to limit input to the system at no greater rate than the undeveloped condition. Clackamas County may require an upstream and downstream analysis of the drainage system.
- H. All development, regardless of permit status, shall keep sediment laden water and any other forms of stormwater pollution from entering natural drainage systems, wetlands, natural resources, and the Public Stormwater System.

- I. All development must obtain a Service Provider Letter from OLWS prior to applying for Land Use/Design Review to the local planning authority. To obtain the Service Provider Letter from OLWS the Applicant must demonstrate that the proposed development is viable in accordance with OLWS Rules and Standards. The Service Provider Letter will only be issued once the Applicant has provided sufficient plans, reports, and studies needed for preliminary review by OLWS. Based on the preliminary review, OLWS may request additional information prior to issuance of the letter or as part of the forthcoming land use application. Receipt of the Service Provider Letter does not imply that all OLWS requirements have been met or guarantee that land use approval for the development will be granted. Service Provider Letter submittal requirements are found in Appendix A.
- J. Developments subject to O&M requirements are required to submit an O&M Plan and shall include an agreement that allows OLWS Personnel access to the SMFs for inspections or abatement of a public nuisance or to correct a violation of these Standards.
- K. All publicly maintained SMFs shall be fully located in the Public ROW or within a tract of land that has adequate maintenance access and rights dedicated to Public, and the Stormwater Drainage System(s) shall be located within an easement or tract of land that has rights dedicated to Public; not specifically OLWS. Typically, any SMF in a public ROW that is a component of any development action is maintained by the associated property(ies) of that development.
- L. A public drainage easement is required on existing open drainages that conveys Public Stormwater. The easement shall be dedicated to the Public and not to OLWS.
- M. Surface or subsurface drainage, caused or affected by the changing of the natural grade of the existing ground or removal of natural ground cover or placement of impervious surfaces, shall not be allowed to flow over adjacent public or private property in a volume or location materially different from that which existed before development occurred, but shall be collected and conveyed in an approved manner to an approved point of disposal.
- N. Stormwater and surface water entering the subject property shall be received at the naturally occurring locations and stormwater and surface water exiting the subject property shall be discharged at the natural locations with adequate energy dissipaters within the subject property to minimize downstream damage and with no diversion at any of these points.
- O. The approved point of disposal for all stormwater may be a storm drain or a detention or retention pond or other approved by Clackamas County or other relevant agency. Existing open channels, creeks or streams are approved points of disposal after the stormwater has been treated for water quality. Acceptance of proposed systems will depend upon the prevailing site conditions, capacity of existing downstream facilities, and functional performance of the alternate design.



- P. When private property must be crossed in order to reach an approved point of disposal, it shall be the owner's responsibility to acquire a recorded drainage easement. Temporary drainage ditch facilities, when approved, must be engineered to contain the stormwater without causing erosion or other adverse effects to the private property.
- Q. All stormwater drain system designs shall make adequate provisions for collecting all stormwater runoff. The system shall accommodate all runoff from upstream tributary areas whether or not such areas are within the proposed development. The amount of runoff to be accommodated shall be based upon ultimate development of all upstream tributary areas.
- R. Proposed stormwater drain systems shall not discharge flows into inadequate downstream systems unless approved by Clackamas County or relevant agency. The Owner must obtain all necessary permits (Division of State Lands, Army Corps of Engineers, Oregon Department of Fish and Wildlife, etc.).
- S. Public drainage facilities shall comply with Clackamas County standards, unless amended by OLWS with CC DTD approval.
- T. In the event a development or any part thereof is traversed by any water course, channel, stream or creek, gulch or other natural drainage channel, adequate easements for purposes of stormwater and surface water drainage maintenance shall be provided. The easement shall be dedicated to the public, but not to OLWS. Oak Lodge does not assume any maintenance obligation.
- U. Facilities developed on site, including flow discharge from site, shall be constructed in a manner consistent with "OLSD Surface Water Master Plan".
- V. Following completion of construction, the engineer shall submit a document, stamped by a professional engineer, indicating all stormwater systems have been inspected and installed per approved plans and approved changes.
- W. Maintenance is required for all onsite stormwater facilities. The maintenance program must be approved by OLWS. OLWS may require a recorded Operations and Maintenance Agreement for onsite facilities.
- X. Site plans, grading plans, stormwater drainage plans, and associated calculations must be stamped and signed by a professional engineer licensed by the State of Oregon and meet the standards of OLWS.
- Y. Development projects shall not be phased or segmented in such a manner to avoid the requirements of the Code or Standards.
- Z. The owner is also responsible for springs and groundwater that surface during construction and within the warranty period of the drainage system.

### **2.3.3 Engineering Policy**

See Section 1.0.2.

### **2.3.4 Stormwater Standard Detail Drawings**

See Section 5 – STANDARD DRAWINGS

### **2.3.5 Approval of Alternative Materials and Methods**

See Section 1.0.6.

### **2.3.6 Special Design Applications**

Special applications not covered in these Standards require review and approval by OLWS. Submittal of full design calculations, supplemental drawings, and other information shall be required before any approval is considered.

In the Oak Lodge boundary, Clackamas County owns and maintains public stormwater and surface water assets. Any development proposals that require construction of public stormwater assets, repair, or alterations are under the jurisdiction of Clackamas County.

## **2.4 PUBLIC STORMWATER SYSTEM EXPANSION**

---

This section heading is retained for numbering consistency with WES. The content is removed as Oak Lodge does not own or regulate the public stormwater system construction. WES owns and maintains some public stormwater and surface water assets. The WES chapter only applies to development proposals that require construction of public stormwater assets that are intended to be conveyed to WES. In Oak Lodge, Clackamas County DTD performs this function.

## **2.5 SOURCE CONTROLS**

---

This section presents the source control requirements for site uses and characteristics that have the potential to generate higher levels of pollutants than typical stormwater runoff.

The site characteristics/uses in this section have been identified as potential sources of chronic loadings or acute releases of pollutants such as oil and grease, toxic hydrocarbons, heavy metals, toxic compounds, solvents, abnormal pH levels, nutrients, organics, bacteria, chemicals, and suspended solids. This section presents controls for managing these pollutants at their source.

These controls are not intended to supersede any Clackamas County Fire or building permit-related, or any OSHA requirements and are intended to be complimentary to these. The Source Control requirements are intended to fill a regulatory gap from secondary containment to protecting OLWS's assets and the public's stream system.

### **2.5.1 General Requirements**

The following requirements apply to all sites subject to source control.

### **2.5.1.01 Signage Requirements**

Informational signage is required for some site uses and activities that have the potential to contaminate stormwater. Proper signage addresses good housekeeping rules and provides emergency response measures in case of an accidental spill.

All signage shall conform to the following requirements:

- A. Signs shall be located and plainly visible from applicable activity areas.
- B. More than one sign may be needed to accommodate larger activity areas.
- C. Signs shall be water and weather resistant.
- D. Signs shall include the following information:
  - a. Safety precautions
  - b. Immediate spill response procedures (for example: “Turn the valve located at...” or “Use absorbent materials”)
  - c. Emergency contact(s) and telephone number(s)
- E. Signs may need to be in more than one language if required to communicate effectively with employees and delivery personnel.
- F. Signs may need to meet retro-reflectivity standards dependent on the use and intent of the sign.

### **2.5.1.02 Spill Control**

Spill response supplies, such as absorbent material, containment booms, and protective clothing, shall be available at all potential spill areas. Any applicable spill response supplies need to be clearly marked and located where the signage is posted and near the high-risk activity area. The spill response supplies should be appropriate to the nature of the potential risk present at the site. More than one spill response kit may be necessary to accommodate larger activity areas.

Employees should be familiar with the site’s O&M Plan; the site’s Spill Prevention, Countermeasure, and Containment plan; and/or proper spill cleanup procedures.

### **2.5.1.03 Public Sanitary Sewer Discharge Permit**

Many source control strategies require a connection of private stormwater drains to the public sanitary sewer system. Connection/discharge to the public sanitary sewer system requires prior written approval by OLWS. A request to discharge to the public sanitary system shall be submitted as part of the permitting process. All impervious surface areas that can drain into the public sanitary sewer shall be designed in a manner to eliminate stormwater runoff from entering the sanitary sewer system. The separation of stormwater into the sanitary sewer system is generally accomplished by covering the impervious area that drains into the sanitary sewer and grading the area in a manner that separated the flows.

## 2.5.2 Source Control Requirements

Applicants shall show the locations of proposed structural source controls (including spill control manholes and shutoff valves) and include documentation of high-risk site uses and the applicable source controls as part of the Stormwater Report and Stormwater Plans (see Appendix A for submittal requirements).

### 2.5.2.01 Fuel Dispensing Facilities and Surrounding Traffic Areas

These requirements apply to all development where vehicles, equipment, or fuel tanks are refueled on the premises, whether it is a gas station, a single-pump maintenance yard, or a small-sized fuel tank. A fuel dispensing facility is defined as the area where fuel is transferred from bulk storage tanks to vehicles, equipment, and/or mobile containers (including fuel islands, above- or below-ground fuel tanks, fuel pumps, and the surrounding pad). Propane tanks are exempt from these requirements.

Any discharge or point of connection to the public or private stormwater system must obtain authorization and permitting by OLWS. Discharges of hydrocarbons are prohibited to the public sanitary and stormwater sewer systems. When a containment or emergency storage device is used, the Owner or responsible person shall contact OLWS's Environmental Monitoring Division for authorization to open any valve and discharge any substance to a public sanitary or stormwater sewer system. OLWS shall determine the conditions to discharge or dispose of the substance to safeguard the environment, public health, and safety.

Underground storage tanks or installations requiring a Water Pollution Control Facility (WPCF) permit are exempt from these requirements but must go through DEQ's WPCF permit process.

#### Cover

The fuel dispensing area shall be covered with a permanent canopy or roof so precipitation cannot come in contact with the fueling activity area. Rainfall shall be directed from the cover to a stormwater disposal point that meets all applicable code requirements.

Covers 10 feet high or less shall have a minimum overhang of 3 feet on each side. The overhang shall be measured relative to the perimeter of the hydraulically isolated fueling activity area it is to cover.

Covers higher than 10 feet shall have a minimum overhang of 5 feet on each side. The overhang shall be measured relative to the perimeter of the hydraulically isolated fueling activity area it is to cover.

#### Pavement

A paved fueling pad of concrete shall be placed under and around the fueling activity area and shall meet all applicable building code requirements. Sizing of the paved area shall be adequate to cover the activity area, including placement and number of vehicles or pieces of equipment to be fueled by each pump. Fuel pumps shall be located a minimum of 10 feet from the edge of the fueling pad.

## **Drainage**

The impervious area beneath the cover shall be hydraulically isolated from the surrounding area through grading, berms, or drains.

Drainage from under the cover that is hydraulically isolated shall be directed to the sanitary sewer system. When connecting to sanitary sewer, an oil/water separator shall be installed to collect and detain the runoff from under the cover of a fuel dispensing area. Unless OLWS requires a different volume, the minimum storage capacity of the oil/water separator and, if needed, an upstream storage sump/vault shall be 1,000 gallons. A flow-stop or shut-off valve is required downstream of the oil/water separator prior to connection with the public sanitary sewer system.

Surrounding runoff must be directed away from the hydraulically isolated fueling pad to a stormwater discharge point that meets all stormwater management requirements of these standards and other applicable code requirements.

Traffic pathways that surround fueling pads are considered high use/high-risk areas and will require a valve on the stormwater drainage system. Valves installed on stormwater drainage systems must be installed downstream of all applicable private SMFs to accommodate spill containment. These valves must be left open to facilitate stormwater flows during normal conditions, and immediately closed in the event of a spill.

### **Pretreatment: Oil/Water Separator**

Runoff from the fuel dispensing area is required to be pretreated in an oil/water separator with coalescing plates prior to being discharged into the spill control manhole. The purpose of the device is to treat runoff from washing down and cleaning of the fueling area and to prevent small spills from entering the spill control manhole.

Coalescing plate separators shall be designed to achieve a 100 parts per million (ppm) non-polar oil and grease limit in the effluent from the peak flow generated by the washing activity. Testing information must be submitted by the manufacturer of the unit that supports the 100 ppm effluent standard at the calculated flow rate.

At a minimum, the device will be sized to treat the standard flow from a 5/8-inch hose which is estimated to be 10 gallons per minute.

Each device shall be verified with the vendor to assure the treatment and flow rate capacity are within the parameters of the device.

Separator details must be shown on the building plans submitted at the time of building permit application and shall match manufacturer specifications and details, including the unit flow rate, effluent water quality, and maximum process flow rate.

All separators shall be maintained per the manufacturer specifications and the private maintenance plan approved by OLWS.

### **Spill Control Manholes**

A spill control manhole shall be installed as the last device inline to collect and retain the runoff from the fuel dispensing area. The spill control manhole shall have a downstream inline valve prior to point of discharge into an approved stormwater drainage system.

Spills and contaminants are treated and contained within the pretreatment device and spill control manhole until authorization is obtained by OLWS to release the substance into an Approved Point of Discharge or dispose of it appropriately offsite. In general, with OLWS approval of the acceptable level of contaminants and release method, the contaminants are allowed to be discharged into the public sanitary sewer system. The shut-off valve shall be located below the outlet elevation, and the manhole shall have a minimum dead storage capacity of 60 cubic feet in volume between the invert elevation (IE) of the inflow pipe and the IE of the discharge pipe for storage of oil, grease, and solids. The tee section shall extend 18 inches below the outlet elevation. The manhole shall be located on private property and accessible for operation and maintenance activities.

### **Shut-Off Valves**

Shut off valves are required to protect the public or private sanitary or stormwater drainage systems from risks that may present a danger or risk to the environment, public health, and safety.

Shut-off valves are required for any of the following situations:

- A. Site or activity areas are exposed to corrosives or oxidizers that can harm stormwater drainage system components (such as, but not limited to, battery acid).
- B. Substances (such as, but not limited to, oil and grease) that do not settle or remain in one location and are capable of being dissolved in or float on water. These substances can spread rapidly into downstream stormwater drainage system and disposal systems, causing widespread impacts and difficult cleanup situations.
- C. Substances that are known to infiltrate through soils and contaminate groundwater.
- D. Traffic pathways that surround fueling pads are considered high use/high-risk areas and will require a valve on the stormwater drainage system. Valves installed on stormwater drainage systems shall be installed downstream of all applicable private SMFs to accommodate spill containment. These valves shall be left open to facilitate stormwater flows during normal conditions, and immediately closed in the event of a spill.
- E. Fueling pads require a valve downstream of the spill control manhole. Valves installed on sanitary sewer systems shall be installed before the public sanitary sewer system tie-in. These valves shall be kept closed and opened upon approval by OLWS. The valve shall be closed immediately after the approved discharge activities are completed.
- F. Shut-off valves shall be located on private property and downstream of all SMFs. All valves shall be installed and maintained per the manufacturer's recommendations and the private maintenance plan approved by OLWS. The

Applicant must also obtain a plumbing permit from the local building authority to install plumbing on private property.

### **Bulk Fuel Terminals**

Bulk fuel terminals, also known as tank farms, require the following:

Secondary containment equal to 110 percent of the product's largest container or 10 percent of the total volume of product stored, whichever is larger.

- A. A separate containment area for all valves, pumps, and coupling areas, with sub-bermed areas either in front of or inside the main containment areas. These sub-bermed areas shall have rain shields and be directed to a public sanitary sewer system with a valve maintained in the closed position to control unauthorized discharges. If no public sanitary sewer is available, drainage shall be directed to a temporary holding facility for proper disposal and may require a WPCF permit from the Water Quality Division of DEQ.
- B. An impervious floor within all containment areas is required to prevent spills from contaminating the groundwater.
- C. Truck loading and off-loading areas shall be covered to prevent spills from entering the public sanitary or stormwater system. To prevent the discharge of spills a shut-off valve is required as identified for fuel dispensing facilities.
- D. Shut-off valves shall be installed for the drainage of the required containment facilities for a tank yard. The valves shall be installed downstream of the primary containment area and kept closed. Valves installed for the drainage of the truck pad and sub-bermed containment areas shall be installed downstream of the SMFs including the spill control manhole.
- E. Approval of a batch discharge from OLWS is required before discharging a containment area into a public sanitary or stormwater system. This approval will determine appropriate disposal methods, identify pretreatment requirements (if applicable), and approval of the discharge. Pretreatment and testing may be required to establish the specific characteristics of the substance to be discharged. Contact OLWS's Environmental Monitoring Division to request authorization for batch discharge.
- F. Underground fuel tanks less than 4,000 gallons in size are subject to additional permitting requirements by DEQ, and tanks larger than 4,000 gallons are referred to the EPA. For technical questions and permitting, call DEQ's North Region Portland office and ask for the Underground Storage Tank Permitting Department. The installations of underground storage tanks are subject to all requirements and permits per the local building authority and OPSC.

### **Additional Requirements**

- A. Track spill control manhole and shut-off valve installations.
- B. Installation, alterations, or removal of above-ground fuel tanks larger than 55 gallons, and any related equipment may be subject to additional building permit

and fire department requirements. For technical questions and permitting, contact the local building authority and OLWS's Development Review Division.

### **2.5.2.02 Above-Ground Storage of Liquid Materials**

These requirements apply to all development where there is any exterior storage of liquid chemicals, food products, waste oils, solvents, process wastewaters, or petroleum products in above-ground containers, in quantities of 50 gallons or more. This includes both permanent storage and temporary storage areas.

#### **Containment**

Liquid materials shall be stored and contained in such a manner that if the container(s) is ruptured, the contents will not discharge, flow, or be washed into a drainageway, public stormwater or sanitary sewer system. A containment device and/or structure for accidental spills shall have capacity to capture a minimum of 110 percent of the product's largest container, or 10 percent of the total volume of product stored, whichever is larger.

Double-walled containers may be exempt from these spill containment requirements.

Quantity thresholds of products that are generally exempt from these spill containment measures include: Janitorial, cleaning, office and stationary supplies packaged for consumer use in containers less than 100 pounds net weight or 15 gallons net volume are exempt from spill containment measures.

Note: This does not include cleaners or solvents used for cleaning machinery or motor vehicle and machine parts.

#### **Cover**

Storage containers (other than tanks) shall be completely covered so rainfall and stormwater runoff cannot come in contact with them. Runoff shall be directed from the cover to a SMF that meets all applicable code requirements.

Covers 10 feet high or less shall have a minimum overhang of 3 feet on each side. The overhang shall be measured relative to the perimeter of the hydraulically isolated activity area.

Covers higher than 10 feet shall have a minimum overhang of 5 feet on each side. The overhang shall be measured relative to the perimeter of the hydraulically isolated activity area.

#### **Pavement (Impervious Surface)**

An impervious surface storage area is required unless otherwise approved by OLWS's Development Review Division. The storage area shall be an impervious surface area and shall meet all applicable zoning and building code requirements. Compactors, containers, and drop boxes shall be located on a level Portland Cement concrete pad, a minimum 4 inches thick, at ground level or other location compatible with the local collection service franchisee's equipment at the time of construction. The pad shall be



designed to discharge stormwater runoff to avoid ponding. Sizing of the impervious areas shall be adequate to cover the area intended for storage.

### **Drainage**

All impervious storage areas shall be hydraulically isolated through grading, berms, or drains, such as:

- A. Covered storage areas. Significant amounts of precipitation are not expected to accumulate in covered storage areas, and drainage facilities are not required for the contained area beneath the cover. If the Applicant elects to install drainage facilities, the drainage from the hydraulically isolated area shall be directed to an approved pretreatment, containment facility and point of discharge.
- B. Uncovered storage areas with containment. Water will accumulate in uncovered storage areas during and after rain. Any contaminated water cannot simply be drained from the area. It must be collected, inspected, and possibly tested at the expense of the Owner before proper disposal can be determined and authorized. Frequent draining may be required during the wet season, which may prove costly. Some type of monitoring may also be needed to determine the characteristics and level of contamination of the stormwater.

All substances and methods discharged to the sanitary sewer shall be authorized by OLWS prior to release. OLWS considers these batch discharges and shall require pretreatment prior to discharge. An industrial discharge permit may be required. Pretreatment requirements shall be set as part of the discharge approval process, based on the types and quantities of material to be discharged. A discharge evaluation shall be performed before connection to a sanitary sewer or stormwater sewer system. Testing may be required to establish characteristics of the wastewater or contaminated stormwater and to verify that local discharge limits are not exceeded. For batch discharge applications and industrial discharge permit requirements, call OLWS's Environmental Monitoring Division.

### **Additional Requirements**

- A. Covered storage areas: A shut-off valve may be required for the covered storage area if the Applicant proposes to install drainage facilities to an approved public sanitary sewer connection. OLWS will make this determination based on the type of material stored and the proposed point of discharge.
- B. Uncovered storage areas: A shut-off valve shall be installed in the storage area so excess stormwater can be drained out of the activity area and directed either to the stormwater drainage facilities (if clean) or into the public sanitary sewer or authorized pretreatment facility (if contaminated). Except when stormwater is being discharged, the valve shall always be kept closed so any spills within the activity area can be effectively contained.
  - a. Tank farms shall follow the criteria established for bulk fuel terminals. Exceptions may be granted, based on the product being stored. Requests for

an exception will require an additional review process and may delay issuance of related building permits.

- b. Storage of reactive, ignitable, or flammable liquids shall comply with the Uniform Fire Code as adopted by the State of Oregon. These source controls are intended to complement, and not conflict with, current fire code requirements. None of these requirements shall exclude or supersede any other requirements in this manual, other OLWS permit requirements, or State and Federal laws pertaining to water quality. Contact OLWS for further information and requirements.

### **2.5.2.03 Recycling and Solid Waste Storage Areas**

These requirements apply to all commercial and industrial development with facilities that store recycling materials and/or solid wastes (both food and non-food wastes). A solid waste storage area is a place where solid waste containers are collectively stored. Solid waste receptacles may include, but are not limited to compactors, containers, carts, barrels, dumpsters, and garbage cans. These requirements also apply to areas used to collect and store refuse or recyclable materials. This applies to multi-family residential sites of five or more units if a shared trash collection area is proposed. However, these requirements do not apply to single-family homes or debris collection areas used for temporary storage of wood pallets or cardboard.

The following design requirements apply for approval of solid waste storage and handling activity areas in OLWS. All receptacles used for storage of solid waste and recyclables (except cardboard) are required to be designed by the manufacturer to fully contain liquid waste if maintained properly and must remain in properly functioning condition throughout their period of use. Per the most current version of the Clackamas County Solid Waste and Recyclable Material collection code, containers used to store cooking oils, grease, or animal renderings for recycling or disposal shall not be located in the principal recyclable materials or solid waste storage areas.

These materials shall be stored in a separate storage area designed for such purpose. Restaurants and other businesses that collect and store oil and grease shall create a separate space under their covered enclosure to store the oil/grease container that does not block access to garbage, food, and recycling containers. Material collection, containers used to store cooking oils, grease, or animal renderings for recycling or disposal shall not be located in the principal recyclable materials or solid waste storage areas. These materials shall be stored in a separate storage area designed for such purpose.

#### **Cover**

Restaurants and other businesses that collect and store oil and grease shall create a separate space in accordance with local zoning and building codes. Additional details on these requirements can be found in the local Solid Waste and Recyclable Material collection code.

A permanent canopy, roof, or awning may be required to cover the solid waste storage area and shall be constructed to cover the activity area so rainfall and stormwater runoff cannot come in contact with the waste materials being stored. The cover shall be sized relative to the perimeter of the hydraulically isolated activity area it is to cover. Runoff shall be directed from the cover to a stormwater disposal point that meets all applicable code requirements.

If the structure is covered, then the Building Drain shall be connected to the public sanitary sewer in accordance with local building and plumbing codes. If the structure is not covered, it cannot be drained into the public sanitary sewer system. Uncovered structures shall drain into the stormwater drainage system with the applicable oil/water separator and cartridge filter water quality treatment.

### **Pavement**

If a paved waste storage area is required. The structure and impervious surface area shall be designed and constructed in accordance with all applicable zoning, building and plumbing codes. The pad shall be designed to discharge stormwater runoff to avoid ponding. Sizing of the paved area shall adequately cover the activity area intended for refuse storage, or the trash compactor(s) and associated equipment.

### **Isolation**

Hydraulic isolation shall be provided for the solid waste storage activity area and shall be designed to prevent uncontaminated stormwater runoff from entering the area and carrying pollutants away. Runoff occurring outside the hydraulically isolated area shall be directed to a stormwater disposal point that meets all applicable code requirements. This can be achieved by reverse grading at the perimeter of an activity area, perimeter curbing or berming, or the use of area drains to collect and divert runoff.

### **Drainage**

The paved area under the cover shall be hydraulically isolated, meaning no stormwater draining into or liquids draining out of the covered storage area. Hydraulic isolation may include installation of a berm or grading that prevents uncontaminated stormwater from running into the waste storage area and ensures that any fluid under the enclosure drains to the sanitary system. An oil/water separator may be required as pretreatment before discharging to the sanitary system, per Section 2.5.1.

### **Non-gravity Option**

Activity areas that do not have gravity sanitary sewer service may be allowed to install a pressurized system in accordance with local building and plumbing codes. With these types of installations, the following items shall be provided at the time of building permit application:

- A. Verification or evidence that gravity service cannot be obtained.
- B. Details of an electronic sump pump system equipped with a float switch.
- C. OLWS approval.

Pressurized system installations are considered “permanent equipment” and deemed the Owner’s liability in the event of system failure or if the property becomes vacated.

The local building and plumbing codes authorities will review all sump pump or sewage ejector installations for compliance with the UPC and Oregon State Plumbing Specialty Code.

#### **2.5.2.04 Exterior Storage of Bulk Materials**

These requirements apply to developments that stockpile or store materials in outdoor containers that may erode or have negative stormwater impacts. The materials are separated into the following three categories, based on risk assessments for each material stored: high-risk, low-risk, and exempt materials.

These include, but are not limited to, the types found in Table 2. Materials with any of the following characteristics are exempt from these requirements:

- A. Have no measurable solubility or mobility in water and no hazardous, toxic, or flammable properties.
- B. Exist in a gaseous form at ambient temperature.
- C. Are contained in a manner that prevents contact with stormwater (excluding pesticides and fertilizers).

#### **Cover**

Low-risk materials shall be covered with a temporary plastic film or sheeting at a minimum.

High-risk materials shall be permanently covered with a canopy or roof to prevent stormwater contact and minimize the quantity of rainfall entering the storage area. Runoff shall be directed from the cover to an approved stormwater disposal point that meets all applicable code requirements.

*Table 2. Stormwater Impacts of General Material Types*

|   |
|---|
| <p><b>High Risk Materials</b></p> <ul style="list-style-type: none"><li>• Recycling materials with potential effluent (including mercury containing items)</li><li>• Corrosive materials (e.g., lead-acid batteries)</li><li>• Storage and processing of food items</li><li>• Chalk/gypsum products</li><li>• Feedstock/grain</li><li>• Material by-products with potential effluent</li><li>• Fertilizer</li><li>• Pesticides</li><li>• Oily or otherwise contaminated vehicle/equipment parts</li><li>• Lime/lye/soda ash</li><li>• Animal/human wastes</li></ul> |
| <p><b>Low Risk Materials</b></p> <ul style="list-style-type: none"><li>• Recycling materials without potential effluent</li><li>• Used tires</li><li>• Non-oily scrap or salvage</li><li>• Treated lumber</li></ul>   |

- Metal
- Sawdust/bark chips
- Sand/dirt/soil (including contaminated soil piles)
- Material by-products without potential effluent
- Unwashed gravel/rock
- Compost
- Asphalt
- Non-leaking vehicles in stages of disassembly

**Exempt Materials**

- Rock
- Finished untreated lumber
- Rubber and plastic products (hoses, gaskets, pipe, etc.)
- Clean concrete products (blocks, pipe, etc.)
- Glass products (new, non-recycled)
- Inert products

Covers 10 feet high or less shall have a minimum overhang of 3 feet on each side. The overhang shall be measured relative to the perimeter of the hydraulically isolated activity area.

Covers higher than 10 feet shall have a minimum overhang of 5 feet on each side. The overhang shall be measured relative to the perimeter of the hydraulically isolated activity area.

**Pavement**

Low-risk material storage areas are not required to have an impermeable surface.

High-risk material storage areas shall be impervious beneath the structural cover. Sizing of the impervious surface area shall adequately cover the activity area intended for storage.

**Drainage**

Low-risk material storage areas are typically allowed in areas served by standard SMFs. However, all erodible materials being stored must be protected from rainfall and stormwater runoff.

If materials are erodible, a structural containment barrier shall be placed on at least three sides of every stockpile. The barrier shall be tall enough to prevent the contained and uncontaminated area from mixing stormwater runoff into the storage area with the stored materials as a result of being blown or washed away. If the area under the stockpile is paved, the barrier can be constructed of asphalt berms, concrete curbing, or retaining walls. If the area under the stockpile is unpaved, sunken retaining walls or ecology blocks can be used. The Applicant shall clearly identify the method of containment on the building and/or site plans.

For high-risk material storage areas, the paved area beneath the structural cover shall be hydraulically isolated through grading, structural containment berms or walls, or perimeter drains to prevent uncontaminated stormwater from running onto the area and carrying pollutants away. If significant amounts of precipitation are not expected to

accumulate in covered storage areas, drainage facilities are not required for the contained area beneath the cover. If the Applicant elects to install drainage facilities, the drainage from the hydraulically isolated area shall be pretreated and connected to a point of discharge approved by OLWS. In such a case, an evaluation will be done to determine if an NPDES Discharge permit is required.

#### **Additional Requirements**

- A. Storage of pesticides and fertilizers may need to comply with specific regulations outlined by DEQ. For answers to technical questions, call DEQ's Northwest Region Portland office.
- B. A sampling manhole or other suitable stormwater monitoring access point may be required to monitor stormwater runoff from the storage area. This may apply to certain types of storage activities and materials if an alternative source control is proposed. OLWS's Development Review Division will review for applicability of this requirement.
- C. Hazardous materials signage shall be provided at the storage area where hazardous materials or other materials of concern are stored. Signage shall be located so it is plainly visible from all storage activity areas. More than one sign may be needed to accommodate large storage areas.
- D. A shut-off valve may be required for the structurally covered storage area if the Applicant elects to install drainage facilities and discharge into a sanitary system. OLWS's Development Review Division will make this determination based on the type of material stored and the proposed system receiving the discharge.

#### **2.5.2.05 Material Transfer Areas/Loading Docks**

These requirements apply to all developments proposing the installation of new material transfer areas, or structural alterations to existing material transfer areas (e.g., access ramp regrading, leveler installations).

The requirements apply to all material transfer areas, including loading/unloading docks, bay doors, and any other building access point(s) with the following characteristics:

- A. The area is designed (size, width, etc.) to accommodate a truck or trailer being backed up to or into it; and,
- B. The area is expected to be used specifically to receive or distribute materials to and from trucks or trailers.

The requirements may not apply to areas that are used only for mid-sized to small-sized passenger vehicles and that are restricted (by lease agreements or other regulatory requirements) to storing, transporting, or using materials that are classified as domestic use: Primary educational facilities (elementary, middle, or high schools), buildings used for temporary storage (a lease agreement will need to be provided), and churches.

Contact OLWS's Development Review Division for help in determining if requirements apply.

### **Pavement**

An impervious surface area such as asphalt or concrete shall be placed underneath and around the loading and unloading activity area and shall meet all applicable building code requirements. This will reduce the potential for soil contamination with potential impacts on groundwater and will help control any acute or chronic release of materials present in these areas.

### **Isolation**

The first 3 feet of the paved/covered area of a loading dock, measured from the building or dock face, shall be hydraulically isolated through grading, berms, or drains to prevent uncontaminated stormwater from running onto the area and carrying pollutants away.

Bay doors and other interior transfer areas shall be designed so that stormwater runoff does not enter the building. This can be accomplished by grading or drains.

### **Drainage**

Drainage from the hydraulically isolated, covered loading dock area shall be directed to a pretreatment facility and then the sanitary sewer. Surrounding runoff and drainage from the access ramp shall be directed away from the hydraulically isolated area to a SMF that meets all applicable requirements of this manual.

Areas which cannot gravity discharge may be allowed to install a pressurized system. With these types of installations, the following items shall be provided at the time of building permit application:

- A. Proof that a gravity system cannot be obtained.
- B. Details of an electronic sump pump system equipped with a float switch.
- C. A point of discharge approved by OLWS.

Pressurized system installations are considered "permanent equipment" and deemed the Owner's liability in the event of system failure or if the property becomes vacated.

The local building authority will review all sump pump or sewage ejector installations for compliance with the UPC and OPSC. OLWS's Development Review Division will review the pressurized systems for compliance with the Standards.

**Bay Doors and Other Interior Transfer Areas.** Because interior material transfer areas are not expected to accumulate precipitation, installation of floor drains is not required or recommended. It is preferable to handle these areas with a dry mop or absorbent material. If interior floor drains are installed, they shall be plumbed to an approved pretreatment facility and discharge into the public sanitary sewer.

### **Shut-off Valves**

A shut-off valve downstream of the transfer area may be required to prevent spills and contamination from leaving this area. OLWS's Development Review Division will make

this determination, based on the type of material being transferred, pretreatment facility and the Approved Point of Discharge.

Shut-off valves are required to protect health, safety and the environment from spills and substances that may provide a risk. Shut-off valves are required for any of the following situations:

- A. Site activity areas that are exposed to corrosives or oxidizers that can harm stormwater drainage system components (such as battery acid).
- B. Substances (such as oil and grease) that do not settle or remain in one location and are capable of being dissolved in or float on top of water. These substances can spread rapidly into downstream systems, causing widespread impacts and difficult clean-up situations.
- C. Substances that are known to infiltrate through soils and contaminate groundwater.

Valves located in material transfer areas are typically left open to facilitate drainage during normal conditions, and immediately closed in the event of a spill.

Prior to transfer activities of harmful substances, the valves shall be closed and reopened only after the transfer is complete. The shut-off valves must be located on private property and downstream of the exposed area's collection system.

All valves shall be installed and maintained in accordance with manufacturer specifications. For additional information about installation of shut-off valves contact the local building authority.

#### **Additional Requirements**

Bay doors and other interior transfer areas shall provide a 10-foot "no obstruction zone" beyond the entrance within the building. This will allow the transfer of materials to occur with the truck or trailer end placed at least 5 feet inside the building, with an additional staging area of 5 feet beyond that. The "no obstruction" zone shall be clearly identified on the site plan at the time of the building permit application and shall be painted at the facility with bright or fluorescent floor paint.

#### **2.5.2.06 Equipment and/or Vehicle Washing Facilities**

These requirements apply to all development within designated equipment, vehicle washing or cleaning areas. This includes smaller activity areas, such as wheel-washing stations. Residential sites are exempt.

#### **Cover**

The washing area shall be covered with a permanent canopy or roof so precipitation cannot come in contact with the washing activity area. Precipitation shall be directed from the cover to a SMF that meets all applicable code requirements.

- A. Covers 10 feet high or less shall have a minimum overhang of 3 feet on each side. The overhang shall be measured relative to the perimeter of the hydraulically isolated washing activity area it is to cover.



- B. Covers higher than 10 feet shall have a minimum overhang of 5 feet on each side. The overhang shall be measured relative to the perimeter of the hydraulically isolated washing activity area it is to cover.

**Pavement**

The wash pad area shall be impervious surface such as asphalt or concrete placed under and around the washing activity area and shall meet all applicable building code requirements. Sizing of the paved area shall adequately cover the activity area, including the placement of the vehicle or piece of equipment to be cleaned.

**Drainage**

The paved area beneath the cover shall be hydraulically isolated through grading, berms, or drains to prevent uncontaminated stormwater from running onto the area and carrying pollutants away. Drainage from the hydraulically isolated area shall be directed to a pretreatment facility and then the sanitary sewer. If connected to the public sanitary sewer, and, depending on the washing compounds used (i.e., brighteners), an industrial discharge permit to the public sanitary sewer system may be required. For further questions, contact the Development Review Division. Surrounding runoff shall be directed away from the hydraulically isolated washing pad to a SMF that meets all applicable requirements.

**Oil Controls**

All vehicle and equipment washing activities shall be equipped with an approved oil/water separator system. The system shall comply with the public sanitary sewer discharge limits. For discharge requirements and limitations to the public sanitary sewer system contact OLWS's Environmental Monitoring Division.

For washing areas protected with a cover or located inside a structure, the following design criteria apply to oil/water separators discharging a public sanitary sewer system:

- A. Baffled oil/water separators and spill control (SC-type) separators shall not be allowed for use with equipment and/or vehicle washing applications. Note: Activities and processes of a washing facility change over time, and the introduction of heat and surfactants may occur.
- B. Coalescing plate separators shall be designed to achieve a 100-ppm non-polar oil and grease limit in the effluent from the peak flow generated by the washing activity. Testing information must be submitted by the manufacturer of the unit that supports the 100-ppm effluent standard at the calculated flow rate.
  - a. The minimum design flow rate shall be 10 gallons per minute which is the estimated flow from a 5/8-inch hose.
  - b. For specially designed washing units, check the vendor specifications for maximum flow rates.
- C. Any pumping devices shall be installed downstream of the separator and pretreatment facility to prevent oil emulsification.

- D. Separator details must be shown on the building plans submitted at the time of building permit application and shall match manufacturer specifications and details, including the unit flow rate, effluent water quality, and maximum process flow rate.
- E. All separators shall be maintained per the manufacturer specifications and OLWS approved maintenance plan.

Onsite wash recycling systems may be used for oil control as long as they can meet effluent discharge limits for the public sanitary sewer system. A detail of the wash recycling system and vendor specifications identifying effluent efficiencies shall be submitted as part of the building plans at the time of the building permit application.

#### **2.5.2.07 Equipment and/or Vehicle Repair Facilities**

These requirements apply to all development within designated equipment or vehicle repair including areas conducting body work.

##### **Cover**

Repair areas shall be located indoors so precipitation cannot come in contact with the repair area. Precipitation shall be directed from the repair facility roof to a SMF that meets all applicable OLWS requirements.

##### **Floors**

The floor shall be impervious material such as concrete.

##### **Drainage**

The exterior of the repair area shall be hydraulically isolated through grading, berms, or drains to prevent uncontaminated stormwater from running onto the area and carrying pollutants away. Runoff shall be directed away from the hydraulically isolated repair area to a SMF that meets all applicable requirements.

##### **Storage**

Interior: Chemicals used for cleaning machinery or motor vehicle and machine parts (including, but not limited to, lubricants, used fluids, solvents, cleaners, etc.) of any quantity must be stored in or on secondary containment structures.

Exterior: Chemicals and materials must be stored in a manner consistent with the requirements set forth in Section 2.5.

##### **Oil Controls**

All vehicle and equipment repair areas with floor drains and/or shop sinks must have an approved oil/water separator system and comply with OLWS's sanitary sewer discharge standards. Details on oil/water separator design criteria are in Section 2.5.

#### **2.5.2.08 Land with Suspected or Known Contamination**

These requirements apply to all development projects that disturb property at risk, suspected, or known to contain pollutants in the soil or groundwater. This includes development that is surrounded by properties found to have trace pollutants. These

requirements will also be applied to any property that is seeking to make a new connection to a public stormwater system or drainageway from a property that is at risk, suspected, or known to contain pollutants in the soil or groundwater. To avoid confusion with references to water quality pollutants throughout this manual, this section refers to pollutants as contaminants and/or contamination.

Because of local, State, and Federal regulations, special handling and management of soils, groundwater, and surface drainage may be necessary. As a result of these regulations, sites with suspected or known contamination require a more detailed review process that may delay issuance of related site plan and building permit approvals. Applicants are advised to contact the Development Review Division early in the planning process (before plan submittal) if they are aware or suspect the site has contaminants or is adjacent to a contaminated site.

To research contaminant information, refer to DEQ's Environmental Cleanup Site Information database.

- A. If records indicate there is a potential of contamination on the site, the Applicant must contact DEQ prior to pre- and post-construction activities. For technical questions related to site contamination and clean-up, contact the Land Quality Division of DEQ.
- B. All regulatory divisions or departments of DEQ referenced in this section can be reached by calling DEQ's Northwest Region Portland Office.
- C. If a Phase 1 DEQ Site Assessment was required, the report will be submitted to OLWS for review.
- D. If contamination is discovered subsequent to site plan approval the Owner shall immediately take steps to protect health, safety and the environment and contact OLWS and DEQ. Plan approval is suspended until the contamination issues are resolved.

Contaminants have the potential to become entrained and transported through exposure to construction activities and post-construction design elements of a development. The requirements in this section apply to:

- A. Excavation and stockpiling of contaminated soils (soil management)
- B. Disposal or re-use facilities related to groundwater, foundation or footing drains, interior floor drains in basements or sub-grade structures, construction dewatering, and surface stormwater treatment and stormwater drainage systems.

Stormwater discharges from sites suspected of contamination, whether proposed as a temporary construction connection or as permanent connection to any public storm, sanitary sewer system or drainageway, will require a special authorization from OLWS and Environmental Monitoring Division. After reviewing the proposal and a characterization of the contaminants on the site, OLWS and/or Environmental Monitoring Division will make one of the following decisions:

- A. Approve discharges to the public stormwater and/or sanitary sewer system with restrictions such as described in these pages or as is necessary given the nature of the discharge.
- B. Require the Applicant to obtain an NPDES permit from DEQ for the anticipated discharge prior to connection to a public system.
- C. Require the Applicant to obtain an OLWS Industrial Pretreatment Permit.
- D. Deny the request to discharge to the public stormwater and/or sanitary sewer system.
- E. Allow unrestricted connection to the public stormwater and/or sanitary sewer system, with an approved monitoring/testing structure.

Contaminants, media, and site conditions are unique to each parcel of land. Sites at risk for contamination shall therefore be reviewed on a case-by-case basis.

### **Soil Management**

Stockpiles of contaminated soils shall be covered with temporary plastic film or sheeting to prevent stormwater from contacting them.

Stockpile perimeters shall have a containment barrier on all four sides of every stockpile to prevent stormwater run-on and material run-off. Barriers can consist of concrete curbing, silt fencing, or other berm materials, depending on the activity, size, and resources available.

Areas under stockpiles of contaminated soils are not required to be paved. However, an impervious layer shall be placed beneath the stockpile to protect uncontaminated areas from potential leachate.

### **Construction Dewatering**

For technical assistance on obtaining a batch discharge approval for construction dewatering activities, contact OLWS's Development Review Division. The following requirements apply:

- A. Construction dewatering discharges from contaminated sites to OLWS's stormwater system are prohibited. Upon approval by OLWS, these waste streams may be discharged to the sanitary sewer if the discharge meets all standards detailed in Section 2.5.1.03.
- B. Laboratory analysis reports with data for all pollutants of concern will be required.
- C. Installation of required pretreatment technology, an approved sampling point, and/or a meter may be required by OLWS prior to any discharge to the sanitary sewer is permitted.
- D. Contact OLWS for further information on discharging water to the sanitary sewer system.

- E. If onsite infiltration is the proposed method for disposal, authorizations are required from OLWS and the Land and Water Quality Divisions of DEQ. Private infiltration facilities for construction dewatering shall be located and maintained on private property outside the Public ROW.
- F. If a public sanitary system is the proposed method of disposal, authorizations are required from OLWS including the Environmental Monitoring Division and will be allowed only if extensive pretreatment is implemented and the discharge is approved by OLWS. All groundwater, stormwater, and surface water discharges to a sanitary sewer system shall meet local discharge limits and will be subject to all fees and discharge volume charges.
- G. If a Public Stormwater System is the proposed method of disposal, evaluations of discharge to the public stormwater system will be based on whether discharges meet, or can be pretreated to meet, requirements of OLWS, NPDES Discharge Permit or other State and Federal regulations for the receiving drainageway.
- H. If a drainageway is the proposed method for disposal, authorizations are required from OLWS, Land and Water Quality Divisions of DEQ.

**Post-Construction Surface Drainage Systems**

If onsite infiltration is the proposed method for disposal, authorizations are required from OLWS, Land Quality, and Water Quality Divisions of DEQ. Private infiltration facilities shall be located and maintained on private property, outside the Public ROW.

If a drainageway is the proposed method for disposal, authorizations are required from OLWS, the Army Corps of Engineers (USACE), and both the Land Quality and Water Quality Divisions of DEQ.

If an offsite public stormwater or sanitary sewer system is the proposed method for disposal, authorization is required from OLWS. Evaluations for discharges from sites with suspected contamination will be based on the following:

- A. Surface drainage systems that are not exposed to industrial activities, contaminated soils, or subsurface discharges are not assumed to contain contaminants and do not pose a threat to public infrastructure. All discharges to a public sanitary sewer system will require an additional review and approval process.
- B. A permanent monitoring and testing point may be required to ensure compliance with discharge regulations. If monitoring is necessary, a permanent structure (such as a sampling manhole or flow-through vault) shall be constructed per OLWS Standards and installed on the discharge line.

**Laboratory Analysis Reports**

Laboratory analysis reports are required to identify the characteristics and levels of contamination in the soils and groundwater of a site.

OLWS will determine the applicable process to review the laboratory reports to determine regulatory authority and requirements. Testing and analysis are highly

recommended prior to submitting the site plan. DEQ permitting and/or review may be required if contaminants are found and the levels of contamination appear to exceed OLWS discharge regulations. This may delay issuance of the site plans and related building permits.

Laboratory analysis reports shall include the following information:

- A. Analysis reports shall identify the elevation of the seasonal water table and identify the depth of any perched water aquifers.
- B. Analysis reports shall identify the method of laboratory testing, the detection level and analytical method used for detection, and the depth of any found contaminants in the soils.
- C. Minimum test parameters for baseline contaminants shall include metals (arsenic, cadmium, chromium, copper, lead, mercury, molybdenum, nickel, selenium, silver, and zinc); total petroleum hydrocarbons; and benzene, toluene, ethyl benzene and xylene.
- D. Test parameters may be required to include other contaminants identified through historical data, research, and environmental assessments.

#### **Additional Requirements**

Typical structural controls that would need OLWS approval include containment areas, shut-off valves, oil/water separators and pretreatment facilities. If an Applicant requests an alternative or exception to any of the source controls identified in this section, the Applicant shall engage with OLWS staff. These types of requests require an additional review process and may delay issuance of the site plans and related building or development permits.

#### **2.5.2.09 Covered Vehicle Parking Areas for Commercial and Industrial Uses**

These requirements apply to all development with a covered vehicle parking area, except single-family and duplex residential sites. Projects that add a cover to an existing parking structure are not required to meet these requirements unless the project expands or replaces existing impervious surfaces.

- A. Stormwater runoff from the top floor of a multi-level parking structure shall be directed to an SMF and Approved Point of Discharge that meets all requirements of these Standards.
- B. Significant amounts of precipitation are not expected to accumulate in covered vehicle parking areas, and drainage facilities are not required for the lower floors. If the Applicant elects to install drainage facilities, the drainage from the lower floors of a multi-level parking structure shall be directed to the public sanitary sewer system. Prior to discharge all applicable pretreatment and/or oil water separator requirements shall be met.

- C. The surrounding uncovered portions of the site shall be designed so precipitation and stormwater runoff does not enter the covered parking areas. This can be accomplished through grading and/or drains.
- D. Single-level covers (canopies, overhangs, and carports) are exempt from the requirements of this section.

### **2.5.2.10 Industrial and Commercial High Traffic Areas**

These requirements apply to all new development with vehicle parking areas for developments zoned industrial or commercial with high-traffic volumes. High-traffic volumes are defined as an average daily traffic of 2,500 vehicles, consistent with DEQ’s Industrial Stormwater Best Management Practices Manual (February 2013).

Industrial and commercial high-traffic areas with a drainage area of over 10,000 sf directed to a single shall have an adequate oil control facility located upstream of the SMF. Parking areas of over 10,000 sf that are divided into drainage areas of less than 10,000 sf do not require this pretreatment.

#### **Oil Controls**

An oil/water separator with coalescing plates shall be installed between the surface drainage catchment structure and the stormwater management treatment facility. The purpose of the device is to treat and prevent hydrocarbons from entering the SMF. This device shall be maintained per the manufacturer’s specifications and the approved operations and maintenance plan.

Coalescing plate separators shall be designed to achieve a 100-ppm non-polar oil and grease limit in the effluent from the peak flow generated by the washing activity. Testing information must be submitted by the manufacturer of the unit that supports the 100-ppm effluent standard at the calculated flow rate.

Flow rates will be determined by the drainage area served by the device. The device will be sized to treat the Water Quality Design Storm as specified in Section 2.6.

For Proprietary Stormwater Treatment Devices (see Section 2.6.5.10), check the vendor specifications for design flow rates.

Oil controls and pretreatment facility details must be shown on the building plans submitted at the time of building permit application and shall match manufacturer specifications and details, including the unit flow rate, effluent water quality, and maximum process flow rate.

All oil controls and pretreatment facilities shall be maintained per the manufacturer specifications and the approved operation and maintenance plan.

## **2.6 STORMWATER MANAGEMENT FACILITY DESIGN**

---

SMFs include a variety of methods to mitigate stormwater runoff and remove pollutants from stormwater, including detention, infiltration/retention, sedimentation, filtration, plant uptake, ion exchange, adsorption, and bacterial decomposition. Infiltration is the preferred method to

address stormwater runoff for water quality and flow control requirements. In some cases, using a combination of SMFs may be the most effective strategy for removal of specific pollutants of concern in designated high-risk areas.

This section describes the methods and criteria for designing SMFs to meet water quality and flow control performance standards. Additional structural source controls may be required for certain types of development categorized as high risk for pollutants as described in Section 2.5.

OLWS's Stormwater Standards guide the design of Stormwater Management Plans for new development and redevelopment projects. Site-specific Stormwater Management Plans are most effective when developed early in the site planning process. Strategies for meeting the requirements in these standards depend on several site factors, including soil infiltration capacity, available infrastructure, proposed development plans, and downstream conveyance. The plan review and approval requirements are specific to each jurisdiction and may vary from one application, submittal, and building permit to another. To obtain further information on a specific plan review or permit process, contact OLWS.

## **2.6.1 Stormwater Management Performance Standards**

Applicants of projects subject to stormwater review must demonstrate that the proposed project will include SMFs that meet water quality and flow control performance standards.

### **2.6.1.01 Water Quality Performance Standard**

SMFs shall be designed to capture and treat 80 percent of the average annual runoff volume, to the maximum extent practicable with the goal of 80 percent total suspended solids removal. In this context, "maximum extent practicable" means less-effective treatment may not be substituted when it is practicable to provide more effective treatment. Based on local rainfall frequency and intensity, the required treatment volume equates to a Water Quality Design Storm of 1.0 inch over 24 hours. SMFs for water quality shall be designed in conformance with the design guidelines in this section.

Hydrodynamic separators, when used as a sole method of stormwater treatment, do not meet the "maximum extent practicable" requirement for stormwater treatment effectiveness with regard to these Standards.

### **2.6.1.02 Flow Control Performance Standard**

Flow control facilities shall be designed so that the duration of peak flow rates from Post-Development Conditions shall be less than or equal to the duration of peak flow rates from pre-development conditions for all peak flows between 42 percent of the 2-year peak flow rate up to the 10-year peak flow rate. A hydrologic/hydraulic analytical model capable of performing a continuous simulation of peak flow rates from local long-term rainfall data must be used to determine the peak flow rates, recurrence intervals, and durations. SMFs for flow control shall be designed in conformance with the design guidelines in Section 2.6.



Flow control is not required for projects that discharge directly to the Willamette River, provided that all of the following conditions are met:

- A. The project site is drained by a stormwater drainage system that is composed entirely of man-made conveyance elements (e.g., pipes, culverts, ditches, outfall protection, etc.) and the stormwater drainage system extends to the ordinary high-water line of the exempt water body.
- B. The entire length of the stormwater drainage system between the project site and the exempt receiving water shall have sufficient hydraulic capacity to convey discharge from the proposed development of the site and the existing development condition from the remaining drainage area contributing to the stormwater drainage system for the 25-year storm event, based on the conveyance of the design storm as outlined in Section 2.7.3.
- C. Any erodible elements of the man-made stormwater drainage system must be adequately stabilized to prevent erosion under the conditions noted above.
- D. The constructed stormwater drainage system does not result in an inter-basin transfer of runoff, as determined by OLWS.

Projects that are exempt from flow control are still subject to the other requirements outlined in these standards, including requirements to provide erosion and sediment control, water quality treatment, stormwater drainage systems, downstream stormwater drainage system analysis and applicable source controls.

#### **2.6.1.03 Emergency Overflow Pathway**

For all projects with SMFs, an overland emergency overflow pathway must be identified and/or designed that allows runoff from large storm events to discharge without risk of injury or property damage. The emergency overflow pathway must be incorporated into the design to show how flow will escape from the site during rainfall events larger than the design storm and/or from failure of the primary stormwater drainage system. If a Stormwater Drainage System is used as a component to convey the emergency overflow pathway, then the structure(s) and system shall be designed to convey the 100-year Design Storm.

The Applicant shall identify the proposed 100-year emergency overflow pathway. If downstream properties are impacted by the 100-year storm event, then the Applicant shall provide additional flow control or secondary SMFs to mitigate the potential impact.

#### **2.6.1.04 Fee In Lieu**

When a proposed development is unable to meet the flow control or water quality performance standards, OLWS may allow Applicants to pay a fee in lieu of stormwater management improvements. In such a case, the fee shall be based on a proportional cost for OLWS to construct an equivalent SMF including costs for land acquisition, design, construction, maintenance, and administration.

The financial viability of designing and constructing onsite or offsite SMFs is not a justification to use the fee in lieu program. Applicants must demonstrate that the proposed development site has one or more physical limitations that prevent the installation of onsite SMFs, and that offsite or regional facilities are not a feasible alternative. All projects should meet the downstream stormwater drainage system capacity requirements, and provide an emergency overflow pathway, as needed.

## **2.6.2 Stormwater Management Facility Sizing Methods**

This section explains the methods accepted by OLWS for determining the appropriate size and configuration of SMFs to achieve the performance standards.

A Stormwater Report that meets the submittal requirements of Appendix A must accompany the engineered stormwater plans to demonstrate and document the design, including sizing methods and calculations.

### **2.6.2.01 Infiltration**

Infiltration is the required strategy to achieve the stormwater management performance standards unless it can be demonstrated that infiltration is not possible. When a SMF is designed to fully infiltrate the 10-year, 24-hour Design Storm, the facility is assumed to meet the flow control performance standard without further analysis. Such facilities provide onsite stormwater retention for most rainfall conditions and should only result in partial downstream discharge during events larger than a 10-year storm. When site conditions do not allow infiltration of the full 10-year, 24-hour Design Storm, infiltration shall still be incorporated into the flow control facility design to reduce the volume of discharge released from the site unless it can be proven that infiltration is not possible. Flow control facilities designed with partial infiltration should include an underdrain, control structure, and overflow system to manage the release rates from the facility. Whether or not infiltration is incorporated into the design, release rates from the facility must meet the flow control performance standard in Section 2.6.1.02.

When a rain garden, planter, swale, or pond is designed to fully infiltrate the 10-year, 24-hour Design Storm, the facility is also assumed to meet the water quality performance standard, without further analysis. UIC facilities, such as drywells, infiltration trenches, and infiltration chambers may require upstream water quality treatment to meet the water quality performance standards. Refer to the individual facility design requirements in Section 2.6.5 to determine which infiltration facilities can be used to provide upstream water quality treatment for UICs. When a UIC facility is designed to infiltrate the 10-year 24-hour Design Storm, the Applicant is responsible for demonstrating the proposed UICs will be rule authorized under Oregon Administrative Rules (OAR) 340-44-008 or will obtain an DEQ-issued UIC Permit.

The Applicant shall conduct infiltration testing and establish a design infiltration rate as described in this section. Infiltration testing is required as part of obtaining the Service Provider Letter.

Infiltration may be limited where any of the following conditions exist:

- A. Infiltration rates of less than ½-inch per hour.
- B. Sites that include steep slopes (>25 percent) and/or geologic hazard zone designation (Subsection 1002.01, Hillsides of the Clackamas County Zoning and Development Ordinance). A geotechnical engineering or geologist report and OLWS approval is required for infiltration facilities located on moderate slopes of 10 to 25 percent.
- C. Sites in areas of seasonal high groundwater table. Sites with jurisdictional wetlands or FEMA floodplains may be required to perform a seasonal high groundwater table assessment to determine that the seasonal groundwater table is at least 12 inches below the bottom of proposed non-infiltrating stormwater facilities.
- D. Sites within the 2-year time of travel to irrigation or drinking water wells or within the 500-foot horizontal setback from irrigation or drinking water wells are not suitable for UICs, such as drywells or infiltration trenches or galleries. However, green infrastructure facilities that provide water quality treatment in conjunction with infiltration, such as rain gardens, planters, and bioinfiltration swales, may still be used within water pollution control facility (WPCF) permit setback distances.
- E. Sites where SMFs would be located on new or existing structural fill material.
- F. Sites that have contaminated soils must be evaluated by the DEQ and/or the EPA to determine if areas on the property are suitable for infiltration without the risk of mobilizing contaminants in the soil or groundwater. Documentation showing contamination assessment and determination must be submitted to OLWS at the time of application.
- G. There is a conflict with required source controls for high-risk sites (see Section 2.5).

For sites with limiting conditions, Applicants should document the infiltration limitations and design SMFs that do not use infiltration exclusively to meet the performance standards. Infiltration testing may still be required to document select limitations.

Sites without limiting conditions have the potential to use infiltration as part of the stormwater management strategy. Applicants shall conduct infiltration testing and establish a design infiltration rate for potential SMFs. Infiltration, even at slow rates, has the potential to retain stormwater at the source, recharge groundwater, and reduce offsite flows. Incorporating infiltration into SMF design can also reduce the footprint of required SMFs.

Regardless of the tested infiltration rate of the soils on the site, Applicants must demonstrate that SMFs will meet the performance standards for water quality treatment and flow control detailed in Section 2.6.

Infiltration testing is required to determine the suitability to retain the stormwater runoff.

**Infiltration Testing to Establish Site Characteristics and to Assess Stormwater Facility Viability**

Infiltration testing should be conducted to establish site conditions and soil strata. Infiltration testing can identify ideal locations for SMFs or to identify where site constraints exist.

**Required Infiltration Tests**

The type and number of required infiltration tests depends on the size and type of proposed development (see Table 3 and Table 4). Infiltration testing shall be conducted according to the specifications in Appendix A, or using an equivalent method approved by OLWS. When a confining layer, or soil with a greater percentage of fines is observed during the subsurface investigation to be within 4 feet of the bottom of the planned SMF, the testing should be conducted within the confining layer

*Table 3. Types of Infiltration Tests*

| Development Size   | Test Type                        | Number of Tests   |
|--|----------------------------------|---|
| Development less than 10,000 square feet of impervious area                | Basic Method                     | One test at the location and depth of each proposed SMF |
| Development equal to or greater than 10,000 square feet of impervious area | Professional / Engineered Method | See Table 4.  |

*Table 4. Number of Professional Method Infiltration Tests*

| Type of Development   | Location of Infiltration Test                    | Minimum Number of Infiltration Tests | Maximum Number of Infiltration Tests   |
|---|--|--------------------------------------|--|
| Single Family and Partitions  | At the location and depth of the proposed SMF(s) | One test per SMF                     | One test per SMF   |
| Subdivisions  | At location and depth of the proposed SMF(s)     | One test per SMF                     | If more than five SMFs are proposed, OLWS may accept a recommended infiltration rate from a Geotechnical Engineer based on the consistency of the soil classification(s) throughout the site, unless otherwise permitted by OLWS |
| Non-single family residential (e.g., multi-family, commercial, industrial, and all other types) | At location and depth of the proposed SMF(s)     | One test per SMF                     | If more than five SMFs are proposed, OLWS may accept a recommended infiltration rate from a Geotechnical Engineer based on the consistency of the soil classification(s) throughout the site, unless otherwise permitted by OLWS |

### **Design Infiltration Rate**

When feasible, infiltration is the preferred strategy to satisfy the flow control performance standard. The design infiltration rate shall be determined by the Developer's Engineer conducting the infiltration test. A minimum correction factor of 2 shall be applied to the field-tested infiltration rates to determine the design infiltration rate for SMF design.

The design infiltration rate after applying the safety factor shall not exceed 100 in/hr for non-vegetative facilities, such as drywells or infiltration chambers. Vegetated facilities with growing media shall be designed at a maximum infiltration rate of 6.0 in/hr through the growing media.

SMFs shall be designed with an infiltration component, unless otherwise stipulated by the design professional. If the SMF cannot be designed to fully infiltrate the 10-year storm event, then an underdrain and outflow will be required to safely convey the discharge from the SMF to an approved discharge point. If the proposed facility does not have an approved discharge point, then it must be designed to fully infiltrate the 25-year storm event as required by OLWS.

#### **2.6.2.02 Water Quality Facility Sizing**

Water quality SMFs shall be sized to capture and treat 80 percent of the average annual stormwater runoff with the goal of 80 percent total suspended solids removal. This is equivalent to treating runoff from the first 1.0 inch of an individual 24-hour storm event.

The water quality design volume or flow rate shall be determined through one of the following methods:

- A. The water quality design volume for volume based SMFs (constructed wetlands, ponds, planters, rain gardens, and bioinfiltration swales) shall be calculated as the total runoff volume from a storm with 1.0 inch of precipitation. Volume analysis may be performed using a hydrograph analysis program or spreadsheet tools. (Refer to Section 2.7 and Appendix D for design limitations and calculation references when using the Santa Barbara Urban Hydrograph [SBUH], Technical Release 55 (TR-55), or SWMM method for sizing water quality treatment.) The City of Portland's Stormwater Management Manual Presumptive Approach Calculator is not approved for use to meet OLWS Water Quality Facility Sizing.
- B. The design flow rate for flow based SMFs (filter strips and most manufactured treatment systems) shall be calculated as the peak discharge from design storm with the following peak rainfall intensities:
  - a. Design storm intensity for online facilities of 0.18-inches per hour (in/hr)
  - b. Design storm intensity for offline facilities of 0.10 in/hr
- C. Use a continuous simulation hydrologic/hydraulic model analysis that addresses the design equivalent of capturing and treating 80 percent of the average annual stormwater runoff.

D. Volume calculations using the 1.0-inch Design Storm and the following equation:

$$V_{\text{imp}} \text{ or } V_{\text{perv}} = 3,630 * A * \frac{(P_{\text{design}} - 0.2 * [\frac{1,000}{\text{CN}} - 10])^2}{(P_{\text{design}} + 0.8 * [\frac{1,000}{\text{CN}} - 10])}$$

where:

V = runoff volume (impervious or pervious), cubic feet

A = drainage area, acres

P = design precipitation depth, inches (assumed to be 1.0 for water quality sizing)

CN = National Resource Conservation Service (NRCS) curve number, unitless (see Appendix D)

### 2.6.2.03 Flow Control Facility Sizing

To design for flow duration matching, a hydrologic/hydraulic analytical model capable of performing a continuous simulation of peak flow rates from local long-term rainfall data must be used to determine the peak flow rates, recurrence intervals, and durations.

The Developer's Engineer may use any analytical model capable of performing a continuous simulation of peak flows from long-term local rainfall records. Regardless of how the stormwater calculations are performed, the report submitted to OLWS must show how the proposed SMFs meet the flow control performance standards. Creation of a continuous simulation hydrologic model for a specific development site requires specialized expertise and usually takes additional time and expense to develop and review. The Applicant may be required to pay additional fees to OLWS to review the Stormwater Management Plan developed using other modeling methods. These fees will be used to pay for a third-party peer review of the stormwater report, hydrologic model, and facility design.

## 2.6.3 General Design Requirements

SMFs, such as planters, swales, rain gardens, ponds, and other vegetated facilities are the required strategy to meet the stormwater management requirements for water quality treatment and flow control unless it can be demonstrated that a vegetated SMF is not possible based on infiltration limitations or site constraints. The best way to control the rate and duration of runoff is through the incorporation of infiltration using vegetated SMFs.

### 2.6.3.01 Allowable Facilities

While OLWS provides design guidance for privately maintained SMF types, not all facilities are acceptable for use in every jurisdictional area. See Section 2.6.5 for facilities that are approved for use in OLWS which cover areas managed by OLWS only.

Applicants should consult with OLWS and local agency staff to understand the types of SMFs that could be approved for use on the project.

If a proposed facility meets the DEQ criteria for a UIC, the Applicant shall comply with UIC requirements and prepare appropriate registration information for DEQ.

#### **2.6.3.02 Alternative Facilities**

Applicants may propose SMFs that are not allowed as per Section 2.6.3.01. Such a proposal will require the Applicant to submit a request for a variance per Section 2.2.8. Alternate facilities must be designed to meet the performance standards outlined in Section 2.6.

### **2.6.4 General Facility Design Requirements**

The following design requirements apply to all SMFs. Additional facility specific design criteria are included in Section 2.6.5.

#### **2.6.4.01 Location and Setbacks**

Applicants must review local zoning, building and plumbing code requirements to understand setback requirements for SMFs. The minimum setback for a stormwater facility is 5 feet from a property line, unless more distance is specified by the Developer's Engineer, geotechnical engineer, and/or by local and state minimum setback requirements. See OLWS Buffer Standards for further information on the design requirements for vegetated facilities and buffer areas.

In addition, stormwater facilities that incorporate an infiltration component are subject to all local and state minimum setback requirements. A geotechnical report is required to determine setbacks from slopes for infiltration facilities installed near slopes  $\geq 15$  percent or within 200 feet of a steep slope hazard area or landslide hazard area.

#### **Easements and Setbacks**

Piped stormwater drainage systems shall generally be located in the Public ROW. Public stormwater drainage system facilities not located in the Public ROW shall be located within an easement granted to the Public and not Oak Lodge specifically.

When design conditions require locating stormwater drains in easements, the stormwater drain shall typically be centered in the easement.

An easement shall be centered on the pipe centerline, unless otherwise approved by OLWS, and easements shall typically be exclusive. Combined easements shall be a minimum of 20 feet wide with a minimum separation of 5 feet between utilities and be approved by OLWS on a case-by-case basis and in conjunction with Clackamas County DTD.

All public manholes, junction or inlet structures in easements shall be accessible to OLWS personnel at all times. A minimum 15-foot-wide access easement is required between the nearest ROW and each structure. Paved or gravel access road may be required by OLWS, if access is deemed necessary, and otherwise unavailable.

Unless shown on a proposed plat of subdivision, all onsite easements shall be furnished to OLWS for review, approval, and recordation prior to approving the Stormwater Management Plan.

All offsite easements shall be furnished to OLWS for review, approval, and recordation prior to approving the Stormwater Management Plan.

OLWS may require that an area of 5 feet in all directions from the edge of a public manhole, catch basin, cleanout, or field inlet be encompassed in a Public ROW or easement granted to the Public.

Access easements shall be provided to all stormwater structures such as manholes, catch basins, and other related structures, as required by OLWS.

When a pipe will be stubbed, the easement shall extend a minimum of 5 feet past the end of the stub.

The center of the stormwater pipes in an easement shall be located no closer than 5 feet from the easement line.

The following easement requirements are the minimum requirements established to maintain, repair and/or replace the stormwater infrastructure or open stormwater drainage system.

- A. Easements shall be minimum 15 feet wide for pipes up to 24 inches in diameter.
- B. Easements for pipes over 24 inches in diameter shall be 20 feet wide or greater as determined by OLWS.
- C. OLWS may require wider easements for large trunk sewers, sewers greater than 10 feet deep and areas with topographic constraints such as steep slopes or sites where maintenance, repair or replacement would require a wider easement.
- D. A reduced easement width must be approved by OLWS.
- E. Easement widths shall be increased as required in 5-foot increments as per
- F. Table 5.

*Table 5. Minimum Pipe Size per Minimum Easement Width*

| <b>Pipe Size (inches)</b> | <b>Minimum Easement Width (feet)</b> |
|---------------------------|--------------------------------------|
| 6–12                      | 15                                   |
| 15 < 24                   | 15                                   |
| 24 < 54                   | 20                                   |
| > 54                      | 30                                   |

When a conservation easement is not required, the minimum open stormwater channel easement width shall extend 5 feet from each side of the top of bank of the open channel.

Structures constructed within easements shall meet the following requirements:



- A. Structures constructed within easements shall require an encroachment agreement with OLWS. Approval of the encroachment is at the discretion of OLWS and may involve the imposition of specific conditions in the granting of such. The Applicant will complete an encroachment agreement application and pay all applicable charges and fees.
- B. The encroachment agreement shall allow OLWS to remove the structure, as needed, to access the stormwater drainage system. Replacement of the structure shall be at the Owner's expense.
- C. OLWS may require increased protection for the stormwater drainage system in the vicinity of an encroachment. All special protection requirements and plans will be reviewed and approved by OLWS. All review and/or approval costs associated with this provision will be paid by the Applicant.

#### **2.6.4.02 Outlet Structures**

SMFs designed as flow through systems shall have a perforated pipe underdrain system to convey water from the facility to a flow control structure and/or downstream stormwater drainage system.

Orifice sizes for SMFs will be specified by the BMP Sizing Tool results. Orifices shall be located to prevent clogging and blockages. Outlet structures (orifices, weirs, overflow risers, etc.) shall be configured to operate as passive systems and shall not require adjustments during normal operation.

Flow control structures shall be located in an enclosed structure, outside the open water storage area, in a location that provides sufficient maintenance access for a minimum of 20 feet. Flow control manholes shall have solid locking covers, however open grates may be permitted.

Outlet structures and overflow configurations must address the 100-year overflow pathway requirements in Section 2.6.1.03.

Additional outlet requirements for specific facility types are addressed in Section 2.6.5.

#### **2.6.4.03 Stormwater Facility Signage**

All SMFs, including permeable surfaces such as pervious pavement shall have at least one informational sign and one curb stamp that is clearly visible and legible to the public.

The Permittee shall install the applicable sign(s) before OLWS deems the project is completed, and/or prior to the issuance of the Certificate of Occupancy Permit.

Signs for publicly maintained SMFs require the following:

- A. The Permittee shall be responsible for obtaining and installing the stormwater facility sign at their own expense.

- B. The material shall be aluminum with green reflective sheeting and silk screen lettering or equal as approved by OLWS.
- C. The minimum sign size shall be 12 by 18 inches. The maximum sign size shall be 24 by 30 inches.
- D. The sign shall be affixed to metal signpost, or facility fencing.
- E. The sign shall be installed near the stormwater facility in a location highly visible to the public.
- F. The sign shall be created and installed in accordance with the Clackamas County Standard Detail Drawing D.26 SWM ST-3.0 Stormwater – Surface Water Facility Signs.
- G. An electronic file format of the sign is available upon request from OLWS.
- H. Signs may be available for purchase from OLWS.

Signs for privately maintained vegetated SMFs shall be provided by the Permittee and will include:

- A. Description of the facility and its purpose
- B. Contact information for maintenance complaints or to report a problem.

Signs for privately maintained permeable surfaces, such as pervious pavement, shall be provided by the Permittee and will include at least the following information:

- A. Description of the facility and its purpose
- B. Contact information for maintenance complaints or to report a problem.
- C. Operations and maintenance instructions, such as:
  - a. Avoid tracking or piling dirt, mud, or sediment on the driveway.
  - b. If debris is tracked onto the driveway surface, clean by using a vacuum-type street cleaner during dry weather.
  - c. Maintain vegetation along the sides of the driveway to help keep erosion and sediment laden water from clogging the surface.
  - d. Do not place any sealants on the driveway.

#### **2.6.4.04 Soil Mixes for Stormwater Management Facilities**

Vegetated facilities require a soil/landscape system that simultaneously supports plant growth, soil microbes, water infiltration, nutrient and pollutant adsorption, sediment and pollutant filtration, and pollutant decomposition. Therefore, the soil mix selected for a facility is critical to its success.

Facilities that include soil, such as swales, planters, curb extensions, and basins, must use the Blended Soil Specification for Vegetated Stormwater Systems from the most currently adopted City of Portland’s Standard Construction Specifications in section

0104.14(d), titled Stormwater Facility Blended Soil. See the City of Portland's Stormwater Management Manual website for information about the most current soil specification information and a list of stormwater facility blended soil vendors and haulers.

#### **2.6.4.05 Planting and Irrigation**

SMF planting guidelines are included in Appendix B. Planting plans must meet the following requirements:

- A. Establish and implement procedures such as control of the following: invasive weeds, animal and vandal damage, mulching, re-staking, and watering to the extent needed (as determined by OLWS) to ensure plant survival. Plastic and mesh tubes are prohibited and shall not be used within a publicly maintained facility.
- B. Stormwater facilities located in the Public ROW are not permitted to include trees.
- C. Selected plant materials should be appropriate for soil, hydrologic, and other facility and site conditions (see Appendix B).
- D. For facilities located in riparian corridors, all plants within the facility area shall be appropriate native species from the plant list found in Appendix B of the Buffer Standards.
- E. No nuisance, invasive, or prohibited plants shall be used in any stormwater facilities.
- F. The design for plantings shall minimize the need for herbicides, fertilizers, pesticides, or soil amendments at any time before, during, and after construction and on a long-term basis.
- G. Plants shall be selected and planted to minimize the need for mowing, pruning, and irrigation once established.
- H. Side slopes of planted areas shall not exceed 3h:1v.

The Developer's Engineer or Landscape Architect shall determine the appropriate irrigation strategy to maintain the plant survivability. Temporary irrigation systems must be fully removed by the Developer before OLWS releases the stormwater warranty bond.

#### **2.6.4.06 Pond Embankment, Retaining Walls, Fencing, Gates, and Handrails**

Pond embankments and retaining walls are allowed to impound water to enhance the functionality of the SMF.

##### **Pond Embankments**

Pond embankments must be constructed with a maximum slope of 3h:1v on the upstream and downstream face. Side slopes within the pond must be sloped no steeper

than 3h:1v below the maximum water surface elevation, unless otherwise approved by OLWS.

### **Retaining Walls**

Retaining walls greater than 4-feet in height shall have a professional structural or geotechnical engineer registered in Oregon provide stamped design calculations and detail drawings required for the retaining wall construction, per local building code requirements. Stormwater ponds that require retaining walls will be limited to the height of 10 feet above the vegetated surface elevation for 50 percent of the circumference of the facility, and 6 feet for the remaining portion of the circumference, unless otherwise approved by OLWS.

### **Retaining Wall Ownership**

OLWS shall not have any maintenance or ownership responsibility for retaining walls. The Owner of the property (HOA) shall be responsible for the maintenance, repair, and/or replacement of the retaining wall(s) within the public easement(s) or tract(s). The ownership and maintenance responsibility for the retaining wall shall be clearly specified in the CCRs and/or within the stormwater maintenance plan.

### **Fencing, Gate and Handrails**

A minimum 6-foot high fence is required to be constructed around the parameter of all publicly maintained stormwater facilities with a designed water depth greater than 3 feet. Publicly maintained stormwater facility must provide a maintenance access gate with a minimum opening width of 12 feet wide that consists of two 6-foot sections. Fencing or handrails may be required along the top of the retaining wall in accordance with local zoning and building codes.

#### **2.6.4.07 Public Maintenance Access**

Publicly maintained stormwater facilities and structures must provide an access road designed and constructed for the intended use and purpose for accessing and maintaining the proposed SMFs. OLWS-maintained facilities should be located adjacent to the Public ROW. Public maintenance access roads shall be designed and constructed to the minimum standards as specified in Table 6.

- A. Maintenance road access for OLWS-maintained facilities shall be shown on the recorded plat and be situated in a separate tract and identified with the specific and intended use for maintenance access.
- B. OLWS may require additional protection for access roads, including fencing, signs, and/or bollards to restrict public access. Minimum maintenance access of 20 feet to structures is required.
- C. All access roads must be rated for a minimum of 80,000 pounds.

Table 6. Access Road Specifications

| SLOPE     | DESIGNATION         | WIDTH |       | SURFACE     | DESIGN NEEDS                | STRUCTURAL SUPPORT          |
|-----------|---------------------|-------|-------|-------------|-----------------------------|-----------------------------|
|           |                     | TOTAL | ROAD  |             |                             |                             |
| < 8%      | EASEMENT            | 15-ft | 12-ft | GRAVEL      | N/A                         | 8-INCH GRAVEL FILTER FABRIC |
| >8% < 12% | TRACT               | 15-ft | 12-ft | 2-INCH A.C. | W/O TURNAROUND              | 8-INCH GRAVEL FILTER FABRIC |
| 12% - 15% | TRACT               | 20-ft | 15-ft | 2-INCH A.C. | W/ TURNAROUND<br>W/ LANDING | 8-INCH GRAVEL FILTER FABRIC |
| >15%      | <b>CONTACT OLWS</b> |       |       |             |                             |                             |

### General Requirements

A Profile of the access road is required.

Maximum grade:

- A. 15 percent with a maximum 3 percent cross-slope.
- B. Special permission is required for grades over 15 percent.

Minimum width of surface:

- A. 12 feet on straight runs and 15 feet on curves.
- B. Curves will be designed with a minimum 40-foot interior radius.
- C. Access will extend to within 10 feet of all pollution control structures unless otherwise approved by OLWS.
- D. Access roads in excess of 150 feet in length is required to have a turnaround.
- E. Turnaround is required when access is taken from a collector or arterial roadway.

Provide a minimum 12-foot wide double opening gate at the entrance of the stormwater facility maintenance access.

### Access Road Contained Within a Tract of Land

All publicly maintained stormwater facilities must provide an access road in accordance with these Standards and must be contained within a Tract of Land that has an OLWS stormwater drainage easement.

### Design

Access Road:

- A. Horizontal curves
  - a. Minimum Radius for (inside) = 40 feet
- B. Vertical Curves

- a. Vertical Curves
  - i. Crest maximum  $K = 4$
  - ii. Sag maximum  $K = 6$

Where  $K = L/A$

L= algebraic difference in grades percent

A= length of vertical curve (feet)

Landing:

- A. Maximum slope = 4 percent
- B. Minimum length of 40 feet

Turnaround:

- A. Design per Clackamas County Roadway Standards – Detail C350
- B. Maximum cross slope = 4 percent
- C. Minimum width of the access road 12 feet
- D. Minimum radius for (inside) = 30 feet

Typical Surface:

Three 3-inches of class “B” asphaltic concrete and 2 inches of  $\frac{3}{4}$ ”-0” compacted crushed rock; over 8 inches of  $1\frac{1}{2}$ ”-0” compacted crushed rock; over subgrade compacted to 95 percent AASHTO T-99.

The Developer’s Engineer may submit a certified road design capable of supporting a 30-ton maintenance vehicle in all weather conditions.

Driveway Access:

All access roads shall have a standard driveway with 6 inches of concrete over 2 inches of gravel. The plan will include design of strengthened sidewalk sections (6 inches of concrete minimum) where maintenance vehicles will cross. (See D600 Clackamas County Department of Transportation).

The final plan will have to show how maintenance equipment will safely access the pond. At least one side of the detention pond is required to have access suitable for maintenance equipment (backhoe etc.). Direct access to the pond must be 15 feet wide and slopes of 4h:1v or flatter.

#### **2.6.4.08 Private Maintenance Access**

Privately maintained facilities shall be located in a manner so that the facility can be safely and efficiently maintained. Egress and ingress access routes shall be clear of any obstacles and constructed of a sufficient surface to safely convey the size and weight of vehicles, and equipment necessary to maintain, repair and replace the SMF.

#### **2.6.4.09 Underground Injection Control Registration**

Infiltrators and infiltration trenches are generally classified as UICs by DEQ. OLWS will evaluate each case and may accept ownership and/or maintenance responsibility for UICs. For UICs on private property, with the exception of single-family residential roof and footing drains, there is a requirement to register the UICs and provide site inventory data to DEQ.

Any proposed UIC facility shall be authorized pursuant to OAR 340-44-008, have an DEQ-issued UIC permit associated with the facility, or have a notice of intent to issue a UIC permit.

### **2.6.5 Stormwater Facility Design Requirements**

The following section includes SMF design guidelines for facilities approved for use in OLWS. Typical facility drawings are included in Section 5.

#### **2.6.5.01 Stormwater Planter**

Stormwater planters are walled basins that capture and treat runoff through a combination of vegetation and an engineered soil mix called biofiltration soil medium. Planters may also be used for flow control when designed with infiltration or with an underdrain with controlled outlet.

Planters treat stormwater through sedimentation of particles in ponded water; filtration and phytoremediation through contact with vegetation; and biodegradation and adsorption of pollutants through contact with soil organisms and chemical soil processes. Planters and rain gardens provide similar treatment and flow control performance, though planters require less space than rain gardens to treat the same contributing area.

#### **General Stormwater Facility Requirements**

Water quality pretreatment is generally not required.

Stormwater facilities shall be designed to treat the entire inflow.

An infiltration test shall be conducted at the location and depth of the facility.

SMFs shall have a minimum separation of 3 feet from the bottom of the facility to the seasonal high groundwater elevation or other layer that limits infiltration (e.g., bedrock, clay lens).

If infiltration is used as a design component to determine retention, then the maximum draw down time is 24 hours.

Native soil infiltration rate shall be at least 0.25 in/hr for an infiltration planter. If the infiltration rate is less than 0.25 in/hr, an underdrain is required. For native soil infiltration rates between 0.25 and 2.0 in/hr, the engineer shall determine the need for an underdrain based on design performance calculations.

Water quality planters shall be located prior to the flow control facility, and not be located downstream of detention.

Planters are designed with vertical walls and may require a structural engineer to design (because of their structural walls).

Planters receiving stormwater from downspouts need energy dissipation at the downspout outlet and planters receiving water from the street need a sediment forebay to facilitate maintenance.

Lined flow-through planters may not have setback requirements from building foundations. Check with local building code division to confirm the setback of these facilities from building, structures, and property lines.

Planters shall be designed to consider safety issues (including pedestrian safety). Curbing, fencing, railings, or placing planters above grade may be necessary. Planters located within the ROW shall be approved by the local roadway authority.

### **Dimensions**

Drain rock depth: 18 inches.

Minimum bottom width: 2.0 feet.

Minimum orifice size: filtration facilities 0.5-inches, all other 1.0 inches.

Minimum freeboard: 2.0 inches, if contributing area is less than 10,000 sf; 6.0 inches for larger contributing areas.

Maximum ponding depth: 12.0 inches.

Depth of biofiltration mix: 18 inches minimum.

### **Materials**

When required, waterproof liners shall be 30 mil polyvinyl chloride (PVC) membrane or equivalent.

Planter walls and bottom (when needed) shall be made of concrete. Chemically treated wood that can leach out toxic chemicals and contaminate stormwater shall not be used.

Drain rock is required below the biofiltration soil mix. For infiltration planters, use 0.75 to 1.5 inches of washed drain rock. Drain rock shall conform to Oregon Department of Transportation (ODOT) Standard Specifications 00430.11 or AASHTO No. 4.

When used, underdrains shall be a minimum of 4-inches diameter for private facilities and a minimum of 6 inches for publicly maintained facilities. Underdrains shall be slotted or perforated PVC that conforms to American Society for Testing and Materials (ASTM) D 3034, with a pipe stiffness of 46 pounds per square inch (psi) or a minimum standard dimensional ratio (SDR) of 35 or approved equal. Installation and testing requirements shall conform to the current OPSC and ODOT Standard Specification 02415.50 for PVC pipe. Slotted perforations (0.064-inch-wide x 1.00 inch-long, spaced 0.3-inch on center) are preferred and less susceptible to clogging.



Drain rock and biofiltration soil mix shall be separated by a 2-inch to 3-inch choker course layer. Choker course shall conform to ODOT Standard Specifications 00430.11.

Biofiltration soil mix must support long-term plant and soil health and provide treatment for water as it moves through the soil column. See Section 2.6.4.04 for soil mix requirements.

Plant selection shall follow the Planting Guide in Appendix B. Plant selection shall be based on water level tolerances during the rainy season, as well as the ability of plants to withstand dry summer conditions. Species should be selected that are suitable for the hydrologic, light, and soil conditions in the proposed planter. Planters shall be designed so that they do not require mowing.

### **2.6.5.02 Rain Garden**

Rain gardens are vegetated depressions that capture and treat runoff with a combination of vegetation and biofiltration soil medium. Rain gardens may also be used for flow control when designed to infiltrate or with an underdrain with controlled outlet.

Rain gardens treat stormwater through sedimentation of particles in ponded water, filtration, and phytoremediation through contact with vegetation, and biodegradation and adsorption of pollutants through contact with soil organisms and chemical soil processes. Rain gardens are ideal for residential and small commercial sites, within parking lots, and along roadways. They can help fulfill landscaping requirements.

Rain gardens may take a variety of shapes to fit the site layout. Rain gardens may be round, linear, or irregular shape and can have multiple distinct depressions, called cells, which can be linked hydraulically via overflow structures or berms.

#### **Site Requirements**

Pretreatment is not required.

An infiltration test shall be conducted at the location and depth of the facility.

Rain gardens shall have a minimum separation of 3 feet from the bottom of the facility to the seasonal high groundwater elevation or other layer that limits infiltration (e.g., bedrock, clay lens).

If infiltration is used as a design component to determine retention, then the maximum draw down time is 24 hours.

The native soil infiltration rate shall be at least 0.25 in/hr for an infiltration rain garden. If the infiltration rate is less than 0.25 in/hr, an underdrain is required. For native soil infiltration rates between 0.25 and 2.0 in/hr, the engineer shall determine the need for an underdrain based on design performance calculations.

Water quality rain gardens shall not be located downstream of detention.

#### **Dimensions**

Minimum drain rock depth: 18 inches.

Minimum bottom width: 2.0 feet

Planted side slopes: no steeper than three horizontal to one vertical (3h:1v). Rock or concrete walls may be used for areas that require steeper side slopes.

Minimum orifice size: filtration facilities 0.5-inches, all other 1.0 inch.

Minimum freeboard: 2.0 inches, if contributing area is less than 10,000 sf; 6.0 inches for larger contributing areas.

Maximum ponding depth: 12.0 inches.

Depth of biofiltration mix: 18 -inches minimum.

### **Materials**

When required, waterproof liners shall be 30 mil PVC membrane or equivalent.

Drain rock is required below the biofiltration soil mix. For infiltration rain gardens, use 0.75 to 1.5 inches of washed drain rock. Drain rock shall conform to ODOT Standard Specifications 00430.11 or AASHTO No. 4.

When used, underdrains shall be a minimum of 4-inches diameter for private facilities and a minimum of 6 inches for public facilities. Underdrains shall be slotted or perforated PVC that conforms to ASTM D 3034, with a pipe stiffness of 46 psi or a minimum SDR of 35 or approved equal. Installation and testing requirements shall conform to the current UPC and ODOT Standard Specification 02415.50 for PVC pipe. Slotted perforations (0.064-inch-wide x 1.00 inch-long, spaced 0.3-inch on center) are preferred and less susceptible to clogging.

Drain rock and biofiltration soil mix shall be separated by a 2- to 3-inch choker course layer. Choker course shall conform to ODOT Standard Specifications 00430.11.

Biofiltration soil mix must support long-term plant and soil health and provide treatment for water as it moves through the soil column. See Section 2.6404 for soil mix requirements.

Plant selection shall follow the Planting Guide in Appendix B. Plant selection shall be based on water level tolerances during the rainy season, as well as ability of plants to withstand dry summer conditions. Species should be selected that are suitable for the hydrologic, light, and soil conditions in the proposed rain garden. Rain gardens shall be designed so that they do not require mowing.

### **2.6.5.03 Vegetated Swale**

Vegetated swales are gently sloping, landscaped depressions that collect, convey, and treat stormwater runoff with a combination of vegetation and a biofiltration soil medium. Swales may also be used for flow control when designed with infiltration or with an underdrain with controlled outlet. Vegetated swales are designed much like rain gardens, but with a sloping bottom.

Vegetated swales reduce stormwater flow rates, volume, and temperature and improve water quality. Pollutants are removed as runoff passes through the vegetation and soil

media and is collected in an underlying layer of gravel or drain rock. Swales are ideal for residential and small commercial sites, within parking lots, and along roadways. They can help fulfill landscaping requirements.

### **Site Requirements**

Pretreatment is not required.

An infiltration test shall be conducted at the location and depth of the facility.

SMFs shall have a minimum separation of 3 feet from the bottom of the facility to the seasonal high groundwater elevation or other layer that limits infiltration (e.g., bedrock, clay lens).

If infiltration is used as a design component to determine retention, then the maximum draw down time is 24 hours.

The native soil infiltration rate shall be at least 0.25 in/hr for an infiltration swale. If the infiltration rate is less than 0.25 in/hr, an underdrain is required. For native soil infiltration rates between 0.25 and 2.0 in/hr, the Developer's Engineer shall determine the need for an underdrain based on design performance calculations.

Water quality swales shall not be located downstream of detention.

### **Dimensions**

Longitudinal Slope: range is from 0.5 to 6 percent (for steeper sites, use check dams or similar features to slow flow velocity and create step pools to promote infiltration.) See Drawing 206 in Section 5.

Minimum drain rock depth: 18 inches.

Minimum bottom width: 2.0 feet.

Planted side slopes: no steeper than three horizontal to one vertical (3h:1v). Rock or concrete walls may be used for areas that require steeper side slopes.

Minimum orifice size: 0.5-inches.

Minimum freeboard: 2.0 inches, if contributing area is less than 3,000 sf; 6.0 inches for larger contributing areas.

Maximum ponding depth: 12.0 inches.

Depth of biofiltration mix: 18 inches minimum.

### **Materials**

When required, waterproof liners shall be 30 mil PVC membrane or equivalent.

Drain rock is required below the biofiltration soil mix. For infiltration swales, use 0.75 to 1.5 inches of washed drain rock. Drain rock shall conform to ODOT Standard Specifications 00430.11 or AASHTO No. 4.

When used, underdrains shall be a minimum of 4-inches diameter for private facilities and a minimum of 6 inches for public facilities. Underdrains shall be slotted or perforated PVC that conforms to ASTM D 3034, with a pipe stiffness of 46 psi or a

minimum SDR of 35 or approved equal. Installation and testing requirements shall conform to the current UPC and ODOT Standard Specification 02415.50 for PVC pipe. Slotted perforations (0.064-inch-wide x 1.00 inch-long, spaced 0.3-inch on center) are preferred and less susceptible to clogging.

Drain rock and biofiltration soil mix shall be separated by a 2-inch to 3-inch choker course layer. Choker course shall conform to ODOT Standard Specifications 00430.11.

Biofiltration soil mix must support long-term plant and soil health and provide treatment for water as it moves through the soil column. See Section 2.6.4.04 for soil mix requirements.

Plant selection shall follow the Planting Guide in Appendix B. Plant selection shall be based on water level tolerances during the rainy season, as well as ability of plants to withstand dry summer conditions. Species should be selected that are suitable for the hydrologic, light, and soil conditions in the proposed swale. Swales shall be designed so that they do not require mowing.

#### **2.6.5.04 Filter Strip**

Filter strips are gently sloped areas intended to remove pollutants using sheet flow that runs off adjacent impervious surfaces. Filter strips are vegetated with grasses and densely spaced groundcovers that filter pollutants and reduce the velocity of stormwater.

Filter strips are a good choice for use adjacent to uncurbed roads where a gravel shoulder or shallow gravel strip helps to uniformly distribute flow. They can also be good choices for small projects; for example, to provide water quality treatment for roof or driveway runoff before it is discharged into a drywell, infiltration trench, or other facility.

#### **Site Requirements**

Pretreatment not required.

Filter strips are appropriate for all soil types.

Flow shall be distributed evenly along the length of the strip. This may require additional structures or design features to fully spread point discharges along the length of the strip.

Filter strips shall be a minimum of 50 feet from wetlands, rivers, streams, and creeks.

The maximum flow path distance of the contributing impervious surface shall be 100 feet to prevent concentrated flow.

#### **Dimensions**

Slope (measured in the direction of flow): 0.5 to 10 percent

Minimum width: 5 feet, measured in the direction of flow

Maximum slope of contributing impervious area (measured in the direction of flow): 6 percent. Steeper slopes may be allowed with an appropriate energy dissipation structure between the impervious area and filter strip.

Maximum design flow depth: 1.0 inch for water quality flow.

Maximum design velocity: 0.5-feet per second for water quality flow.

The filter strip width and slope shall be determined through iterative calculations, using the following two equations:

and

where:

Q = water quality flow rate, cubic feet per second

T = filter strip width (measured in the direction of flow), feet

S = filter strip slope (measured in the direction of flow), feet per foot

y = flow depth, feet (maximum 0.083)

n = Manning's roughness coefficient, unitless

V = flow velocity, feet per second (maximum 0.5)

### **Materials**

Plant selection shall follow the Planting Guide in Appendix B. Establish dense plant growth of groundcovers, herbaceous plants, and shrubs, with a goal of 95 percent coverage. Filter strips often experience moist soil conditions during the wet, rainy season and dry soil conditions during warm summers. Plant selection should respond to specific site conditions for each facility.

#### **2.6.5.05 Drywell**

A drywell is an underground perforated pipe or chamber that collects stormwater runoff and gradually discharges it into underlying soils.

Drywells are "Class V Injection Wells" under the federal Underground Injection Control Program (OAR Division 44). UICs are either classified as exempt (no registration required), authorized by rule, or authorized by permit. Designers are urged to review current regulations and UIC registration materials from DEQ.

Drywells do not provide water quality treatment, so water quality treatment is required before stormwater discharges into drywells. Drywells utilized exclusively to infiltrate the roof runoff from one single-family residential roof are exempt, and a silt trap is the only pretreatment necessary. An approved water quality pretreatment device is required for multiple single-family residential roofs to discharge into a common drywell. Where space is available, rain gardens are preferred to manage residential runoff because they provide both treatment and flow control (and are not regulated UICs). The intent of this section is to support compliance with the water quality treatment requirements as specified by the State of Oregon UIC regulations.

### **Site Requirements**

Native soil design infiltration rate shall be at least 2.0 in/hr. Apply a factor of 2 to the tested infiltration rate to determine the design rate.

Bottom of drywells and other types of stormwater injection devices shall be at least 3 feet above seasonal high groundwater or impermeable layer.

The edge of excavation for the drywell shall be at least 10 feet from building foundations, unless otherwise specified by the local building code division.

Drywells are not allowed on slopes of 15 percent or more.

Drywells are not allowed in areas with existing soil or groundwater contamination

Drywells may be allowed to be located under the travel surface within the Public ROW. The minimum setback from the edge of the travel lane is 5 feet. Check with the local roadway authority,

Soil surrounding the drain rock, surrounding the drywells shall be native, uncompacted soil.

Drywells are not allowed within 500 feet of drinking water or irrigation wells or within the 2-year time of travel setback to drinking water or irrigation wells.

Infiltration rates shall be tested after construction and testing shall be overseen by the Developer's Engineer to confirm that the dry well provides adequate infiltration capacity for the relevant design storm.

A water quality pretreatment device is required, unless the drywell is receiving runoff from only one single-family residential roof,

The following facilities are approved for pretreatment:

- A. Facilities identified for water quality treatment in Section 2.6.3.01.
- B. Catch basins with a 36-inch sump and trapped outlet (snout).

If the facility is designed to infiltrate the 100-year storm event, then an emergency overflow pathway is not required.

### **Dimensions**

Private: Diameter: 2-feet minimum

Publicly Maintained: 4-feet minimum

The required storage capacity within the drywell structure and surrounding drain rock is determined by subtracting the volume of water that can infiltrate out of the facility within a 24-hour period from the runoff volume generated by the contributing drainage area during a 25-year, 24-hour storm event.

### **Materials**

Place 12-inch minimum layer of 1.50-inch to 0.75-inch round rock that conforms to ODOT Standard Specifications 00430.11 or AASHTO No. 4 between drywell structure

and earth wall. The drain rock should extend from 1 foot below the drywell structure up to the lid.

#### **2.6.5.06 Infiltration Trench or Gallery**

An infiltration trench is a linear, gravel-filled trench that distributes stormwater to underlying soils. An infiltration gallery includes underground chambers to increase subsurface storage.

Infiltration trenches that receive only surface runoff (no underdrains or subsurface pipe) are not classified as UICs. Infiltration trenches with underdrains and infiltration galleries are “Class V Injection Wells” under the federal UIC program (OAR Division 44). UICs are classified either as: exempt (no registration required), authorized by rule, or authorized by permit. Infiltration trenches and galleries do not provide water quality treatment, so water quality treatment is required before stormwater discharges into the facility.

Water quality treatment is required before stormwater discharges into infiltration galleries, though galleries used exclusively for single-family residential roof runoff are exempt and a silt trap is the only pretreatment necessary. Where space is available, rain gardens are preferred to manage residential runoff because they provide both treatment and flow control (and are not considered UICs).

An infiltration test shall be conducted at the location and depth of the facility. Designers are encouraged to review current regulations and UIC registration materials from DEQ.

#### **Site Requirements**

Trenches or galleries are not approved for slopes greater than 15 percent, unless approved by a geotechnical engineer.

Trenches or galleries within 200 feet of a steep slope or a mapped landslide hazard area require the review and approval of a geotechnical engineer.

Infiltration trenches or galleries are not allowed in the Public ROW.

Trenches shall not be located where they will be subject to vehicular traffic.

Soil surrounding trenches or galleries shall be native, uncompacted soil.

Bottom of trench or gallery shall be at least 3 feet above seasonal high groundwater elevation.

Native soil design infiltration testing rate shall be at least 1.00 in/hr which includes the applicable safety factor of two, therefore the minimum infiltration design rate is 0.50 in/hr.

Trenches or galleries are not allowed within 500 feet of drinking water or irrigation wells or within the 2-year time of travel setback to drinking water or irrigation wells.

Infiltration trenches or galleries shall be located outside of tree protection zones or at least 10 feet from the base of newly planted trees and large shrubs.

Water quality treatment is required unless the infiltration trench or gallery is receiving only single-family residential roof runoff, then an approved pretreatment device will suffice. The following facilities are approved for pretreatment:

- A. Facilities identified for water quality treatment in Section 2.6301.
- B. Private catch basins with a 36-inch sump and trapped outlet (snout).

#### **Dimensions**

The required storage capacity within the structural chambers and surrounding drain rock is determined by subtracting the volume of water that can infiltrate out of the facility within a 24-hour period from the runoff volume generated by the contributing drainage area during a 25-year, 24-hour storm event.

The maximum draw down time is 24 hours.

Minimum infiltration trench dimensions shall be 12 inches deep and 2 feet wide, filled with drain rock.

An observation well is required for all infiltration galleries and for infiltration trenches that exceed 50 feet in length.

#### **Materials**

Drain rock shall be 0.75-inch to 1.50-inch of granular drain backfill material. Drain rock shall conform to ODOT Standard Specifications 00430.11 or AASHTO No. 4.

If applicable, the distribution pipe in an infiltration trench shall be perforated, 6-inch-diameter PVC pipe that conforms to ODOT Standard Specification 02410.70. The IE shall be at least 12 inches below finished grade.

#### **2.6.5.07 Constructed Wetland**

Constructed wetlands are SMFs that are designed to emulate natural wetlands, with shallow water that varies in depth, and varied side slopes. They are saturated or have standing water for part of the year, rather than draining over a short period of time as rain gardens are designed to do. Wetlands are inundated or saturated at a frequency and duration sufficient to support a prevalence of hydrophytic vegetation.

Constructed wetlands present an opportunity to integrate wildlife habitat and a public amenity into the landscape of a large residential, institutional, or commercial development. Constructed wetlands with healthy, thriving plants provide excellent water quality treatment. They require a large surface area and a large contributing area to ensure that wetland conditions are maintained.

#### **Site Requirements**

Site shall have adequate space for maintenance access that allows equipment access within 20 feet of the flow control, water quality devices and other structures as specified by OLWS.

Constructed wetlands are best for Type C and D soils or in areas with a high groundwater table. Soils shall be saturated for a long enough time to maintain wetland



vegetation. The soil profile should be investigated to determine whether appropriate site soils exist and if any soil amendments need to be added to assist with initial plant establishment.

Waterproof liners may be used to maintain saturated conditions.

Constructed wetlands may be irregularly shaped, with a sinuous flow path and a variety of side slopes and benches incorporated to maximize plant establishment and diversity.

Vector (mosquito) control is an important design consideration for any facility that has standing water for extended periods of time. Bat boxes, diverse planting, and other design strategies to encourage biological controls can help to keep mosquito populations in balance.

### **Dimensions**

Constructed wetlands can be sized for water quality treatment or a combination of treatment and flow control, similar to ponds. However, constructed wetlands will have a larger surface area, varied side slopes, and shallower ponding areas to maximize water quality treatment.

Two cells are required, with the first cell, the sediment forebay, containing 10 percent of the design volume, unless pretreatment is provided in a different facility. A sediment forebay provides a clear visual indicator of when maintenance is needed.

Water depth in a constructed wetland may vary in the different cells. Determine the average, maximum, and minimum depths for permanent pool in each cell of the wetland.

Design varied side slopes, water depths, and planting zones to provide a variety of habitat and maximize treatment.

Bottom width: minimum 3.0 feet

Maximum ponding depth: 4.0 feet

Average ponding depth:  $\leq 2.5$  feet

Side slopes: no greater than 5h:1v below maximum ponding depth

Side slopes: no greater than 3h:1v above maximum ponding depth

### **Materials**

When required, waterproof liners shall be 30 mil PVC membrane or equivalent.

Investigate the soil profile and determine whether appropriate site soils exist and if any soil amendments need to be added.

Plant selection shall follow the Planting Guide in Appendix B. Plant selection shall be based on water level tolerances during the rainy season, as well as the ability of plants to withstand dry summer conditions. Species should be selected that are suitable for the hydrologic, light, and soil conditions in each of the proposed wetland cells.

Woody vegetation shall be used to provide shade over standing water and to provide structural diversity within the constructed wetland. Shrubs and trees shall be sited to promote long-term health and survival, minimize maintenance, and protect lines of sight. Shrubs and trees shall be located to allow for maintenance access to the treatment area.

Woody vegetation shall not be planted within 20 feet of inlet and outlet structures.

### **Overflow Spillway**

All constructed wetlands shall have an emergency overflow spillway or other overland flow location that will safely pass runoff from the 100-year storm event over the embankment in the event of control structure failure or for storm events that exceed the design of the control structure.

Locate the spillway to direct overflows safely toward the 100-year emergency overflow pathway.

Protect the spillway with riprap or an approved material that extends to and is an appropriate distance beyond the bottom of the berm embankment. Fill the voids of the riprap with soil and vegetate the spillway with grass or ground cover. The selection of the vegetation on the spillway shall consider the required design capacity.

The IE of the spillway shall be a minimum of 6 inches above the 10-year water surface elevation.

Provide a minimum of 12 inches of freeboard through the spillway between the 100-year water surface elevation and the top of the berm.

Alternate methods to accomplish the design intent of the emergency spillway will be acceptable, as long as they accomplish the same level of protection.

### **2.6.5.08 Pond**

Stormwater ponds can provide water quality treatment, infiltration, and flow control to mitigate post-construction stormwater runoff. Ponds are a good choice where there is a large contributing area draining to a single facility, where there is adequate space to design a pond that can be integrated into the landscaping, and where it is accessible for maintenance. Stormwater ponds can be used to meet both water quality treatment and flow control performance standards. When site conditions allow, ponds should be designed as infiltration facilities or with an infiltration component in addition to a detention component to meet the flow control performance standard. An infiltration test shall be conducted at the location and depth of the facility.

The stormwater report and engineered drainage plans, in addition to documentation of existing and proposed conditions, shall include, at a minimum, the flow control structure rim elevation, the pond grading plan, the outlet pipe IE, the elevation of the top of the berm, the elevation of the top of the overflow structure, all pipe diameters, and any deviation in shear gate/lift assembly from OLWS's Standard Drawings.

### **Site Requirements**

Pond type selection shall be appropriate for soil characteristics (e.g., if soils have adequate infiltration capacity, design an infiltration pond rather than a facility with a controlled downstream outlet)

The minimum setback of a pond from the edge of the top of bank, wall, or toe of an embankment to the nearest property line must be horizontal for a minimum of 5 feet, or greater if recommended by a civil or geotechnical engineer.

A geotechnical report is required to determine setbacks of ponds near slopes  $\geq 15$  percent or within 200 feet of a steep slope hazard area or landslide hazard area.

Vector (mosquito) control is an important design consideration for any facility that has standing water for extended periods of time. Bat boxes, diverse planting, and other design strategies to encourage biological controls can help to keep mosquito populations in balance.

### **Dimensions**

May include two cells, with the first cell (forebay) containing approximately 10 percent of the design surface area. Forebays simplify maintenance and are strongly encouraged. Maintenance access shall be provided to the forebay.

Maximum side slopes: 3h:1v

Length to width ratio:  $\geq 3:1$

### **Materials**

When required, waterproof liners shall be 30 mil PVC membrane or equivalent.

Soil amendments shall meet the requirements of Section 2.6.4.04.

Plant selection shall follow the Planting Guide in Appendix B. Plant selection shall be based on water level tolerances during the rainy season, as well as the ability of plants to withstand dry summer conditions. Species should be selected that are suitable for the hydrologic, light, and soil conditions in the pond.

Woody vegetation shall be used to provide shade over standing water and to provide structural diversity within the pond. Shrubs and trees shall be sited to promote long-term health and survival, minimize maintenance, and protect lines of sight. Shrubs and trees shall be located to allow for maintenance access to the treatment area.

Woody vegetation shall not be planted within 20 feet of inlet and outlet structures.

### **Outlet Structures**

Flow Control Structure: Flow control structures for ponds shall be located in an enclosed manhole, outside the open water storage area, in a location that allows equipment maintenance access and access during high flow events. Access to a flow control structure, not located in a public roadway, shall be provided within 12 feet of the edge of a vehicular access, measured from center of flow control structure, when designed to be accessed perpendicularly by the maintenance vehicle and within 6 feet when designed to be accessed from the front of the maintenance vehicle. The flow control

structure may be farther from the edge of the roadway if a public access road is provided that allows for maintenance trucks to get within the appropriate distances.

**Secondary Outlet.** Detention ponds shall have a secondary pond outlet structure, such as a catch basin with grated lid located along an interior side slope. This secondary pond outlet will serve as a backup to convey stormwater to the flow control manhole should the primary pond outlet become clogged. The lip elevation of the secondary pond outlet should be set at approximately the 10-year design water surface. See Appendix C for a graphical depiction showing a secondary pond outlet.

Flow control manholes connected to the public stormwater system requires Clackamas County approval and shall comply with all applicable WES Standard Drawings.

Orifices less than 2.0 inches shall be made of material (e.g., stainless steel, high-density polyethylene pipe [HDPE], or PVC) shall be used to make the orifice plate. The plate shall be attached to the concrete or structure.

### **Overflow Spillway**

In addition to primary and secondary outlets, ponds shall have an emergency overflow spillway that will safely pass runoff from a post-developed 100-year Design Storm to the downstream emergency overflow pathway. The design intent is to protect the integrity of the pond, as well as associated embankments and downstream properties, during large storm events and/or failure of the flow control structure. Secondary spillway shall meet the following criteria:

Locate the spillway to direct overflows safely toward the 100-year overflow pathway.

Locate the spillway in existing soil wherever possible. Protect the spillway with riprap or an approved material that extends to, and is an appropriate distance beyond, the bottom of a berm embankment.

The IE of the spillway shall be a minimum of 6 inches above the 25-year water surface elevation.

Provide a minimum of 12 inches of freeboard through the spillway between the 100-year water surface elevation and the top of the berm.

Alternate methods to accomplish the design intent of the emergency spillway will be acceptable, as long as they accomplish the same level of protection.

### **Pond Interior Maintenance Access**

Design ponds with access suitable for maintenance equipment (backhoe, etc.) to safely access the bottom of the interior of the pond. The purpose of this requirement is to provide access suitable for sediment removal by OLWS equipment.

The interior pond access will begin at the edge of the required pavement and end at the lowest elevation of the pond. The minimum access requirement is at least 15 feet wide with slopes no steeper than 4:1.

The pond interior access shall be constructed of 8 inches of gravel, pervious pavers, or native vegetation (no trees or shrubs). The access can be constructed of compacted

native material suitable for the intended seasonal use. Other materials will be reviewed and approved on a case-by-case basis.

#### **2.6.5.09 Structural Detention**

Structural detention facilities include underground tanks and vaults that temporarily store water must be designed in accordance with the custom pond sizing feature that is part of the BMP Sizing Tool program. Structural detention facilities are appropriate for commercial sites, industrial locations, and multi-family sites. They can be designed to reduce the runoff rate and duration of flow to meet the flow control performance standards. Structural detention facilities alone do not provide water quality treatment, so a separate water quality treatment facility is necessary to meet the water quality performance standards.

Detention pipes and vaults are not allowed for use on developments that convey public waters, such as stormwater runoff from public roadways. Structural detention design shall demonstrate that the facilities have adequate maintenance access of 20 feet to the flow control and water quality structures, can withstand vehicular and other structural loadings, will be stable, have been designed to counteract buoyancy forces in areas of high groundwater, and that the materials can withstand chemical properties of soils on the site.

The stormwater report and design drawings, in addition to documentation of existing and proposed conditions, shall include, at a minimum, the flow control structure rim elevation, the storage pipe IE, the outlet pipe IE, the elevation of the top of the storage pipe, the elevation of the top of the overflow pipe, all pipe diameters, and any deviation in shear gate/lift assembly from OLWS's Standard Drawings.

#### **Site Requirements**

Structural detention facilities shall be located to avoid conflicts with other underground utilities.

Regular maintenance is essential to ensure continued function of underground detention facilities. Maintenance access shall be provided to allow sediment removal from the length of the facility and to maintain the outlet control structure. Facility location shall be chosen to maximize access for maintenance and replacement.

Pipes and vaults shall be placed on stable, consolidated native soil with suitable bedding. Pipes and vaults are not allowed in fill slopes unless a geotechnical analysis is performed for stability and construction practices.

#### **Dimensions**

Detention Pipe:

- A. Minimum diameter: 36.0 inches
- B. Pipe bottom shall be flat or gently sloped:  $\leq 0.5$  percent
- C. Maximum distance between pipe bottom and finish grade: 20.0 feet
- D. Sediment storage depth in upstream standard manhole: 6.0 inches minimum

- E. Minimum freeboard: 6.0 inches, measured from the maximum design water surface elevation and the overflow elevation in the control structure.

Detention Vault:

- A. Vault bottom shall be flat or gently sloped to the center, forming a “V”:  $\leq 0.5$  percent
- B. Minimum sediment storage depth: 6.0 inches
- C. Minimum freeboard: 6.0 inches, measured from the maximum design water surface elevation and the overflow elevation in the control structure.

Private facilities may use a 1.0-inch-diameter orifice if the structural detention facility is preceded by an approved water quality filtration device.

**Materials**

Private Maintained Detention Pipe: Stormwater detention/conveyance pipes that are located solely on private property shall be constructed of a material in accordance with OPSC. A plumbing permit to construct the pipe shall be obtained by the local plumbing authority, and the Developer’s Engineer shall certify the infrastructure was constructed in accordance with the approved plans. Galvanized metals leach zinc into the environment, especially in standing water situations. This can result in zinc concentrations that can be toxic to aquatic life. Therefore, galvanized materials shall not be used in stormwater facilities and stormwater drainage systems.

Publicly Maintained Detention Pipe: For publicly maintained facilities, the detention pipe material shall be concrete. The joints shall conform to technical and manufacturer's specifications.

Detention vaults shall be constructed of structural reinforced concrete (3,000 psi, ASTM 405). All construction joints shall be provided with water stops.

A flow control manhole shall be provided to regulate outflow from the structural detention facility. Flow control manholes connected to the public stormwater system requires Clackamas County approval and shall comply with all applicable WES Standard Drawings.

Orifice structure material shall be HDPE or PVC. A thin material (e.g., stainless steel, HDPE, or PVC) shall be used to make the orifice plate. The plate shall be attached to the structure.

**Access**

Detention pipes more than 50 feet long shall provide an access riser at each end for maintenance. Detention pipes over 200 feet long shall have an access riser at the upstream end and access risers at least every 100 feet.

Access for detention vaults may be provided by use of removable panels, hatches, or ring and cover.

36-inch minimum diameter corrugated metal riser-type manholes of the same gauge as the detention pipe material may be used for access along the length of the detention

pipe and at the upstream terminus of the detention pipe. The top slab is separated (1-inch minimum gap) from the top of the riser to allow for deflections from vehicle loadings without damaging the riser pipe.

All detention pipe, vault access and control structure openings shall be readily accessible by maintenance vehicles.

Detention pipes and vaults shall comply with the OSHA and Oregon OSHA confined space requirements, which include, but are not limited to, the preparation of ventilation plans and clearly marked entrances to confined space areas.

Internal structural walls of large vaults shall be provided with openings sufficient for maintenance access between cells. The openings shall be sized and situated to allow access to the maintenance “V” in the vault floor.

For detention vaults, the recommended minimum internal height is 7 feet from the highest point of the vault floor (not sump), and the recommended minimum width is 4 feet. However, concrete vaults may be a minimum 3 feet in height and width if there are access manholes at each end, and if the width is no greater than the height. Minimum internal height requirements do not apply for any areas covered by removable panels.

#### **2.6.5.10 Proprietary Stormwater Treatment Device**

Proprietary Stormwater Treatment Devices are manufactured technologies used to address the stormwater quality impacts of land development, including removing pollutants through physical, chemical, or biological treatment processes. These SMFs rely upon a variety of mechanisms to remove pollutants.

Proprietary Stormwater Treatment Devices include hydrodynamic separators, cartridge filters, and other emerging treatment technologies that are designed to remove pollutants from stormwater. Proprietary devices are generally grouped by their use for pretreatment, oil removal, enhanced treatment, basic treatment, phosphorus removal and construction pollutant management. There are numerous manufacturers that build Proprietary Stormwater Treatment Devices.

Stormwater treatment technologies are reviewed and certified by several agencies. OLWS follows the Technology Assessment Protocol – Ecology (better known as the TAPE Program), administered by the Washington State Department of Ecology (Ecology). OLWS allows the use of Proprietary Stormwater Treatment Devices that have a General Use Level Designation (GULD) for basic, dissolved metals, or phosphorus treatment. Devices with Pilot Use Level Designation or Conditional Use Level Designation are not allowed. OLWS may require pretreatment facilities to improve the performance of Proprietary Stormwater Treatment Devices.

The Proprietary Stormwater Treatment Devices that have been tested and approved under Ecology’s TAPE program are regularly updated on the TAPE Program website.

Proprietary Stormwater Treatment Devices approved by Ecology with GULD and classified as Basic Treatment may be utilized to satisfy the stormwater water quality

treatment requirements when sized to capture and treat the first 1 inch of stormwater runoff within a 24- hour period; and are sized as specified in the Ecology-approved GULD.

The use of Proprietary Stormwater Treatment Devices approved by Ecology is allowed for use on privately maintained facilities.

The use of Proprietary Stormwater Treatment Devices that will be maintained by a public agency shall be approved by OLWS. Any device requiring the replacement of specific manufacture filter cartridges and/or media will not be allowed without the specific approval of OLWS for SMFs which will be publicly maintained and/or accepts stormwater runoff from public improvements.

### **Site Requirements**

Proprietary Stormwater Treatment Devices for water quality treatment shall not be located downstream of flow control facilities.

Proprietary Stormwater Treatment Devices may be located on a range of site conditions. Site requirements vary by type of system. Review the manufacturer’s restrictions and recommendations when selecting an appropriate treatment device and configuration for the development and site conditions.

Proprietary Stormwater Treatment Devices shall be a minimum of 5 feet from structures.

Proprietary Stormwater Treatment Devices that are publicly maintained, and require staff to enter, shall provide a minimum of 78 inches of head room.

The device shall be designed to safely convey the storm event as specified in this section, and if applicable provide an emergency overflow pathway.

Devices shall be readily accessible by maintenance vehicles at a minimum distance of 20 feet and in accordance with manufacturer recommendations.

### **Dimensions**

Proprietary Stormwater Treatment Devices may be configured as inline systems or offline systems with high flow bypasses, in accordance with manufacturer specifications.

Proprietary stormwater treatment devices shall be designed to treat the peak flow or total volume from the water quality storm event, as defined in Section 2.6.1

Calculations to determine the required size, number, or configuration of the Proprietary Stormwater Treatment Device must be based on the design guidelines specified in the GULD approval documents from Ecology. When sizing Proprietary Stormwater Treatment Devices for water quality treatment, Applicants shall use the treatment flow rates identified in the TAPE approval documents.

#### **2.6.5.11 Sheet Flow Dispersion**

Sheet flow dispersion is one of the simplest methods of stormwater management. Sheet flow dispersion is the dispersion of concentrated flows from driveways, roadways, or



other impervious surfaces through a vegetated pervious area. Because flows are already dispersed as they leave the surface (i.e., not concentrated), they need only traverse a narrow band of adjacent vegetation for effective flow attenuation and treatment.

Sheet flow dispersion is applicable for impervious surfaces with slopes less than 15 percent, such as driveways, sport courts, patios, roofs without gutters, recreational vehicle pads, or other situations where concentration of flows can be avoided.

Sheet flow dispersion is a preferred stormwater management strategy for impervious surfaces in rural areas, driveways, and agricultural buildings. The discharge shall not be directly connected to a drainageway, Stormwater Drainage System, or other Public Stormwater System.

### **Site Requirements**

Dispersion is not permitted within potential landslide areas. OLWS may require a geotechnical report to verify the site soils are suitable for sheet flow dispersion.

Dispersion is not permitted within 10 feet of the top of a slope greater than 25 percent.

Dispersion is not permitted over contaminated sites or abandoned landfills.

For sites with septic systems, the discharge point shall be downgradient of the drain field primary and reserve areas. This requirement may be waived if site topography clearly prohibits flows from intersecting the drain field.

Area receiving flow shall be protected from compaction during construction, or substantial soil amendment may be required prior to final site stabilization.

No erosion or flooding of downstream properties may result.

### **Dimensions**

A 2-foot-wide transition zone to discourage channeling shall be provided between the edge of the contributing impervious area and the downslope vegetation. This may be an extension of subgrade material (crushed rock), modular pavement, drain rock, or other material approved by OLWS. The transition zone may be narrowed for sidewalks and pathways, if approved by OLWS.

A 10-foot-wide vegetated buffer shall be provided for up to 20 feet of width of contributing impervious surface. An additional 5 feet of buffer width shall be added for each additional 20 feet of width of contributing area or fraction thereof.

The flow path shall be covered with well-established lawn or landscape area (landscaping with well-established groundcover, or native vegetation with natural groundcover). The groundcover shall be dense enough to help disperse and infiltrate flows and to prevent erosion.

#### **2.6.5.12 Pervious Pavement**

Pervious pavement is a walking or driving surface designed to allow rainfall to percolate into the underlying soil or aggregate storage reservoir beneath the pavement. The wearing course (surface layer) of pervious pavement may be any of the following:

Porous asphalt is open-graded asphalt that allows water to percolate or infiltrate into underlying soils.

Pervious concrete omits fines in the aggregate to create stable air pockets that allow water to drain to the base below. There is an inverse relationship between porosity and strength. As porosity is increased, the structural strength is reduced.

Pavers are generally suitable for pedestrian areas and low traffic parking areas. They are available in a variety of configurations such as rigid concrete or durable plastic grid filled with gravel or a mixture of gravel, sand, and topsoil suitable for vegetation.

Pervious pavement shall be designed only as an impervious area reduction technique to manage direct rainfall. It shall not be designed as a SMF that receives runoff from surrounding areas.

### **Site Requirements**

Surface slope no greater than 6 percent.

Site does not receive high sediment loads. Areas with high volumes of leaf litter can cause clogging, so avoid pervious pavement under large trees.

Adequate separation from underlying seasonal high groundwater table; bedrock or other impermeable layer shall be at least 3 feet below the bottom of the pervious pavement facility.

Pervious pavement is not appropriate for areas at elevated risk of hazardous materials spills such as gas stations.

Minimum infiltration rate of 0.25 in/hr.

Not appropriate for construction over fill soils unless evaluated and approved by geotechnical engineer.

No stormwater run-on allowed.

Pavement design shall demonstrate that pavement structure has the structural strength for anticipated vehicle loadings.

### **Dimensions**

Pervious pavements designed with 6 inches of aggregate storage and a minimum design infiltration rate of 0.25 in/hr are assumed to meet the performance standard to fully infiltrate the 10-year, 24-hour Design Storm.

Pervious concrete wearing course: 4-inch thickness for residential driveway, pedestrian only, private street, parking lot or fire lane; 7-inch thickness for public street. Public streets shall be designed in conformance with the local roadway authority.

Porous asphalt wearing course: 2.5-inch thickness for residential driveway or pedestrian paths; 3 inches for private street, parking lot, or fire lane; 6 inches for public street. Public streets shall be designed in conformance with the local roadway authority.

Pavers shall be designed according to manufacturer recommendations. State size of stone to be used between pavers—sand is not allowed if pavers are used for stormwater treatment or flow control.

Where pervious pavement installations are proposed over fine sediments, provide a 1- to 3-inch-thick leveling course if the pervious pavement surface is open-celled paving grids, interlocking concrete pavers, or porous asphalt concrete.

Minimum depth for aggregate storage reservoir shall be 6 inches for vehicular loading. In addition to structural design considerations, design depth is typically determined by storage depth needed to manage design storm.

Pervious pavements designed with 6 inches minimum of  $\frac{3}{4}$ -inch to 2-inch crushed/washed open graded base material and a minimum design infiltration rate of 0.25 in/hr are assumed to meet the performance standard to fully infiltrate the 10-year, 24-hour Design Storm.

### **Materials**

Leveling course: The leveling course shall consist of uniformly graded, washed aggregate that conforms to AASHTO No. 8 gradation.

Aggregate storage reservoir: The aggregate storage reservoir shall conform to ODOT Standard Specifications 00430.11 granular drain backfill material, AASHTO No. 57, or approved equal.

Porous asphalt: The surface wearing course for porous asphalt shall conform to open-graded,  $\frac{1}{2}$ -inch or  $\frac{3}{4}$ -inch asphalt concrete pavement design from ODOT Standard Specification 00745 or approved equal.

Content: 6.0 to 6.5 percent by weight of total (dry aggregate) mix. Performance Grade: 70-22. Do not use an asphalt cement performance grade less than 70-22 for open-graded, porous asphalt mixes.

### **2.6.5.13 Green Roofs**

A green roof is a building roof that is partially or completely covered with vegetation and growing media, atop a waterproof membrane; a green roof is also called an eco-roof or vegetated roof. Green roofs include the following elements: a thin, layered system of waterproofing, drainage layers, growing media, and planting to cover impervious roof areas and allow water to be absorbed, detained, and evaporated back into the atmosphere. Proprietary systems are also available using various layers or even modular trays that fit easily on an existing roof.

Green roofs are primarily designed for stormwater management, with aesthetics as a secondary goal. Green roofs are not designed for foot traffic or recreation.

### **Site Requirements**

Flat or slightly sloped roofs on large institutional, commercial, or residential projects. Green roofs work on sloped roofs up to a maximum of 4:12 roof pitch without additional engineering—and can be steeper with intermediate structural support of soils.

### **Structural Considerations**

Shall be able to carry additional loads as determined by a structural engineer (15 to 30 pounds per square foot is typical) to support fully saturated conditions.

These load recommendations do not include snow load.

Access to roof via crane, lift or other device is recommended to load heavy, and bulky materials up to rooftop surface.

Safety line tie-off points, hand holds, or walking surfaces may be necessary to facilitate maintenance.

Green roofs shall include outlets to an approved location from roof drains, scuppers, and other drainage devices.

### **Dimensions**

Green roofs may be designed to meet flow control and water quality performance standards.

The Developer's Engineer is required to provide adequate documentation showing how the planned green roof meets OLWS performance standards for flow control and water quality treatment Materials.

Root barrier/protection layer. A synthetic, non-biodegradable layer shall be placed to protect waterproofing layers and to provide additional protection from roots. Do not use copper or copper hydroxide for a root inhibitor.

Drainage layer/filter fabric. A synthetic or mineral layer shall be placed over the protection layer to allow for water movement under the growing media. The drainage layer shall be ½-inch-deep with a void space of at least 50 percent, covered by a non-woven (needle-punched) filter fabric to separate the drainage layer from the growing media.

Growing media. An engineered growing media mix shall be placed over the filter fabric to a depth of at least 4 inches to meet requirements. It shall contain no fines, weed seeds, or other materials. Provide documentation of saturated weight (field moisture capacity) that has been tested and documented by a third party. The media mix shall consist of 80 to 90 percent pumice or lightweight aggregate and 10 to 20 percent composted, plant-based organic matter.

Mineral mulch. A mulch layer of washed gravel or non-decomposable material (no fines) that will not be moved by wind or water movement shall be placed on top of the growing media.

Planting. Establish dense plant growth of low-maintenance, low-water use succulent vegetation supplemented with some hardy perennials, grasses, and other native, non-woody vegetation. A minimum of 10 species shall be included to promote microclimatic diversity and resilience to the roof, allowing for species to fill in if others are slow to perform. Use 10 percent deciduous species distributed throughout the roof to provide

organic matter inputs through leaf litter. Plant selection shall follow the Planting Guide in Appendix B.

Proprietary systems may not match these dimensions or materials.

## **2.7 STORMWATER DRAINAGE SYSTEM DESIGN**

---

Stormwater system design is an integral component of site planning. Acceptable stormwater drainage system design must strive to maintain compatibility and minimize interference with existing drainage patterns; control onsite and downstream flooding of property, structures, and roadways for design flood events; and minimize the potential environmental impacts of stormwater runoff. Three considerations largely shape the design of these systems: public safety, flooding, and water quality. Stormwater collection systems must be designed to provide adequate surface drainage while at the same time meeting other stormwater management goals such as water quality treatment, stream channel protection, wildlife habitat protection, and groundwater recharge.

Some sites may require two separate stormwater drainage systems: the localized onsite system and the regional bypass system. The onsite system is generally designed to convey stormwater runoff from the developed areas of the site to the SMFs. The SMFs discharge to the bypass system, which conveys upstream stormwater runoff around or through the developed site and conveys the stormwater to the natural point of discharge downstream. This section includes requirements for stormwater drainage system design.

### **2.7.1 General Conditions**

This section presents design requirements for open channel and closed conduit stormwater drainage systems. It also describes requirements and methods used to plan, design and size stormwater drainage systems. Stormwater drainage systems are generally made up of four components; stormwater runoff entering the site from upstream drainage areas; stormwater runoff conveyed through the site; the acceptable point of discharge from the site; and stormwater runoff discharged downstream from the site.

### **2.7.2 Stormwater Drainage System Requirements**

Planning for the stormwater drainage system is an essential element in preparing a site plan. Several factors must be considered prior to developing the preliminary design and requesting OLWS approval of the Service Provider Letter.

Stormwater drainage systems are to be designed to intercept and convey stormwater runoff efficiently enough to meet flood protection criteria. The stormwater drainage system should complement the ability of the site design and structural stormwater controls to mitigate the major impacts of urban development.

#### **2.7.2.01 Points of Discharge**

The Applicant will establish a proposed point of discharge. A point of discharge shall be approved by OLWS prior to approving the Service Provider Letter.

Runoff from developed portions of the site drainage area should be discharged at the existing natural drainage outlet or outlets.

Runoff must be discharged in a manner that will not increase flooding to downstream properties.

The Applicant will be responsible for acquiring approval from any other agency having jurisdiction or permitting authority related to the activity. OLWS may require a copy of other jurisdictional approval(s) prior to approving the plan.

If the point of discharge is an open stormwater drainage system, then adequate velocity dissipation and/or additional channel protection shall be required to prevent erosion and/or alteration to the existing downstream drainageway.

Any connection to a public or private piped downstream stormwater drainage system shall be approved by Clackamas County Department of Transportation and Development. Oak Lodge may require a copy of this approval prior to approving the plan. OLWS.

### **2.7.2.02 Onsite Stormwater Drainage System**

The site shall be planned and designed to generally conform to onsite natural drainage patterns and discharge to natural drainage paths within a drainage area. These natural drainage paths should be modified as necessary to contain and safely convey the peak flows generated by the development.

Open channel systems are preferred over closed conduit stormwater sewers where feasible, especially where they might provide opportunities for water quality treatment, some infiltration, wildlife habitat improvement, or emergency overland flood relief routes.

It shall be the responsibility of the Owner to provide a stormwater drainage system for all stormwater runoff and/or or surface water entering the property from offsite. Surface water, springs, and groundwater shall be incorporated into the drainage design.

An emergency overflow pathway must be identified and/or designed that allows large flow events to discharge without risk of injury or property damage. The emergency overflow pathway must be incorporated into the design and show how flow will escape from the site during rainfall events larger than the design storm events and/or from failure of the primary stormwater drainage system. Any emergency overflow pathway structures shall be designed for the 100-year Design Storm. The pathway location shall be co-permitted by Clackamas County DTD.

It is important to ensure that the onsite stormwater drainage system is designed to reduce blockages and flows in excess of the design storm capacity to minimize the likelihood of nuisance flooding or damage to private properties. If failure of these systems and/or drainage structures occurs during these periods, the risk to life and property could be significantly increased.

### **2.7.2.03 Upstream Drainage Areas**

Developments are required to convey upstream drainage through or around the development in a system OLWS refers to as a “Bypass System”.

The upstream offsite stormwater or other nuisance surface water runoff will be conveyed through the development in a separate system referred to as the “Bypass System” and will not be mixed with the stormwater collected and treated with onsite SMFs unless the SMFs are designed to include all of the additional flows from the upstream drainage areas(s) assuming full development potential.

The bypass system shall be designed according to Clackamas County DTD specifications.

It is important to ensure that the bypass stormwater drainage system is designed to reduce blockages and flows in excess of the design storm capacity to minimize the likelihood of nuisance flooding or damage to private properties.

If failure of these systems and/or drainage structures occurs during rainfall events in excess of the design storm capacity, the risk to life and property could be significantly increased.

In establishing the layout of stormwater networks, it is essential to ensure that upstream flows will not be redirected onto private property during rainfall events up to the stormwater drainage system design capacity.

### **2.7.2.04 Downstream Analysis**

Downstream analyses are required and reviewed by Clackamas County Department of Transportation. Full infiltration of the 10-year design storm or adherence to OLWS flow control performance standard (see Section 2.6.1.02) is intended to provide hydraulic mitigation and may remove the need for downstream analyses subject to Clackamas County’s approval.

## **2.7.3 Stormwater Drainage System Design Methods**

The following section describes accepted criteria and methods for analyzing and designing stormwater drainage systems. It is the responsibility of the engineer to determine the appropriate method of analysis in determining the capacity of the proposed stormwater drainage system.

### **2.7.3.01 Design Methodology**

Stormwater drainage systems shall be designed and constructed to carry the design storm flowing full with no pressure flow. Flow conditions in existing pipe systems will be evaluated by Clackamas County DTD.

Stormwater drainage systems in the Public ROW shall be designed per Clackamas County DTD standards.

## 2.8 CONSTRUCTION REQUIREMENTS

---

All development, regardless of permit status, shall keep sediment laden water and any other forms of stormwater pollution from entering natural drainage systems or the stormwater drainage system. The requirements for erosion prevention and sediment control shall be implemented in accordance with OLWS's Rules, these Standards, and the most current version of the Water Environment Services Erosion Prevention and Sediment Control Planning and Design Manual referentially adopted by OLWS. The Applicant for a development permit shall submit an EPSC Plan as part of their application specifying appropriate BMPs. For site disturbances of 5 acres or larger, the Applicant must demonstrate that they also have an DEQ-approved 1200-C permit.

The Applicant for a development permit is ultimately responsible for retaining all soil on the project site and must recognize the potential for changing, or unexpected site and weather conditions. If at any time the OLWS approved EPSC Plan is determined to be ineffective, OLWS will require additional controls to be implemented until a site is stabilized. The Applicant is responsible for updating the EPSC Plan and resubmitting it to OLWS.

### 2.8.1 General Provisions

The following general erosion prevention and sediment control provisions apply to all properties within OLWS' boundary, regardless of whether that property is involved in a construction or development activity.

- A. The use of erosion prevention techniques, including proper site planning and construction phasing, shall be emphasized, rather than sediment control measures. Erosion and sediment control practices shall be designed and implemented to maintain water quality; protect fish and wildlife habitat; maintain natural vegetation; reduce the use of pesticides, fertilizers, chemicals; and manage dust.
- B. Construction within waterways shall be pursuant to permits issued by State and Federal agencies having jurisdiction and shall apply their regulations. Pollutants such as, but not limited to, fuels, lubricants, asphalt, concrete, bitumens, raw sewage, and other harmful materials shall not be discharged into rivers, wetlands, streams, impoundments, undisturbed buffers, or any stormwater drainage system, or at such proximity that the pollutants flow to these watercourses.
- C. The use of water from a stream or impoundment, wetland, or sensitive area, shall not result in altering the temperature or water quality of the water body in violation of OARs, and shall be subject to water rights laws. All sediment-laden water from construction operations shall be routed through sedimentation basins, filtered, or otherwise treated to remove the sediment load before release into the surface water system.
- D. Construction shall be done in a manner to minimize adverse effects on wildlife and fishery resources pursuant to the requirements of local, state, and federal agencies charged with wildlife and fish protection.



- E. Natural Vegetation
  - a. As far as is practicable, natural native vegetation shall be protected and left in place. Disturbed Areas shall be carefully located and marked to reduce potential damage.
  - b. Trees shall not be used as anchors for stabilizing working equipment.
  - c. During clearing operations, trees shall not be permitted to fall outside the Disturbed Area. In areas designated for selective cutting or clearing, care in falling and removing trees and brush shall be taken to avoid injuring trees and shrubs to be left in place.
  - d. Where natural vegetation has been removed, or the original land contours disturbed, vegetative ground cover shall be planted and established in accordance with the Wet Weather Stabilization standards in Section 2.8.2.06.
- F. The use of hazardous chemicals, including pesticides, insecticides, herbicides, defoliant, soil sterilant, and fertilizers, must strictly adhere to Federal, State, County, and local restrictions.
- G. All pesticides, fertilizers, and chemicals delivered to the job site shall be covered and protected from the weather. None of the materials shall be exposed during storage. Waste materials, rinsing fluids, and other such material shall be disposed of in such a manner that pollution of groundwater, surface water, or the air does not occur. In no case shall toxic materials be dumped into drainageways.
- H. Dust and other particulate matters caused by development activity containing pollutants may not settle on property and/or be carried to Waters of the State through rainfall or other means. Dust shall be minimized to the extent practicable as per Section 2.8.6.05.

## **2.8.2 Erosion Prevention and Source Control Requirements**

This section provides criteria regarding erosion prevention and sediment control standards. The requirements of this section shall apply to all activities requiring an EPSC Permit. The Applicant for the EPSC Permit shall be responsible for meeting these requirements.

### **2.8.2.01 Erosion Prohibited**

Visible or measurable erosion as defined in OLWS's Rules, which enters, or is likely to enter, the public or private stormwater and surface water system or other properties, is hereby prohibited, and is a violation of these standards, unless authorized by a state or federal permit or certification.

Unless authorized by a State or Federal permit or certification, no person shall create physical erosion by dragging, dropping, tracking, or otherwise placing or depositing, or permitting to be deposited, mud, dirt, rock, or other such debris upon a public street or into any part of the public stormwater and surface water system, or any part of a private stormwater and surface water system which drains or connects to the public stormwater and surface water system. Any such deposit of material shall be

immediately removed using hand labor or mechanical means. No material shall be washed or flushed into any part of the stormwater and surface water system until all mechanical means to remove the debris have been exhausted and preventative sediment filtration is in place. The Applicant of the property, Permittee, under a site development permit, together with any person or persons, including but not limited to the Contractor or the Developer's Engineer who causes such erosion, shall be held responsible for violation of these standards.

#### **2.8.2.02 Erosion Prevention and Sediment Control Plan**

An EPSC Plan shall be prepared in accordance with the requirements of Section 2.8.4 of these standards for all sites where an EPSC Permit is required.

#### **2.8.2.03 Erosion Prevention and Sediment Control Permits**

The Applicant for a development permit shall submit an EPSC Plan as part of their application specifying appropriate BMPs.

An EPSC Permit is required under the following conditions:

- A. Prior to placement of fill, site clearing, or land disturbances, including but not limited to grubbing, clearing or removal of ground vegetation, grading, excavation, or other activities, any of which results in the disturbance or exposure of soils covering an area of 500 sf or greater.
- B. For Disturbed Areas or exposed soils of areas less than 500 sf, where OLWS has determined that site conditions may result in visible and measurable erosion and where OLWS has provided written notice of the requirement to obtain an erosion prevention and sediment control permit to the Owner. Upon notice by OLWS, all work shall cease pending receipt of an EPSC Permit and installation of approved EPSC measures.
- C. For any lot that includes natural resources regulated by OLWS, an EPSC Permit may be required prior to placement of fill, site clearing, or land disturbances, including but not limited to grubbing, clearing or removal of ground vegetation, grading, excavation, or other activities, any of which has the potential for, or results in visible and measurable erosion, regardless of the area of disturbance.

An EPSC Permit shall not be issued for activities on lots that include natural resources, where the site activity has not been authorized, or is not exempt under the provisions of Natural Resources as determined by OLWS. This provision does not apply where the EPSC Permit is associated with correction of a violation of OLWS Rules or Standards or as necessary for public safety, or the protection of property or water quality.

#### **2.8.2.04 NPDES 1200-CN and 1200-C Permit**

In addition to an OLWS EPSC Permit, a NPDES 1200-CN permit is required for projects disturbing one acre up to less than 5 acres of disturbance. The 1200-CN shall be issued by OLWS along with the local permit.

For disturbances of 5 acres or greater, a DEQ 1200-C permit is required. The local permit may also be issued by OLWS. The 1200-C permit shall be obtained directly from DEQ. In the case of a residential subdivision, the “child lots” created with the subdivision may be required by OLWS to obtain individual ECSL permits.

#### **2.8.2.05 Maintenance and Removal of Stormwater Best Management Practices**

The Permittee shall maintain the BMPs contained in the approved EPSC Plan to continue to be effective during the construction phase, post construction phase, establishment of permanent vegetation, or any other permitted activity. If the BMPs approved in an EPSC Plan are not effective or sufficient as determined by OLWS site inspection, the Permittee shall submit a revised plan within three (3) working days of written notification by OLWS. Upon approval of the revised plan by OLWS, the Permittee shall immediately implement the additional BMPs included in the revised plan. In cases where erosion is likely to occur, OLWS may require the Applicant to install interim control measures prior to submittal and/or approval of the revised EPSC Plan.

Temporary BMPs, such as sediment fences, shall be removed after permanent vegetation is established.

#### **2.8.2.06 Wet Weather Stabilization**

Where natural vegetation has been removed, or the original land contours disturbed, vegetative ground cover shall be planted and within 72 hours of completion of ground-disturbing project phasing established by October 1 and continue to function through May 31 of the following year, or as approved by OLWS. If ground cover is not established by October 1, the open areas shall be protected through May 31 of the following year with straw mulch, erosion blankets, like hydroseed, or other methods approved by OLWS. The site shall be revegetated per a submitted and approved seeding and maintenance plan as soon as practicable after construction has commenced, but not later than September 1. After that date, a stabilization plan approved by OLWS must be used.

#### **2.8.2.07 Contaminated Soils**

In the event the construction process reveals soils contaminated with hazardous materials or chemicals, all parties shall stop work immediately, ensure no contaminated material is hauled from the site, remove work forces from the immediate area of the contamination, leaving all machinery and equipment, and secure the area from access by the public until such time as a response team has evaluated the situation and identified an appropriate course of action. The Applicant and the Contractor shall notify OSHA and DEQ of the situation upon discovery. The Applicant and the Contractor must comply with OSHA and DEQ statutes and rules.

### **2.8.3 Establishing Protective Vegetative Cover Upon Completion of Final Grading**

To prevent and minimize erosion, all development shall implement BMPs as required by the EPSC requirements in these Standards including, but not limited to, the following stages of a project:

- A. Vegetation is to be established as soon as practicable after completion of final grading to minimize erosion.
- B. Prior to final project acceptance, the site shall be permanently stabilized with approved cover or permanent landscaping.
- C. In cases of a land division, temporary groundcover will be accepted on each lot where home construction will begin within 30 days of project completion.
- D. To the extent practicable, all stormwater facilities and open channel stormwater drainage system shall be permanently stabilized prior to use.
- E. Erosion control measures shall be continued after construction has been completed until the permanent stabilization measures and vegetative ground cover for the site is established and functioning such that erosion has ceased.
- F. The Developer will be responsible for all erosion prevention and sediment control for individual lots until ownership has changed.
- G. In cases with developments with 1200-C permits, the Permittee is responsible for erosion prevention and sediment control until the 1200-C permit is terminated by the state.
- H. Temporary EPSC measures shall be removed by the Developer when permanent stabilization or landscaping has been installed and is functioning.

### **2.8.4 Plans Required**

An EPSC Plan shall be prepared in accordance with the requirements of the most current version of the Water Environment Services Erosion Prevention and Sediment Control Planning and Design Manual and these Standards for all sites where an EPSC Permit is required. See Appendix A for submittal requirements.

### **2.8.5 Supplemental Plans**

This section provides criteria for supplemental plan submittals.

#### **2.8.5.01 Mass Grading and Runoff Control**

A phased mass grading and runoff control plan is required for projects where clearing and mass grading activities are proposed during Wet Weather. The runoff control plan shall identify BMPs from Section 2.8.6.03, or approved alternatives, and be submitted with, or as a revision to, the EPSC Plan. All stormwater BMPs specified on the runoff control plan shall be in place and functional prior to commencement of mass grading.

### **2.8.5.02 Dewatering**

A dewatering plan is required for projects with anticipated excavation activities at or below the ground water table, or if ground water is encountered during construction. The supplemental plan shall be submitted with, or as a revision to, the EPSC Plan and shall identify how dewatering discharges will be managed.

### **2.8.5.03 Cement Treatment**

A cement treatment plan is required for projects where cement treatment is proposed as a soil amendment (including, but not limited to Portland cement-treated base [CTB], cement kiln dust [CKD], or fly ash). The supplemental plan shall indicate an application rate, work schedule, and limits of work areas proposed for cement treatment. If cement treatment will occur during Wet Weather, the following conditions will also apply:

- A. The project shall be phased in small manageable areas to minimize the risk for erosion.
- B. Contractor shall have sufficient erosion prevention stormwater BMPs on site to cover all exposed soil.
- C. Each phase must be stabilized with temporary or permanent erosion prevention stormwater BMPs before disturbing additional phases.
- D. The plan shall indicate how runoff from areas treated with cement will not cause or accelerate erosion of soils not treated with cement.
- E. If the runoff has a high pH (8.5 standard units or higher) then the plan must include an engineered sediment basin or similar impoundment must be used for treatment before discharge. The operator is required to determine the acceptable pH water quality criteria range of site discharge based on criteria of the receiving waterbody according to OAR 340-041-0021. If necessary, the operator must adjust or neutralize the high pH water until it is in the range of pH Standard Units (SU) using an appropriate treatment BMP such as carbon dioxide (CO<sub>2</sub>) sparging or dry ice. The operator must conduct and document pH monitoring of stormwater captured in the sediment impoundment as described below:
  - a. The operator must begin the pH monitoring period when the engineered soils are first exposed to precipitation and must continue every 7 calendar days and within 24 hours of the occurrence of discharge from the site, or the occurrence of a storm event of 0.10-inches or greater until final stabilization of the area of engineered soils is established.
  - b. Document date soil amendments were added and final stabilization achieved in the Inspection Reports.
  - c. The operator must monitor the pH of stormwater in the sediment basins/impoundments and at discharge point locations that receive stormwater runoff from the area of engineered soils before the stormwater

discharges to surface waters. Testing shall be done by an approved method and protocol and be performed by an operator knowledgeable in the testing method.

- d. The benchmark value for pH is defined in SU and determined by the river basin containing the receiving waterbody according to OAR 340-041-0021. Anytime monitoring indicates that the pH is the maximum allowed SU or greater, the operator must either:
  - i. Prevent the high pH water from entering stormwater sewer systems or surface waters; or
  - ii. If necessary, adjust or neutralize the high pH water until it is in the range of pH SU acceptable for discharge to the river basin containing the receiving waterbody by using an appropriate treatment BMP such as carbon dioxide (CO<sub>2</sub>) sparging or dry ice. The operator must obtain written permission from OLWS (and/or other authorities as applicable) before using any form of chemical treatment other than CO<sub>2</sub> sparging or dry ice.
- F. If visible or measurable erosion is occurring, all cement treatment activities shall be suspended, and approved erosion prevention facilities shall be applied to all exposed soil.

#### **2.8.5.04 Chitosan Treatment Systems**

Chitosan treatment plan is required where chitosan is proposed as a BMP. The supplemental plan must include a statement of the intent to use chitosan, the reason for its use and the name, experience and training of the qualified operator who will be monitoring the use of chitosan. Additional requirements are dependent on the form of chitosan proposed, as detailed below:

- A. If chitosan acetate is proposed, the system must be a chitosan enhanced sand filtration system. The supplemental plan must demonstrate that the system is consistent with the protocol outlined in Ecology's GULD for chitosan enhanced sand filtration.
- B. If chitosan lactate (cartridge) is proposed, the system shall be designed by a registered PE to meet site specific conditions and comply with the manufacturer's recommendations. A supplemental plan must include the following:
  - a. Location and design schematic of treatment system, location of inlet and location of discharge and dispersion device design.
  - b. Method for ensuring filtration or settlement of treated stormwater to comply with the following discharge standards:
    - i. Residual chitosan must not exceed 1 mg/L,
    - ii. Turbidity must not exceed DEQ's Water Quality Standards, and

- iii. pH must remain within a range of 6.5-8.5
- C. Qualified operator inspection and certification of consistency with the design, prior to system operation and use.
- D. Testing and monitoring protocol, including at minimum:
  - a. Qualified operator must field test discharge using a Residual Chitosan Lactate Field Screening Test Kit, or OLWS approved equal.
  - b. Field tests shall be performed during the first discharge of treated water and weekly thereafter for as long as chitosan is being used.
- E. Response protocol, if field testing demonstrates exceedance of discharge standards, including immediate notification to OLWS, modification to the treatment system, and implementation of additional erosion control facilities.
- F. Notification protocol to OLWS if any modifications to the treatment system are made.
- G. Maintenance protocol of treatment system

## **2.8.6 Best Management Practices**

This section provides a list of approved stormwater BMPs. Each BMP shall be implemented consistent with additional information in the Standard Details from the most current Water Environment Services Erosion Prevention and Sediment Control Planning and Design Manual.

Depending on site-specific conditions, the required base measures may be inadequate to prevent erosion and control sediment discharges. In these cases, additional stormwater BMPs shall be applied to the site to meet the EPSC standards.

### **2.8.6.01 Base Measures**

The following stormwater BMPs, as described in Table 7, shall be implemented on all sites requiring an EPSC Permit:

- A. Gravel construction entrance/exit.
- B. Linear barrier or downslope perimeter control (e.g., sediment fence, straw wattles, or similar measure).
- C. Stormwater drain inlet protection
- D. Applying temporary or permanent soil stabilization to denuded development site areas in conformance with the following requirements:

Between October 1 and April 30, all denuded sites must be provided with either temporary or permanent soil stabilization as soon as practicable, but in no case more than two days after ground-disturbing activity occurs.

Between May 1 and September 30, all denuded sites must be provided with either temporary or permanent soil stabilization as soon as practicable, but in no case more than seven days after ground-disturbing activity occurs.

### 2.8.6.02 Erosion Prevention Stormwater BMPs

Erosion prevention is the highest priority in the overall EPSC Plan and shall be integrated into a project throughout the planning, design, scheduling, and construction phases. Erosion prevention stormwater BMPs shall be included in the approved EPSC Plan. See Table 7 for approved erosion prevention facilities.

Table 7. Erosion Prevention Stormwater BMPs

| Name                            | EPSC Manual Standard Detail | Description   |
|---------------------------------|-----------------------------|---|
| Preserve Natural Vegetation     | NA                          | Maintain existing vegetation or place vegetative buffer strips. This SMF is especially effective for sites with sensitive resources like wetlands, stream corridors, lakes, and steep slopes.   |
| Buffer Zone                     | NA                          | An undisturbed area or strip of natural vegetation or an established suitable planting adjacent to a Disturbed Area that reduces erosion and runoff. A Vegetated Corridor shall not be used or considered a buffer zone under this section.   |
| Temporary and Permanent Seeding | NA                          | Vegetative cover established on Disturbed Areas to reduce erosion by seeding (applied by hand or hydroseeding) with appropriate and rapidly growing grasses. Permanent seeding can be used in conjunction with erosion control blankets and mats to provide both temporary and permanent erosion prevention control.  |
| Ground Cover                    | NA                          | A protective layer of straw or other suitable material applied to the soil surface. Various ground cover methods include straw mulch and compost blankets.  |
| Hydraulic Application           | NA                          | A mechanical method of applying erosion control materials, other than simply hydroseeding, to bare soil. This BMP is often called Bonded Fiber Matrix. Bonded Fiber Matrix can be used without seed in upland areas to stabilize and prevent erosion. This BMP cannot be used in areas of concentrated flow or water quality facilities. This BMP may be used in place of straw, mulch, compost, or matting depending on site and weather conditions. |
| Sod                             | NA                          | Permanent or temporary turf for immediate erosion protection and stabilization.   |
| Matting                         | 4-1 and 4-2                 | A class of products that includes manufactured mulch materials that are produced in a roll configuration that is placed on the ground and held in place by stakes, metal staples, geotextile pins, or other fastening system. Matting shall be 100% biodegradable fibers or approved equal. Refer to the Floodplain, Wetland and Stream Construction Strategies Handbook for a comparison of matting types for work in sensitive areas.               |
| Soil Binders                    | NA                          | Materials that are applied to the soil surface for dust control and temporary erosion control. These are also known as hydraulic soil stabilizers.  |
| Stockpile Management            | 4-3                         | Methods to reduce or eliminate loss of sediment from temporary stockpiles of soil.  |



|              |    |  |
|--------------|----|--|
| Dust Control | NA | Water applied over susceptible areas, typically due to dry soil conditions, during high wind periods. (Also see Section 2.8.6.05). |
|--------------|----|--|

### 2.8.6.03 Runoff Control Stormwater BMPs

The purpose of runoff control BMPs is to control stormwater runoff and drainage patterns at construction sites. Runoff control BMPs shall be included in the EPSC Plan. Table 8 provides a list of approved runoff control BMPs.

*Table 8. Runoff Control Stormwater BMPs for All Sites*

| Name                    | EPSC Manual Standard Detail | Description   |
|-------------------------|-----------------------------|---|
| Pipe Slope Drain        | 4-9                         | The pipe slope drain carries concentrated runoff down steep slopes without causing gullies, erosion, or saturation of slide-prone soils. It should be designed to intercept and direct surface runoff or groundwater into a stabilized watercourse, trapping device, or stabilized area.  |
| Outlet Protection       | 4-7 and 4-8                 | Outlet protections are physical structures that reduce the velocity and energy of concentrated flow to prevent scour at stormwater drainage system outlets. Outlet protection includes riprap-lined basins, concrete aprons, and stilling basins.   |
| Surface Roughening      | 4-10 and 4-11               | Soil surface is roughened by mechanical methods. All slopes prepared by surface roughening shall meet engineering compaction requirements. This BMP is intended to only affect the surface of soils and is not intended to compromise slope stability or overall compaction.  |
| Check Dams              | 4-4 and 4-5                 | Small, temporary dams placed across a natural or man-made channel or drainage ditch and designed to reduce drainage ditch erosion caused by stormwater runoff by reducing the velocity of flow in the ditch. Check dams are often used as a temporary measure while a channel is being permanently lined with vegetation or other materials to prevent erosion. |
| Diversion Swale or Dike | 4-6                         | A ridge of compacted soil or a vegetated lined swale located at the top, base or somewhere along a sloping Disturbed Area.  |

### 2.8.6.04 Sediment Control Stormwater BMPs

Sediment control BMPs include any practice that traps soil particles after they are dislodged and moved by wind, water, or mechanical means. These BMPs are usually passive systems that rely on filtering or settling particles out of the water or wind once they have become suspended. Soil that accumulates in or near sediment control BMPs is a waste product that must be removed and disposed of at an approved location. Uncontaminated sediment/soil can be placed back on site and protected with appropriate erosion control BMPs.

Sediment control BMPs are considered the last line of defense before stormwater runoff leaves a site and are not to be used as the primary methods for EPSC.

Table 9 lists approved sediment control BMPs. These BMPs are to be applied prior to and during earthwork. Sediment control BMPs shall be included in the approved EPSC Plan.

The perimeter sediment barrier identified in Table 9 is not required where:

- A. Flows are collected through the use of temporary or permanent grading or other means such that the flows are routed to an approved settling pond, filtering system, or sediment control BMP.
- B. There are no concentrated flows, slopes are less than 10 percent, and runoff passes through a grass area which is either owned by the Applicant or such use is allowed, through written agreement, by the Applicant of the grass area. The grass area shall be at least equal in dimensions to the project area. The grass area shall not be located in a Vegetated Corridor or Sensitive Area.
- C. The surface is protected by re-established permanent vegetation.

Table 9. Sediment Control Stormwater BMPs

| Name                                  | EPSC Manual Standard Detail | Description  |
|---------------------------------------|-----------------------------|--|
| Gravel Construction Entrance/Exit ❶   | 4-13                        | Gravel construction entrances/exits shall be required at each entrance/exit to and from the site. If a property contains or is adjacent to a stream, watercourse, stormwater facility, wetlands, or other water quality sensitive area, BMPs in addition to a gravel construction entrance/exit shall be required to prevent physical erosion into the water quality sensitive area. |
| Tire Wash Facility                    | 4-26                        | The wheel wash, which shall be incorporated with a stabilized construction entrance, shall be designed and constructed for anticipated traffic loads.  |
| Linear Barrier or Perimeter Control ❶ | 4-23                        | Linear barrier (sediment fence) shall be installed around the down-gradient perimeter of the site to control sheet flow from the site. Sediment fence shall not be placed in areas of concentrated flow or across stream channels.   |
| Wattles                               | 4-27                        | Wattles are small, cylindrical barriers composed of biodegradable fibers encased in photodegradable open-weave netting. Wattles are placed in shallow trenches and staked along the contour of newly constructed or disturbed slopes.  |
| Storm Drain Inlet Protection ❶        | 4-15 through 4-20           | Temporary inlet protection shall be provided for all active inlets for the duration of construction to keep sediment, trash, and other construction-related pollutants out of the stormwater drain system.   |
| Rock or Brush Filter Berm             | 4-14                        | Rock or brush filter berms are temporary barriers composed of brush, wrapped in filter cloth, and secured or rock anchored in place. These are designed for sheet flow, not concentrated flow, and shall not be placed across a stream or channel.   |
| Sidewalk Subgrade Gravel Barrier      | 4-25                        | Undercut lots or sidewalk subgrades with rock base are linear drainage barriers that provide an effective sediment filtration and retention area behind the curb. If weep holes exist, they must be plugged when using this BMP.   |
| Dewatering                            | NA                          | Separation of sediment and water achieved through filtration, either by gravity or with pressure.  |

|                          |      |  |
|--------------------------|------|--|
| Sediment Trap            | 4-22 | A sediment trap consists of a small, temporary ponding area with a rock weir or perforated riser pipe at the outlet. This BMP is not to be used for drainage areas greater than 5 acres.   |
| Sediment Basin           | 264  | A temporary sediment basin has one or more inflow points and baffles to spread the flow for wet and dry storage. The sediment basin is effective for about one year with a drainage area less than 10 acres.   |
| Turbidity Curtains       | NA   | A turbidity curtain is a pre-manufactured floating geotextile structure which minimizes turbidity transport from a Disturbed Area adjacent to or within a body of water. This BMP can be used to minimize the mixing of turbid water with adjacent clean water and/or contain soil particles during construction and/or repair activities. |
| Sediment Entrapment Mats | 4-21 | This is a flat layered pad that provides filtration and settling of sediment. BMP may be incorporated into the permanent stabilization/revegetation process if used in conjunction with mulch and/or seed.   |

① These measures are minimum requirements for all projects per Section 2.8.6.01.

### 2.8.6.05 Dust Control Stormwater BMPs

During active project work, dust shall be minimized to the extent practicable, using all measures necessary, including, but not limited to the following BMPs.

- A. Sprinkling the haul and access roads and other exposed dust producing areas with water.
- B. Application of dust palliatives on access and haul roads as approved by OLWS.
- C. Establishing temporary vegetative cover.
- D. Placing wood chips or other effective mulches on vehicle and pedestrian use areas.
- E. Maintaining the proper moisture condition on all fill surfaces.
- F. Pre-wetting cut and borrow area surfaces.
- G. Use of covered haul equipment.

### 2.8.6.06 Non-Stormwater Pollution Control Stormwater BMPs

For the purposes of this section, non-stormwater pollution includes, but is not limited to, concrete truck wastewater, paint, fuel, hydraulic fluid, solvents, glues, and other waste materials characteristic of construction sites. Non-stormwater pollutants are prohibited from entering a public or private street or stormwater system or surface waters.

Non-stormwater pollution controls consist of general site and materials management measures that directly or indirectly aid in minimizing the discharge of sediment and other construction related pollutants from the construction site.

Approved non-stormwater pollution control BMPs include:

- A. Concrete truck washout areas.
- B. Written spill prevention and response procedures.

- C. Employee training on spill prevention and proper disposal procedures.
- D. Protected areas for equipment storage and maintenance where the risk of pollution is minimal.
- E. Debris boxes to contain construction wastes.

## **2.8.7 Inspection Requirements**

This section provides criteria for EPSC inspections during a project's construction.

### **2.8.7.01 Pre-Construction Conference**

Prior to the initial EPSC inspection, OLWS may require, or the Permittee, Applicant, or Contractor may request, a pre-construction conference to review and discuss the EPSC Plan for the site.

A pre-construction conference shall be required when the risk of erosion is high due to one or more of the following factors:

- A. Construction during Wet Weather.
- B. Steep slopes with severe erosion potential.
- C. Construction adjacent to a sensitive area or vegetated corridor.
- D. Mass grading on a large site.

### **2.8.7.02 OLWS Initial EPSC Inspection**

On all projects, except single family home construction sites, EPSC base measures shall be installed by the Permittee and then inspected and approved by OLWS's Inspector prior to the start of any permitted activity.

For single-family home construction sites, EPSC measures for each property shall be installed by the Permittee and then inspected and approved by OLWS's Inspector prior to the building foundation installation. Foundation approvals shall not be given until EPSC measures are approved.

### **2.8.7.03 Permittee Inspections**

The Permittee or Applicant's authorized agent shall provide ongoing inspection of the site in accordance with approved plans to ensure compliance with the standards specified in this section. The Permittee or Applicant's authorized agent for inspections shall be knowledgeable in EPSC BMP selection, installation, and maintenance. They shall also possess the technical skills to assess conditions at the construction site that could impact stormwater quality, and to assess the effectiveness of EPSC BMPs selected. If the Permittee or representative determines the stormwater BMPs approved in the EPSC Plan are not effective or sufficient to ensure compliance, additional stormwater BMPs must be implemented and identified in a revised plan.

For single family developments that disturb 1 acre or greater and all non-single-family developments the Engineer’s Inspector shall:

- A. Meet the applicable DEQ qualifying inspection certifications.
- B. Inspect the site once every 14 calendar days and within 24 hours of any storm event, including snowmelt, that results in discharge from the site.
- C. Maintain records of their EPSC inspection and maintenance activities. Records shall be made no later than 48 hours after inspection by the Permittee or their authorized agent. Records shall be made available to OLWS Inspector upon request.

For single family developments that disturb less than 1 acre, the Permittee’s or representative shall:

- A. Inspect the EPSC measures and provide maintenance as required to maintain the functionality of the BMP measures.
- B. Inspect site daily when stormwater runoff, including runoff from snow melt, is occurring, once per week on active sites when runoff not occurring or once every two weeks on inactive sites
- C. Keep onsite documentation of their EPSC activities for reference during operations, maintenance activities, and inspections.

#### **2.8.7.04 Final Inspection**

A final erosion control inspection shall be required on all sites after they have been stabilized and prior to approval of the Certificate of Occupancy. All temporary BMPs shall be removed prior to final inspection.

For single family sites seeking final erosion control inspection between September 1 and May 31, groundcover, using approved techniques, shall be completed before the single-family site can be deemed complete.

## **2.9 OPERATION AND MAINTENANCE**

---

The purpose of OLWS’s O&M requirements is to assure long-term operations and maintenance of public and private SMFs.

The O&M requirements in this section apply to all SMFs constructed as a requirement of OLWS’s Rules. Maintenance activities, such as routine maintenance, restorative maintenance, and rehabilitation are required to ensure the long-term function and effectiveness of SMFs and infrastructure. Initial site planning must incorporate provisions for adequate access and space to perform maintenance activities for all SMFs.

### **2.9.1 General Requirements**

All SMF designs will be held to the same maintenance standards regardless of the organization or entity that has accepted responsibility for the maintenance.

Privately maintained SMFs only convey Private Stormwater that generally benefit one owner or entity. They include residential, multi-family, commercial, and industrial types of developments. These SMFs require a maintenance covenant recorded with the title that describes the types of facilities and necessary maintenance.

## **2.9.2 Operations and Maintenance Plans Required**

All SMF that are intended to be privately maintained require the Developer, Applicant, or Owner to execute and record an O&M Plan prior to final inspection approvals of the related development permits. The O&M Plan shall ensure that Owner maintains and operates the SMF to preserve and continue its function. O&M Plans require Owners of property with SMFs to properly maintain, repair, modify or reconstruct (if necessary) the facility, and provide a schedule for the maintenance frequency for the facility.

### **2.9.2.01 Operations and Maintenance Plan Development**

O&M Plans shall be required for all permanent SMFs to ensure that they function as designed. The purpose of an O&M Plan is to provide guidance to those who are responsible for the long-term inspection and maintenance of the facility.

To ensure functionality of the SMFs, Owners are required to inspect facilities regularly per the approved O&M Plan to determine maintenance needs. Routine inspection and maintenance can help to keep overall maintenance costs low by detecting problems early and avoiding large repair or replacement costs.

The facility design and maintenance specifications in Appendix B can be used to create the O&M Plan. If the proposed facility types do not match the SMFs in Appendix B, the Applicant and Developer's Engineer will be responsible for creating any drawings, maintenance specifications, and an inspection checklist to be incorporated into the O&M Plan.

O&M Plans for privately owned/maintained facilities shall be recorded with the Recording Office of Clackamas County as an exhibit to the maintenance covenant referenced in Section 2.9300 before issuance of a building permit or final plat approval.

### **2.9.2.02 Operations and Maintenance Plan Elements**

The following outline can be used to prepare an O&M Plan.

#### **Introduction and General Information**

Facility information, including type and identifying name or number, as applicable. Include the number of each type of structure including the manufacturer's model number where applicable.

Name and contact information for the organization or individual responsible for conducting maintenance and/or ensuring maintenance is conducted.

Written narrative overview describing the site, drainage areas, and intended function of the facility.

### **Operations and Maintenance**

Normal operating procedures for facility function, including any seasonal modifications, adjustments, and manufacturer's recommendations.

Required regular maintenance activities and schedule (e.g., landscape maintenance, sediment removal, pipe cleaning).

Required inspection frequency to verify facilities are being maintained and functioning as designed.

Minimum maintenance standards that are required for the SMF to produce desired results and maintenance actions when the minimum standards are not met (See Appendix B). Where applicable, the minimum maintenance standards should include manufacturer's recommendations.

Expected lifespan of the facility components (i.e., the time when Owners should expect to replace growing media, plantings, cartridges, and control structure elements). Proprietary facility lifespan information, if known.

List of interrelated or connected SMFs and description of how each facility works with the next one.

### **O&M Plan Responsibility**

Identify the person(s) or organization(s) responsible for inspections of SMFs.

Identify the funding source for maintenance.

### **Attachments**

Include a site plan to identify the location of the facility/facilities, sources of runoff entering each facility, and ultimate stormwater disposal point.

Include the SMF detail sheet(s) and O&M Plan and checklist(s) (when applicable, use details in Appendix C for reference).

Include a copy of the public maintenance agreement and/or private maintenance covenant that will be used to assign maintenance responsibility and/or to allow access for maintenance or inspection of the SMFs.

### **2.9.2.03 Operations and Maintenance Plan Review and Approval Process**

The O&M Plan and associated agreements, covenants, and easements will be reviewed as part of OLWS's overall plan review and approval process.

## **2.9.3 Privately Owned and Maintained Facilities**

Generally, SMFs that convey Private Stormwater that benefit a single Owner or entity shall be privately-owned and maintained. All privately owned and maintained SMFs require an O&M Plan that is reviewed and approved as part of the overall plan review process.

### **2.9.3.01 Maintenance Covenant for Private Stormwater Facilities**

Maintenance of all privately-owned SMFs shall be ensured through the creation of a formal maintenance covenant that must be approved by OLWS and recorded into the land record prior to final plan and/or plat approval. The O&M Plan, including scheduled inspections and regular maintenance activities, shall be referenced in the maintenance covenant.

### **2.9.3.02 Access Easement**

Prior to the issuance of any permit that includes a SMF, the Applicant or Owner of the site must execute a maintenance covenant that includes public access rights, to inspect the facility and ensure that it is maintained in proper working condition. This includes the right to enter a property when OLWS has a reasonable basis to believe that a violation of OLWS standards and/or rules and regulations is occurring or has occurred, and to enter when necessary for abatement of a public nuisance or correction of an OLWS violation. The access easement shall be included in the maintenance covenant, as approved by OLWS, and recorded at the Recording Office of Clackamas County.

### **2.9.3.03 Annual SMF Inspection and Maintenance**

The Responsible Party identified within the O&M Plan shall complete and keep records of annual inspections of their SMF. The annual inspection records may be reviewed by OLWS upon request. All SMFs must undergo an annual inspection to document maintenance and repair needs and ensure compliance with the requirements of these standards. Maintenance needs may include, but not limited to the following: removal of silt, litter and other debris from all stormwater structures and facilities; grass cutting and invasive vegetation removal; and necessary replacement of water quality vegetation. Any maintenance needs identified must be addressed by the Responsible Party in a timely manner. The inspection and maintenance frequency may be increased as deemed necessary to ensure proper functioning of the SMF.

### **2.9.3.04 Records of Maintenance Activity**

Owners shall keep records of all SMF maintenance and repairs and shall retain the records for at least three (3) years. These records shall be made available to OLWS staff during inspection of the facility and at other reasonable times upon request. The Owner shall submit a copy of the SMF maintenance and inspection records to OLWS annually.

### **2.9.3.05 OLWS Inspection of Stormwater Management Facilities**

Inspections may be conducted by OLWS at any time, including but not limited to, routine inspections, random inspections, inspections based on complaints or other notice of possible violations, inspections related to OLWS's NPDES MS4 Permit, and joint inspections with other agencies done under environmental or safety laws. Inspections may include, but are not limited to, review of maintenance and repair records; sampling discharges, surface water, groundwater, or material/water in SMFs; and facility condition evaluations.



### **2.9.3.06 Failure to Comply with the O&M Plan**

If an SMF becomes a danger to public safety or public health, OLWS shall notify in writing the party responsible for maintenance of the SMF. Upon receipt of the written notice, the responsible person shall have 30 days, unless otherwise specified by OLWS, to complete the necessary maintenance and repair of the facility in an approved manner. If a responsible party fails or refuses to meet the requirements of the maintenance covenant, OLWS, after reasonable notice, may correct a violation of the design standards or maintenance needs by performing all necessary work to return the facility to proper working condition. If the Owner does not comply with their O&M Plan, after proper notice, OLWS shall assess the Owner of the facility for the cost of repair work and any penalties.

### **2.9.3.07 Modifications to the Operations and Maintenance Plan**

If it is determined that the O&M Plan requires modification to maintain the functionality of the facility, then modifications to the O&M Plan shall be submitted to OLWS for review and approval. Written approval from OLWS is required prior to modifying the O&M Plan. The approved modified plan shall be recorded at the Recording Office of Clackamas County.

## **2.9.4 Publicly Owned and Maintained Facilities**

Generally, publicly owned and maintained SMFs convey Public Stormwater, serve multiple properties, or provide drainage for the general public. Publicly owned SMFs can serve any type of development (residential, multi-family, commercial, industrial). Publicly owned facilities may be constructed by OLWS, or they may be constructed by private parties, with maintenance responsibilities OLWS determined by Clackamas County DTD.

END OF SECTION

## Appendix A PERMITTING AND SUBMITTAL REQUIREMENTS

---

Appendix A outlines the planning, plan review, and project completion requirements for both sanitary and stormwater sewer projects and is included in both the Sanitary Standards and the Stormwater Standards. This section is intended to standardize the submittals and clearly outline the minimum requirements. The requirement for a complete submittal package is intended to reduce the overall plan approval processing time.

### Review and Permitting Requirements

The following is a generalized overview of OLWS development review and permitting processes. This process may vary from one application, submittal and/or building permit to another and is only shown as a general outline of procedures and processes involved in the review and approval of projects located within OLWS. To obtain further information on a specific plan review or permit process contact a Development Review staff member. The Developer / Owner shall have ultimate responsibility for compliance with all requirements specified in these Sanitary Standards and OLWS's Regulations. The Developer / Owner shall be directly responsible for all administrative requirements including application for service, submittal of all required Plans, bonds and insurance, and payment of fees.

#### General Plan Review and Approval Process

This subsection describes the most common elements of the general development review process for a typical partition, subdivision, multi-family, commercial or industrial project. Applicants should discuss their project with OLWS and local planning authority early to understand the review and approval process required for a specific project.

1. **Pre-Application Conference** – The Applicant may elect to meet with the local planning authority, OLWS, and other related departments to discuss the proposed project to better understand the potential requirements. It is best if the Applicant submits a preliminary concept or plan, so OLWS is better prepared to discuss the proposed development. Contact the local planning authority to schedule the pre-application meeting. The planning authority will invite OLWS to the meeting.
2. **Service Provider Letter (Feasibility Statement)** – Applicants proposing to develop or redevelop property shall obtain a Service Provider Letter from OLWS prior to submitting the land-use or design review application to the local planning authority.
3. **Water Quality Resource Area Boundary Verification** – If applicable, prior to OLWS issuing a Service Provider Letter, the local planning authority must approve a WQRA Boundary Verification for vegetated buffer requirements (see the Buffer Standards).
4. **Conditions of Approval** – The local planning authority will process the land use/design review application and route a copy of the application for OLWS review. OLWS will review the application and submit comments to the local planning authority to be included as conditions.

5. **Jurisdictional Authority**– If the proposed project is outside the service area boundaries of OLWS, the Developer must petition for annexation to OLWS. The annexation must be approved by the Board before final occupancy or plat approval. The Applicant shall submit a complete annexation packet to OLWS prior to any plan approvals by OLWS. (There may also be de-annexation procedures.)
6. **Pre-Design Meeting** – The Applicant may elect to coordinate a meeting with the local planning authority and/or OLWS to discuss the project and requirements outlined in the conditions.
7. **Plan Submittal** – Upon land use approval, the Applicant must submit required fees, civil plans and supporting documentation as specified in these standards for plan review and approval.
8. **Other approvals** – Other permits and approvals may be required prior to OLWS approving the plans (i.e., County, City, State or Federal).
9. **Approved Plan(s)** – Plans and applicable building permit applications will be reviewed, approved, and then signed by an authorized representative of OLWS. If applicable, it may be necessary to hold a Pre-Construction Meeting with the Developer’s Engineer, Contractor, Applicant, OLWS, and other related agency representatives to discuss project requirements, including processes to complete the project as specified in the Sanitary, Stormwater and Water Engineering Agreements.
10. **Construction** – The public sanitary and stormwater management infrastructure shall be constructed under the supervision of the Developer’s Engineer as specified in the Sanitary, Stormwater and Water Engineering Agreements.
11. **Construction Completed** – Upon final completion of the construction, the Developer’s Engineer will certify the project was constructed in accordance with the approved plans, and the as-built plans are an actual record of what was constructed.  
  
The following items will be completed and submitted prior to requesting the final inspection of the public sanitary and/or stormwater infrastructure:
  - i. All sanitary and/or stormwater infrastructure shall be cleaned of sediment and debris.
  - ii. Electronic copy of the as-built drawings shall be submitted.
  - iii. If applicable, submit the video testing of the public sanitary and stormwater conveyance piping systems, along with the Contractor’s reports for review and approval. The Developer’s Engineer shall review the video and reports, and note any deficiencies discovered in the system(s) prior to submitting the items to OLWS.
  - iv. Submit a copy of the Developer’s Engineer inspection reports if OLWS did not inspect the project/facility(ies).

12. **Final Inspection** – OLWS will review the required as-built submittals and, if acceptable, will schedule the final field inspection. All repairs and corrections shall be made prior to OLWS deeming the project complete.
13. **Final As-built Drawings** – When requested by OLWS, the Developer’s Engineer shall submit the corrected final as-built drawings, electronic CAD, and PDF files of the as-built civil construction plan set.
14. **Warranty Surety Inspection** – Between 11 and 12 months after issuance of the letter of completion and acceptance, OLWS will inspect the public facilities at the request of the Owner. The inspection will include all relevant stormwater treatment infrastructure, including the plantings and other related improvements. Once all deficiencies are corrected, OLWS will issue a release letter.

### **Service Provider Letter Submittal Requirements**

The intent of the Service Provider Letter is that, prior to applying for Land Use/Design Review, the Applicant must demonstrate the proposed development is viable in accordance with OLWS Rules and applicable Standards. The Service Provider Letter will only be issued once the Applicant has provided sufficient plans, reports, studies, and agency approvals needed for preliminary review by OLWS. Based on the preliminary review, OLWS may require additional information prior to issuance of the letter or as part of the forthcoming land use application. Receipt of the Service Provider Letter does not imply that all OLWS requirements have been met or guarantee that land use approval for the development will be granted.

Applicants must submit the following to OLWS for review:

- Preliminary plat (if applicable)
- Preliminary proposal for public and private sanitary infrastructure
- Proposed sanitary system layout, including compliance with minimum design standards
- Points of connection to public sanitary sewer system
- Service proposal for upstream properties
- Preliminary Stormwater Management Plan and Drainage Report
- Site assessment and maps
- Proposed stormwater drainage system and stormwater facilities:
  - Infiltration, detention, and water quality facilities
  - Conveyance System design
  - Point of discharge
  - Emergency overflow pathway
  - Service proposal for upstream properties
- Soils report and analysis
- Drainage area maps
- Infiltration testing results
- Drainage system analysis (upstream and downstream)

- Sizing and conveyance calculations
- Other supporting reports and information (as deemed necessary by OLWS)
- BMP Sizing Tool calculations
- WQRA Boundary Verification or Natural Resource Assessment
- Preliminary approval for off-site easements
- Offsite mitigation measures for downstream conveyance
- Statement that the same information was submitted to CC DTD for the any public ROW impervious surface changes or changes to the public infrastructure.

### **Land Use Submittal Requirements**

As part of the land use/design review application process, the Applicant must provide sufficient plans, reports, studies, and agency approvals needed for preliminary review by OLWS, as including, but not limited to the Service Plan Submittal Requirements, above. The Applicant’s materials shall include any additional information or revisions requested by OLWS with issuance of the Service Provider Letter.

The land use review stage includes OLWS issuance of 1) a Service Provider Letter, prior to land use application submittal, and 2) land use conditions of approval, following receipt of a complete land use application from the local planning agency.

### **Plan Review Submittal Requirements**

The Developer’s Engineer shall submit sufficient supporting information to indicate that the proposed plan design meets all the provisions within these Standards, including the land-use conditions. The submittal information shall include, but not be limited to, the items listed within this section.

#### Initial/First submittal requirements:

The following is a list of application submittals required by OLWS for a typical development:

- Water Quality Resource Area (WQRA) Boundary Verification and WQRA Development Permit, submit to the local planning authority as required (see Buffer Standards)
- Complete set of drawings for the Stormwater Management Plan
- Existing conditions
- Infiltration testing
- Proposed on-site stormwater drainage system and stormwater facilities
- Proposed grading plan
- Existing and proposed off-site improvements
- EPSC Plan
- Details and notes
- Stormwater Management Report that includes:
  - The engineered or BMP Sizing Tool method used to size the stormwater facilities.

- A Stormwater Drainage System/Hydrologic and Hydraulic Calculations Report
- Hydrology and hydraulic calculations with drainage area maps
- Tributary drainage areas shall be calculated in table form and identified on maps submitted with the report
- Geotechnical/Geologist Report
  - Infiltration Testing
  - Soils Report
  - Geology Report

Other submittal requirements required by OLWS as applicable prior to final plan approval.

- Standard Forms
  - Stormwater System Construction and Engineering Costs Data Sheet
  - Sanitary Sewer Construction and Engineering Costs Data Sheet
- Non-Residential Questionnaire Easements/Agreements as applicable
  - Public/Private Water, Sanitary and Stormwater Easements
  - Public/Private Stormwater Facility Operation and Maintenance Plan/Agreements

Periodically, OLWS may require additional information to support design assumptions used for sanitary sewer design. When required, the information shall be included on the Plans or submitted in memorandum form to OLWS. The following may be required:

- Potential size of drainage basin
- Number of potential EDUs

#### Sanitary Sewer Extension Submittal

The Public Sanitary Sewer Extension submittal shall include all required information along with any other information requested by OLWS. The required information includes, but is not limited to the following:

- Electronic Set of complete civil construction Plans.
- Construction and Engineering Cost Estimate.
- Sanitary Plan review fees.

All submittals will be reviewed for completeness and the Developer’s Engineer will be notified if required information is missing. Upon acceptance of a complete submittal, subsequent project review and approval steps shall be undertaken.

#### Partition/Subdivision Plat Review and Approval

The Applicant shall submit a preliminary plat to the local planning authority, who will coordinate plat review with OLWS. OLWS will only perform an official review of plats received from the local planning authority. OLWS will review the plat in accordance with the approved Water, Sanitary Plans and Stormwater Management Plans and return comments to the local planning authority. Prior to final plat approval by OLWS, the Developer shall address the following:

- All associated agreements and easements shall be reviewed and approved by OLWS. OLWS will deliver the signed documents to the County Surveyor's Office at the time of plat approval.
- Sanitary and Stormwater Improvements shall be:
  - Fully constructed in accordance with the approved plans, or
  - The Applicant shall obtain a performance surety for all proposed water, sanitary and stormwater improvements on the approved plan. If the construction work is partially completed, the surety will be based on a status report submitted by the Developer's Engineer.
- Public easement documents shall include a site plan and specify the entitlements within the boundary of the easement.
- Deferred Improvements – In some situations, the responsibility to construct improvements may be deferred to the future Owner of a specific lot. Deferrals are at the discretion of OLWS and will be reviewed on a case-by-case basis. All deferred improvement(s) shall be fully constructed and completed in accordance with the Rules and applicable Standards, prior to any future occupancy permit approvals by OLWS. All responsibilities of the future Owner to construct the deferred improvements shall be stipulated in a separate document recorded as a covenant with the plat.
  - Subdivision Plats – Any deferred improvements must be part of an OLWS -approved subdivision improvement plan.
  - Partition Plats – Eligible improvements are limited to Service Connections, Conveyance System, pervious surfaces, and stormwater facilities that either benefit one lot, or are shared facilities. In the case of shared facilities, the deferred improvements will be the responsibility of the first future lot Owner to submit a building permit application.
  - Other related agreements and documents (i.e., Homeowner's Association covenants, conditions, and restrictions; maintenance agreements, etc.)

### **Plan Submittals**

This section contains specific information and drawing specifications for submittals made to OLWS. This section is intended to standardize the submittals and clearly outline the minimum requirements. The requirement for a complete submittal package is intended to reduce the overall plan approval processing time. Plans will not be reviewed until a complete plan has been submitted. A complete plan shall include at a minimum all requirements listed in this section.

#### **A. Specific Sheet Submittal Requirements and Specifications**

The following sheets are required as part of a complete plan submittal:

- Title Sheet including OLWS's two inspector contact information and OLWS's inspection and review authority. These are contained in the application pre-application conference notes.
- Composite Utility Plan

- Composite Stormwater Management Plan Cover Sheet
- Stormwater and Sanitary Sewer Plans and Profiles
- Grading Plan
- EPSC Plan
- Vegetated Buffer Planting Plan
- Stormwater Management Facility Planting Plan
- Standard and Non-Standard Drawings/Detail Sheets
- Standard and Non-Standard Construction Notes
- All applicable Standard Drawings shall be included on a separate sheet in a clear and legible size.

## **B. Title Sheet**

As a minimum the following information shall be found on the title sheet:

- Index of Sheets.
- Complete legend of symbols used.
- Vicinity Map to a scale of not less than 1 inch = 800 feet showing the project location.
- Site Plan of the entire project showing street ROW and/or subdivision layout.
- Temporary and permanent benchmarks including their descriptions. Total acreage including streets directly served.

## **C. Composite Utility Plan**

The Composite Utility plan shall be scaled to show the entire site on one sheet unless otherwise approved by OLWS and shall show:

- All proposed sanitary and stormwater improvements
- All other proposed improvements
- All existing utilities and utilities adjacent to and within 100 feet of the project
- Existing natural or artificial drainage features
- Tract names and numbers
- Property lines with tax lot numbers and addresses
- Street names at a minimum shall be shown

## **D. Composite Plan Cover Sheet (separate sanitary and storm)**

The following information shall be included on the Composite Plan cover sheet:

- The scale shall be scale-appropriate to fit the entire site on one sheet, unless otherwise approved by OLWS
- Show the appropriate contour lines to demonstrate the overall site topography. Generally, these are 1-, 2-, 5-, or 10-foot contour lines. The topography must extend a minimum of 50 to 100 feet beyond the proposed limits of development
- Show the entire system
- Show the SMFs
- Shade all other utilities not related to sanitary sewer or stormwater drainage



systems.

- Show drainageway(s) as existing and/or proposed.
- Show emergency overflow pathway(s) to an acceptable point of discharge.
- Show existing and/or proposed stormwater drainage and conservation easements.
- Show vegetated buffers and associated sensitive areas.
- Show all site and roadway improvements.
- Show the subdivision, phase lines or plat boundaries.

## **E. Plan and Profile Views**

Plan and profile views shall include the following information:

### **Plan View**

Plan views shall contain as a minimum the following information:

- The scale shall be 1 inch = 50, 40, 30, 20 or 10 feet horizontal; whichever occupies the most drawing area on the sheet. Alternative scales may be approved by OLWS on a case-by-case basis. The scale shall be shown for each plan and profile view.
- Entire sanitary and stormwater sewers clearly shown and labeled.
- Plan views showing north predominantly to the top or left of each sheet.
- Plan views showing accurate 1- or 2-foot contour lines and extending a minimum of 50 feet to 100 feet beyond the limits of the development. Alternative contour spacing may be approved by OLWS on a case-by-case basis.
- All proposed extensions of the Conveyance Systems showing mainlines, manholes and Service Connections.
- Manholes identified and stationed to facilitate comparison of the plan view and the profile view.
- Size and type of pipe, backfill material, and location.
- Sanitary/Stormwater Service Connection tees off the mainline. For each lot being served, show the mainline stationing, pipe size, length, and depth of lateral at end of pipe.
- Public ROW, property, and easement lines.
- Location of water courses, stream and railroad crossings, culverts and stormwater drains that cross the alignment.
- Subdivision names, roadway names and lot/parcel numbers or tax lot numbers.
- Existing and proposed Sensitive Areas and the required Vegetated Buffer.
- Existing utilities, all manholes, water mains, services, gas mains, underground power, and other utilities and structures, including hydrants, pedestals, signs, mailboxes, light poles, wells, water mains, valves, pumps stations, and blowoff structures, manholes, valves, meter boxes, power poles, handicap ramps, striping, and trees.
- Existing and proposed edge of pavement on both sides of the street, including shoulders, curb, sidewalk, ditch line, culverts, and driveways.

- Plan view including the above items for a minimum distance of 50 feet to a maximum of 500 feet may be required beyond the proposed improvement in order to prevent future improvement conflicts.
- Location and dimensions of all SMFs, including the following:
  - Setbacks from property lines and structures,
  - Facility wall material, if required, and geotextile/waterproofing membrane specifications,
  - Growing medium specifications,
  - Drain rock and filter fabric specifications,
  - All stormwater piping associated with each facility including pipe materials, sizes, slopes, IEs at bends and connections,
  - Ground elevations at catchment locations, channel inverts, top and toe of slope surrounding detention/retention areas,
  - Ground slopes of channel inverts and sides, parking lots, bottoms and sides of facilities and adjacent surroundings,
  - Invert and top or bottom elevations (if applicable) of pipes, catch basins, overflows, manholes or other similar structures.
  - Location of construction fencing used to protect proposed SMFs from compaction and other construction disturbance.
- Location of all drainageways and the 100-year flood plain.
- Show the location and direction of any surface stormwater conveyance path(s).
- Location and detail of all existing facilities on which work is to be performed, i.e., installation, repair, or removal.
- Location and description of all known existing property monuments, including, but not limited to, section corners, quarter corners, donation land claim corners and any other county control monuments.
- Street stationing may be shown on the construction plans, but later removed on the final as-built plans.
- Roof drain connection points shall be shown using the ® symbol.
- Sanitary and stormwater structures should be easily visible and shown drawn at least 2x the size of the line width and in proportion to the line weight.

### **Profile View**

Profile views shall contain as a minimum the following information:

- Plan and profiles on each sheet shall match and line up on at least one edge of the drawing (i.e., profile to show pipe in same direction as the plan view and lined up plan view over profile).
- The scale shall be 1 inch = 50, 40, 30, 20 or 10 feet horizontal; whichever occupies the most drawing area on the sheet. Feet horizontal and 1 inch = 10 feet vertical, with station numbers aligning vertically on the same sheet. Alternative scales may be approved by OLWS on a case-by-case basis. The scale shall be shown for each plan and profile view.
- Location of existing and proposed manholes and other appurtenances with each

manhole numbered and stationed. Manhole numbers to be provided by OLWS, if applicable. Wastewater Manhole callouts shall be in OLWS format. The benchmark used as a basis for vertical control in the design shall be referenced on the plans.

- The location and elevation of an approved benchmark shall be shown on the plans or, if not within the proposed area of work, shall be referenced by number and location. Elevations shall be based on the NAD83 datum if the project is within ½-mile of a County benchmark. A conversion factor to relate the existing connection point elevations to the plan elevations and benchmark.
- Grid lines using the horizontal and vertical scale.
- Existing and proposed ground and/or pavement surface with elevations noted at critical points.
- Sanitary/Stormwater lines shall be labeled with the name of the mainline centered under the profile view in large bold letters.
- Sanitary/Stormwater lines shall be labeled with the pipe size, material, slope (as a %), length and type of backfill between manholes.
- Nonstandard manholes must be labeled with the type (i.e., tamperproof, drop, flat top, etc.).
- Railroad, culvert, ditch, or stream crossings with elevations of the ditch or streambed and casing details.
- All existing and proposed storm, water, and any other crossing utility lines greater than 6 inches in diameter.
- Non-standard SMFs and appurtenances shall show a typical cross-section with dimensions.

## **F. Grading Plan**

Projects requiring grading and/or fill activities will require the submittal and approval of grading plans prior to the beginning of such operations. OLWS will review the grading plan in the context of the overall Stormwater Management Plan. Generally, an additional grading permit and/or approval are required by the local authority or State agency governing such activities. It is the responsibility of the Applicant to obtain all necessary permits and approvals prior to beginning any grading activity.

Grading plan views shall contain as a minimum the following information:

- Total land area and proposed Disturbed Area,
- Existing topography and impervious area,
- Proposed topography and impervious area,
- 1-, 2-, or 10-foot contour intervals (as applicable),
- Elevations of all existing and proposed streets, alleys, utilities, sanitary and stormwater sewers, and existing buildings and structures,
- Natural or artificial drainageways,
- Limits of flood plains (as applicable),
- Existing and proposed slopes, terraces, or retaining walls,
- All existing and proposed SMFs, drainage structures and/or features, and devices

used to protect these areas during construction,

- All stormwater structures/features on-site, upstream, and downstream of the site,
- EPSC Plan (as applicable),
- Drainage calculations when required,
- Drainage easements when required,
- Geotechnical report (if applicable),
- Any other supporting documentation necessary to evaluate the existing and/or proposed site conditions for stormwater management.

#### **G. Erosion Prevention and Sedimentation Control Plan**

The general process and requirements for EPSC Plans is outlined in the Stormwater Standards. For specific details on erosion control BMP measures and applications see the Water Environment Services Erosion Prevention and Sediment Control Planning and Design Manual. A link to this manual can be found on OLWS website.

If a 1200-C or 1200-CN Permit is required, the EPSC Plan shall meet the requirements of the 1200-C Program, in addition to the following list:

- The total acreage of the site and the total acreage of the proposed Disturbed Area.
- Adjacent offsite drainage patterns indicated by arrows.
- Contours at 2-foot intervals. Where slopes exceed 15 percent, contours may be shown at 5-foot intervals.
- North arrow.
- Existing and proposed structures for the project site.
- Existing and proposed access location for the project site.
- Existing project boundaries, rights-of-way, easements, and jurisdictional boundaries clearly identified by note, symbol, or key.
- Adjacent streets with street names and ROW boundaries.
- Capacity and condition of existing drainage facilities, including roadside or other drainage ditches, that transport stormwater and/or surface water onto, across, or from the project site.
- Existing Sensitive Areas, vegetated corridors, and water quality and quantity facilities. For natural drainage features, show direction of flow, drainage hazard areas, and the 100-year floodplain.
- Clearing and grubbing limits.
- Proposed ground contours.
- For multi-phase projects, phasing of any EPSC work clearly indicated on the plan.
- Details of proposed EPSC BMPs.
- EPSC Plan to include a key signifying BMP measure used and placement on EPSC Plan.
- When sedimentation ponds are proposed, at least one cross section detail shall be shown.

- Vegetation/permanent site stabilization measures.
- If submitted independently of the full project plans, a cover sheet with the proposed name of the development, the name and address of the Applicant and Developer, the name and address of the Developer’s Engineer, and the land use case file number from the local planning authority.

#### **H. Vegetated Buffer Planting Plan**

If restoration of a Water Quality Resource Area or vegetated buffer is required in the Stormwater Standards, a plan addressing the requirements shall be submitted.

The construction plans and specifications shall include:

- Water Quality Resource Area and required vegetated buffer boundaries.
- The limits of any approved, temporary construction encroachment.
- Orange construction fencing noted at vegetated buffers as well as at encroachment limits during construction.
- Permanent type fencing and signage at the development and the vegetated buffer boundary noted and details shown.
- Conservation easement documents prepared and easement area shown on the plan.
- Site preparation plan and specifications, including limits of clearing, existing plants, and trees to be preserved, and methods for removal and control of invasive, non-native species, and location and depth of topsoil and or compost to be added to re-vegetation area.

Planting plans and specifications shall include the following information:

- Planting table that documents the common name, scientific name, distribution (planting zone, spacing, and quantity), condition and size of plantings, and installation methods for plant materials listed.
- Mulching rates.
- Plant tagging for identification noted.
- Plant protection methods.
- Seeding mix, methods, rates, and areas delineated.
- Irrigation plan and specifications, including identification of water source, watering timing and frequency, and maintenance of the system.
- Maintenance schedule, including responsible party and contact information; dates of inspection (minimum three per growing season and one prior to onset of growing season); and estimated maintenance schedule (as necessary) over the two-year monitoring period.
- “Good” rated corridor notes (i.e., invasive species removal shall be replanted with native vegetation).
- Access points for installation and maintenance, including vehicle access if available.
- Standard drawing details (north arrow, scale bar, property boundaries, project name, drawing date, Developer’s Engineer, and Owner).

## **I. Stormwater Management Facility Planting Plan**

The Stormwater Management Facility Planting Plan shall include planting information for each SMF based on requirements of the Stormwater Standards.

Planting plan specifications and plans must address all elements that ensure plant survival and overall SMF functional success. At a minimum, landscape specifications and plans must include:

- A planting plan that indicates existing vegetation to be preserved; protective construction fencing; the location of all landscape elements; and the size, species, and location of all proposed plantings. The plant species should be selected and placed in accordance with proper delineation and location of moisture zones where appropriate.
- A plant list or table that includes botanic and common names; size at time of planting; quantity; spacing; type of container; evergreen or deciduous; and other information related to the facility-specific planting in accordance with landscape industry standards. Also include the square footage of each plant zone and the numbers and types of each plant required and provided in each zone.
- A soil analysis for the SMF growing medium (required for all public facilities and may be required for private facilities. A soil analysis is not required for single-family residential sites). The source of the growing medium must be provided. The location of all stockpiles must be indicated on plans, and erosion protection measures included on the EPSC Plan.
- The method of temporary irrigation to be used for the plant establishment period.
- Stormwater Management Facility Planting Plan shall also include all areas requiring protective construction fencing to shield the area from construction traffic and compaction.

## **J. Landscape Plan**

Landscape plans for publicly maintained SMFs shall be prepared, stamped with the seal of, and signed by, a Landscape Architect, registered in the State of Oregon. Plans for privately maintained SMFs do not require the involvement of a Landscape Architect. Landscape Plans shall include the following detailed landscape plan, at a scale of 1-inch equals 20 feet shall be provided for each landscaped SMF. This plan may be combined with the grading plan. The landscape plan shall include the following:

- Existing vegetation to be preserved and protective construction fencing.
- Areas of SMFs to be designated with construction fencing to protect from construction traffic and compaction.
- Final ground contours at a minimum of a 2-foot contour interval.
- Location of top and toe of slope.
- Limits of embankment designed to impound water.
- Location of all drainage structures as well as any other piped utilities in the vicinity.

- Limits of areas to receive amended topsoil and growing medium.
- A plant list or table, including botanic and common names, size at time of planting, quantity, spacing, type of container, evergreen or deciduous, and other information related to the facility-specific planting, in accordance with landscape industry standards.
- Location of stockpiles (erosion protection measures must be shown on the EPSC Plan).
- Method of temporary irrigation to be used for the establishment period.
- Location of maintenance access, as applicable.

#### **K. Standard Drawings/Detail Sheets**

The construction plans shall include a sheet containing all the standard details applicable to a specific project.

The purpose of OLWS Standard Drawings and Details is to provide basic information as a convenience to those who use them in their designs. These drawings and details are also intended to communicate design standards and practices to the Developer's Engineer.

Detailed drawings shall be included with all construction plans where Standard Drawings do not apply. If a standard drawing, such as a manhole, must be modified to fit existing, or unique conditions, the modified detailed drawing shall be shown on the plan and profile sheet. When appropriate, due to required detail complexity, a separate detail sheet shall be used.

Standard Drawings are available for use on development projects and cannot be modified by designers on a project-by-project basis. It is the responsibility of the Developer's Engineer to incorporate these drawings as originally intended.

Non-standard detail drawings shall be the responsibility of the Developer's Engineer to demonstrate that site conditions require a non-typical device or structure and submit the specifications and supporting documentation to OLWS for approval. All non-standard details shall be shown on the Stormwater Management Plan.

Stormwater Management Facility Detail sheets are included in the Stormwater Standards. A link to additional Standard Details can be found on OLWS website.

#### **L. General Sanitary/Stormwater Construction Notes**

General construction notes required on the plans can be found on OLWS website or provided upon request. These general construction notes shall be included on the sanitary and Stormwater Management Plans. These notes are required, and the design professional may include other applicable notes they deem necessary.

#### **M. General Sheet Submittal Specifications and As-built Requirements**

The following subsections outline general submittal specifications for sheet size, scales, north arrow, text, labeling callout, and title block specification requirements.

##### **Sheet Dimension Requirements**

Construction plans shall be clear and legible and submitted on blue-line paper 22 by 34 inches or 24 by 36 inches in size with a 1½-inch clear margin on the left edge and ½-inch margins on all other edges.

### Title Block

Located on the bottom edge or at the right side of the drawing, showing the project name, drawing name/type, completed modification date table, the submittal date, drawing number, Developer’s Engineer’s name, address and official stamp, the Developer/Owner’s name and address and where applicable, the name of the plat of subdivision and/or name of development.

### Drawing Scale Requirements

The following general layout guideline shall be used:

- Plan and Profile sheets shall be 1 inch = 50 feet 40, 30, 20 or 10 feet horizontal; whichever occupies the most drawing area on the sheet. 1 and 1 inch = 10 feet vertical. OLWS may approve alternative scales on a case-by-case basis.
- Each sheet shall include a bar scale with text.

### North Arrow Requirements

Each sheet shall include a north arrow. Each separate view on each sheet shall have its own north arrow. The north arrow in each view should face the top (VERTICAL) on the sheet if possible. It is acceptable to align the north arrow off vertical if the project does not fit vertically facing north; it can be rotated counterclockwise as much as 90 degrees.

For acceptable north arrow angle directions see Figure 1.

Figure 1. North Arrow and Text Reading

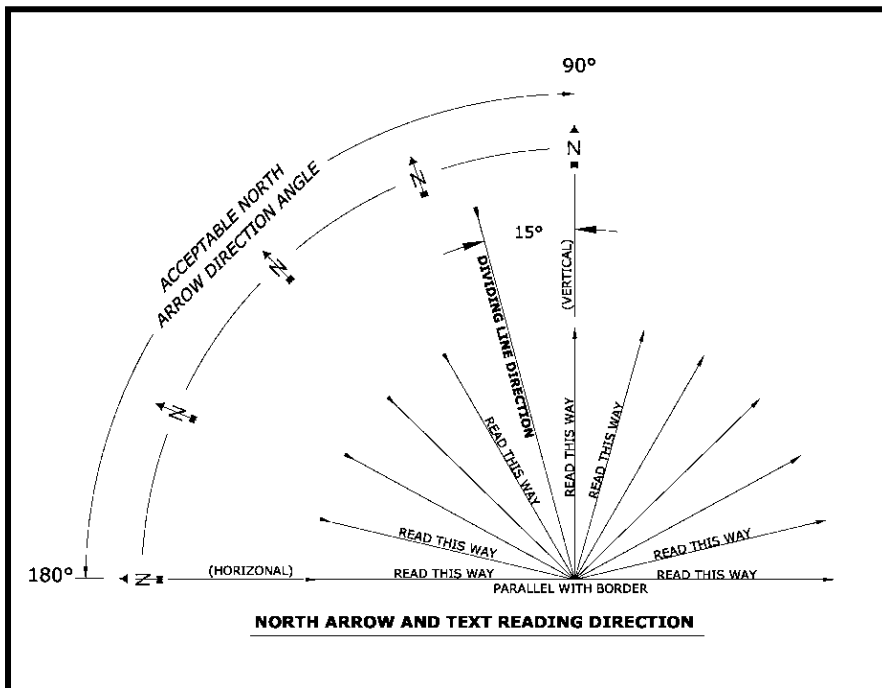



## Lettering/Text Requirements

- Text Rotation
  - Text should be readable from either the bottom or right edge of the sheet. For acceptable text reading direction, see Figure 1.
- Lettering Size and Style
  - Lettering Size
    - The minimum lettering size shall be eight-hundredths (0.08) of an inch high for existing items and a minimum lettering size shall be ten-hundredths (0.10) of an inch high for new items. Items shall be legible and reproducible.
  - Lettering Style
    - Standard text styles should be used. All lettering should be upper case.

## Labeling Requirements

- Sanitary and stormwater structures, proposed and existing, shall be labeled on each sheet.
- All street names are to be labeled in each model space window.
- All tax lots and easements within the development and surrounding area pertaining to the project shall be clearly labeled.
- Non-standard stormwater structures (e.g., Flat Top Manhole) shall be labeled with the unique structure type after the structure name.

## Plan and Profile Views-Structure and Pipe Callouts

### Plan View Leader Line Requirements (see Figure 2 and Figure 3)

- Leader lines must angle off horizontal and vertical planes from the center point of the structure in plan view. Horizontal and vertical leader lines are acceptable in profile view.
- Leader lines should have an arrow.
- The leader line arrow should touch the edge of the symbol and point to the center of the structure.

Figure 2 Accepted Leader Practice

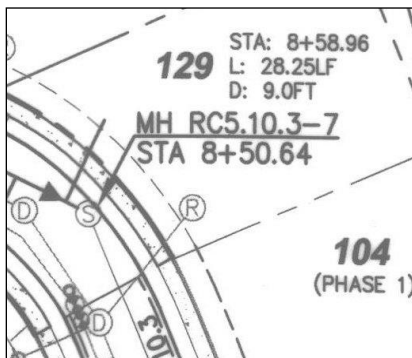
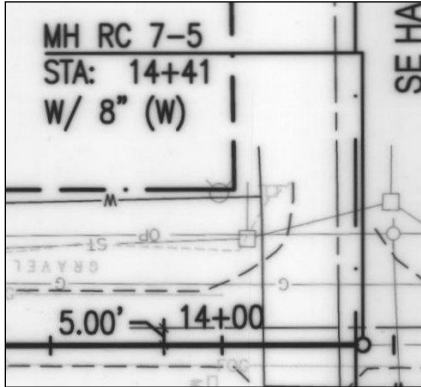

Figure 3 Not Accepted Leader Practice



General Sanitary/Stormwater Structure Callouts in Plan and Profile Views

Street stationing and other related information is allowed on the construction plans; however, this must be removed on the accepted as-built plans.

Plan View–Non-Typical Manhole Callout:

HV20-1, Flat Top  
 STA. 15+00

Plan View–Manhole Callout:

MH3B-2  
 STA 3+49.40

Plan View–Catch Basin and Other Structures:

CB 3B-1  
 STA 3+70  
 RIM 486.50  
 IE OUT 478.40 (8" N)  
 15.00 LF PVC, 12" Ø  
 @ S = 35.67%

Profile View–Manhole Callout:

MH3B-2  
 STA 3+49.40  
 RIM 486.50  
 IE IN 478.60 (10" N)  
 IE OUT 478.40(10" E)

Profile View–Catch Basin and Other Structures:

CB 3B-1  
 STA 3+70  
 RIM 486.50  
 IE OUT 478.40 (8" N)  
 15.00 LF PVC, 12" Ø

@ S = 35.67%

Profile View—Manhole Callout with Multi IE IN:

MH3B-2  
STA 3+49.40 =  
STA 0+00 STM 4  
RIM 486.50  
IE IN 478.60 (8"N)  
IE IN 478.60 (8"E)  
IE OUT 478 (8"S)



### Reference Balloons

In general, note reference balloons are not allowed. OLWS will determine the type and format of all callouts on the final as-built drawings if notes are included. If reference balloons are used on construction drawings then the structure name callout must precede the number as shown below in Figure 4.

Figure 4 Reference Balloon

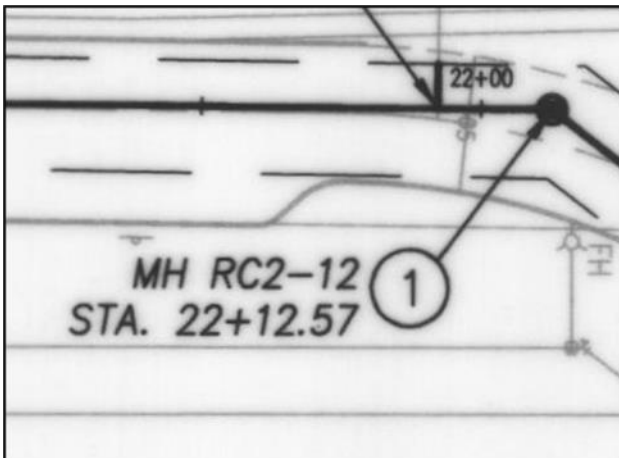

### Utility Crossings

Show and label all storm, sanitary, waterline, gas and all other utilities that are 6 inches or larger that cross the pipeline alignment in the profile view. Utility invert and crown elevations may be required if they are in close proximity to a proposed stormwater line. See Figure 5.

Figure 5 Utility Profile

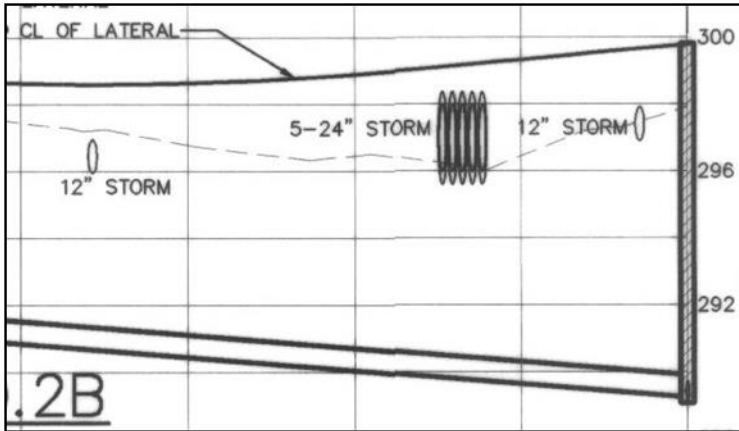

### Plan and Profile View Sheet Specifications

Plan and Profile Views shall contain the following information:

- Follow the Line Weight Guide for Drawing Submittals, Figure 6.
- Screening layers during plotting will not be permitted for any line types on plots except for widely spaced hatching. Screening lines are not allowed on as-built record drawings.
- The primary structures and pipes (storm) shall appear **BOLD** and stand out against all other background features in both the plan and profile views, i.e., only the applicable conveyance lines and appurtenances should appear bold on submittals.

Figure 6 Line Weight Guide

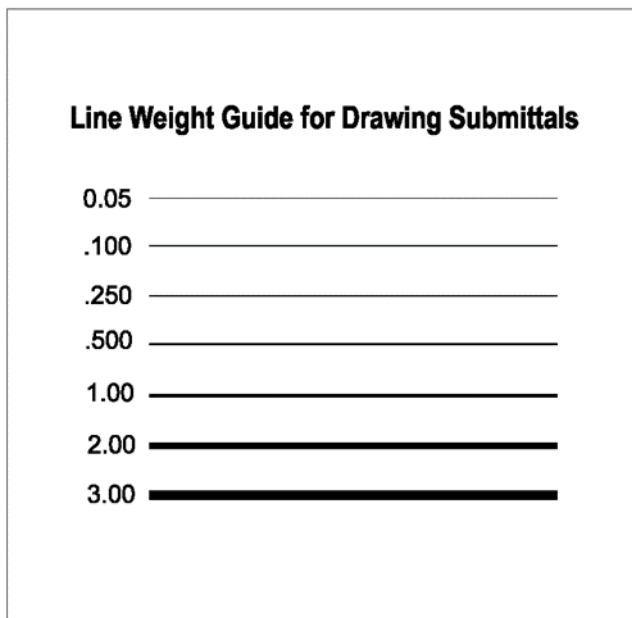

**Plotted Line Widths:**

Lines shall be plotted in millimeters and widths and plotted at 1 inch = 50 feet in model space and 1:1 in paper space. The line widths should be plotted the thickness of the lines as illustrated in Figure 6.

Screening of line weights is prohibited for illustration of line weights. Solid gray lines may be used in place of screening lines.

**Plan View:**

The plan and profile showing the proposed mainline extensions and Service Connections shall have a line weight of 3.00 millimeter (mm) (black). The sanitary or stormwater in the background shall have a width of 1.00 mm.

Existing contour lines in the plan view may be drawn as a dashed or solid line type; black or gray; between 0.250-0.500 mm in weight.

**Profile View:**

Profile view of the proposed system mainline shall be drawn at a line weight of 2.00 mm. Other utilities shown in the background shall be drawn at a line weight of 0.500 mm in either black or gray.

Existing sanitary/stormwater lines shall be shown in the profile view as a dashed black or a gray line in a line weight of 1.00 mm.

Other associated line specifications for plan and profile views:

Profile view gridlines:

- Primary – 0.250 mm/black
- Secondary – 0.050 mm/black
- Tax lots, parcels, property, and easement lines – 1.00 mm/black
- Roadway improvements – 0.500 mm/black
- All other utilities – 0.250 mm/black or gray
- Subdivision or plat boundary – 2.00 mm/black or gray

**As-Built Submittal Requirements**

OLWS requires the sanitary and stormwater plans shall be as-built prior to the acceptance of the project. As-built drawings are necessary to assure the project was constructed per the approved plans and/or meet the requirements of these Standards. The Developer's Engineer of record is responsible for record keeping, inspection, and preparation of the as-built drawings. Final as-built drawings will be submitted in the following manner, CAD files and PDF files.

**a) Survey requirements**

The following Public Sanitary System structures shall be surveyed, and the as-built elevation and location shall be noted on the final as-built drawings:

- i. I.E., ins, outs, and rim elevations of the:

- Point of connection, existing downstream manholes, and structures,
- Dead end manholes, cleanouts, and structures,
- Any manhole or structure that may be extended in the future,
- Any substantial change in the approved plans that deviate more than 0.250-feet in elevation or alignment.
  - A table listing the Service Connections for each building lot noting the mainline stationing, the measurement in linear feet of the location of the Service Connection from the center of the upstream and downstream manholes, pipe size, pipe length, and pipe depth at the property line crossing.
  - Show alignment changes, slope changes, IE changes, pipe size changes and changes in construction materials.
  - Measured depth from existing ground surface of all storm, sanitary, waterline and utilities that cross the pipeline alignment in profile.
  - Type of pipe, backfill material and location.

**b) As-built Drawing Requirements**

As-built drawings shall contain, at a minimum, the following information:

- For all publicly maintained systems and all public and private detention and SMFs, the Developer’s Engineer shall submit certified as-built plans and profile drawings.
- Each page shall be stamped by the Developer’s Engineer and stated in writing that it is an as-built drawing.
- Show final pipe alignment, slope, pipe size, and pipe material type in the appropriate view.
- Indicate areas of rock removal not completed by standard backhoe, i.e., splitter or blasting.
- As-built drawings and electronic drawings shall become the unencumbered property of OLWS and are public records that may be distributed as OLWS deems necessary.
- On the applicable Plan View sheet show a table listing the following information for each sanitary and/or stormwater Service Connection; mainline stationing, measurement in linear feet of the location of the Service Connection from the center of the upstream and downstream manholes, pipe size, pipe length, and pipe depth of the service lateral at the property line.
- Street stationing and information not related to the stormwater system construction is not allowed on the as-built plans; however, this information is acceptable on the construction plans.
- Remove all hatching associated with material type.
- The subdivision name shown in the title block shall match the name shown on the plat.

**c) CAD Requirements for As-Built Drawings**

#### General Requirements:

- Projected to NAD83
- AutoCAD electronic files must be compatible with the AutoCAD version OLWS is currently running.
- Standard fonts, shapes and line types are required.
- All drawings are to be plotted in paper space at a scale of 1:1.
- For specific line weight requirements see Figure 10.
- Show the project boundary in BOLD type.
- All manholes, catch basins, fire hydrants, valves, meters, etc. are to be inserted as blocks. All blocks are to be created on layer 0.
- Not allowed are blocked x-refs and preferences or permissions set, so that OLWS cannot access each layer individually.
- All drawings are to be seamless and drawn in model space.
- Drawings are NOT to be rotated off of world coordinate bases.
- Drawings are to be delivered purged of all unused layers, blocks, line types, and styles.
- The drawing files saved to disk shall be ready to plot when opened and be the same dated file used to plot the paper as-built.
- SoftDesk point files are not requested and should not be transmitted. Combination files are acceptable.
- The final as-built drawing files are to be saved under one file folder. All drawings, x-refs, plot files, images, text, and shape files are to be in this one file folder.
- Only pertinent files are to be submitted in this project folder. NO revisions, SoftDesk files, log times, or miscellaneous DWGs are to be submitted.
- Before approval will be given, the digital file and hard copy will be evaluated to verify that they are identical drawings and to make sure all required and only necessary files are included.
- The electronic as-built drawings shall be submitted along with a completed “As-built Release of Liability Form” and all contents shall become the property of OLWS.
- Provide the CAD as-built project drawings in digital data and saved to compact disk or flash drive for transmittal to OLWS or upload the file to the digital application.
- Use of a self-extracting PKZIP file format is acceptable. Use of compressed file(s) is allowed only if the decompression program is included.

#### Disks Labeling Requirements:

- Title of project
- OLWS (OLWS Log#) project file number
- Specify contents of the disk (DWGs)
- Name of the Developer’s engineering firm submitting the files
- The project completion date.

**d) PDF File Requirements for As-Built Drawings**

AutoCAD electronic files must be compatible with AutoCAD version OLWS is currently running.

As-built drawings and electronic drawings shall become the unencumbered property of OLWS and are public records that may be distributed as OLWS deems necessary.

The PDF files shall represent an exact copy of the paper as-built drawings.

Drawings shall be projected to NAD83.

**General Conditions for Performance And Warranty Surety**

OLWS may require the Applicant to submit a surety, cashier's check, or irrevocable letter of credit from an acceptable financial institution to guarantee performance or warranty in completion of the improvements required by these standards. Upon default, OLWS may draw upon the surety or available funds to complete the remaining work or remedy violations. The different types of acceptable surety are listed below.

**a) Surety – Types of Acceptable Guarantees**

Surety shall be provided only through State regulated surety companies while assignment or commitment of savings or loan proceeds shall be through State regulated financial institutions. Cash Acknowledgment is a cash surety held directly by OLWS.

**b) Surety Forms**

All sureties shall be submitted with forms provided by OLWS or other authority having jurisdiction to permit or regulate the activity. All sureties are subject to review and approval by OLWS's legal department.

**c) Performance Surety**

The Applicant shall provide a Performance Surety acceptable to OLWS prior to recording of the plat for residential developments or the issuance of building permits for commercial or industrial developments, if the required public improvements are not completed and/or accepted by OLWS.

The following conditions shall be met prior to acceptance of the Performance Surety:

- The Performance Surety shall be in the amount of 125 percent of the Developer's Engineer's cost estimate for all approved but uncompleted sanitary and stormwater improvements, including landscaping requirements. The Developer's Engineer's cost estimate for the required improvements will be approved by OLWS.
- Nothing herein shall limit the Owner's responsibility for repair and maintenance to the amount of the surety.
- The following conditions shall be met prior to release of the Performance



Surety:

- All improvements must be completed as shown on the approved plans and accepted by OLWS in accordance with the Rules, Regulations, and Standards.
- A warranty surety shall be provided to OLWS prior to release of the Performance Surety.

If the Applicant fails to comply with the conditions of approval and the approved plans, OLWS may call upon the Performance Surety to complete the improvements according to the approved plans.

At the end of the surety period when all conditions are satisfied, the residual surety amount shall be released.

**d) Warranty Surety**

In general, the Warranty Surety is posted by the surety principal to OLWS to ensure the principal will maintain, repair, replace and be responsible for damage to the improvements for a period of 2 years following the date OLWS deems the improvements complete and a letter of completion and/or acceptance is issued.

The following conditions shall be met prior to acceptance of the Warranty Surety:

- The Warranty Surety shall be in the amount of 25 percent of the actual constructed cost for all constructed sanitary, stormwater, and vegetated buffer vegetated buffers are covered in the warranty bond improvements. The Developer's Engineer's cost data sheet will be approved by OLWS.
- The Warranty Surety shall be in favor of OLWS and be issued for a minimum two-year period from the date of completion of the sanitary or stormwater system.
- Nothing herein shall limit the Owner's responsibility for repair and maintenance to the amount of the surety.
- Upon notification from OLWS, the principal shall complete corrective measures within 30 days to the satisfaction of OLWS.
- OLWS may perform emergency work without notice to the principal or surety.
- All work performed by OLWS due to the nonperformance of the principal or in response to an emergency shall be reimbursed to OLWS within 30 days of invoice.
- If the principal fails to reimburse OLWS in 30 days, OLWS may demand payment from the Surety.
- The warranty period may be extended, if the required improvements show any signs of failure during a final warranty release inspection.

The following conditions shall be met prior to release of the Warranty Surety:

- The Owner or Developer shall perform a thorough cleaning of all sanitary and stormwater improvements.

- OLWS shall make a determination of final completion in conformance with the approved plans, specifications, and OLWS standards as well as conduct a final warranty surety inspection of all sanitary and stormwater improvements, including landscaping in any SMF and vegetated buffer. If more than 20 percent of the total area within a SMF or Vegetated Buffer is not in compliance with the approved plans, then the vegetated plantings will be replanted and/or repaired to meet the requirements of the approved plans. If replanting of the SMF or Vegetated Buffer is required, then an additional 1 year warranty surety in the amount of 25% of the cost of replanting all of the effected vegetated planting areas shall be required. The additional 1-year warranty surety will be renewed annually until the vegetated plantings are acceptable to OLWS.
- Any deficiencies resulting in non-acceptance of the work permitted shall be identified in writing on a final punch list and presented to the Developer's Engineer and/or Permittee with a date named for correction and completion. Upon correction of the noted deficiencies and the determination that all work is in conformance with OLWS Standards, the work will be deemed complete and all sureties shall be released.

## **Infiltration Testing Requirements**

To properly size and locate SMFs, it is necessary to characterize the soil infiltration conditions at the location of the proposed facility. All projects that require a SMF shall evaluate existing site conditions and determine if the site's infiltration rate is adequate to support the proposed SMF. The following sections provide the approved methods for testing infiltration and setting the design infiltration rate. OLWS staff may require additional testing on a case-by-case basis.

### **Basic Method – Open Pit Test**

The Basic Method – Open Pit Test (Simplified Method) is applicable only to projects on private property with less than 10,000 sf of new or redeveloped impervious area. The results of infiltration testing shall be documented on either the City of Portland Simplified Form or the form in Table 11 below. The Basic Method cannot be used for projects that have known downstream conveyance problems.

The intent of the Basic Method is to determine whether or not the local infiltration rate is adequate (0.5-inches/hour) to support a SMF that infiltrates. It is recommended but not required that the Basic Method infiltration test be conducted by a licensed professional.

1. Conduct one test for each proposed SMF. The test should be where the facility is proposed or within the direct vicinity.
2. Excavate a test hole to the depth of the bottom of the infiltration system, or otherwise to four feet. The test hole can be excavated with small excavation equipment or by hand using a shovel, auger, or posthole digger.

3. If a layer hard enough to prevent further excavation is encountered, or if noticeable moisture/water is encountered in the soil, stop, measure, and record this depth from the surface. Proceed with the test at this depth.
4. Fill the hole with water to a height of about six inches from the bottom of the hole (or to one-half the maximum depth of the proposed facility) and record the exact time. Check the water level at regular intervals (every 1 minute for fast-draining soils to every 10 minutes for slower-draining soils) for a minimum of 1 hour or until all of the water has infiltrated. Record the distance the water has dropped from the top edge of the hole.
5. Repeat this process two more times, for a total of three rounds of testing. These tests should be performed as close together as possible to portray the soil's ability to infiltrate at different levels of saturation accurately. The third test provides the best measure of the saturated infiltration rate.
6. For each test pit required, submit all three testing results with the date, duration, drop in water height, and conversion into inches per hour.

If the results of the Basic Method show an infiltration rate greater than 0.5-inches per hour, the Applicant can proceed with SMF design that uses infiltration. If the Applicant would like to use an infiltration rate for design purposes, a Professional Method Infiltration Test shall be conducted.

### **Professional Method**

The Professional Method shall be used for all public and private developments with more than 10,000 sf of new or redeveloped impervious area. The Professional Method may be required by OLWS for a public and private development of any size with known downstream conveyance problems. The qualified professional shall exercise judgment in the selection of the infiltration test method.

### **Testing Criteria**

Testing shall be conducted or observed by a qualified professional. This professional shall be a PE, Registered Geologist, or Certified Engineering Geologist licensed in the State of Oregon.

The location and depth of the test shall correspond to the facility location and depth.

Infiltration testing should not be conducted in engineered or undocumented fill.

Boring logs shall be provided as supporting information with infiltration and depth to groundwater tests.

All testing data shall be documented in the project submittals. The submittals shall demonstrate that the proposed facilities are sized appropriately for the tested infiltration rates.

**Depth and Location of Required Tests**

Infiltration tests shall be performed at the base of the proposed facility.

If a confining layer, or soil with a greater percentage of fines, is observed during the subsurface investigation to be within four feet of the bottom of the planned infiltration system, the testing shall be conducted within that confining layer.

Tests shall be performed in the immediate vicinity of the proposed facility. Exceptions can be made to the test location provided the qualified professional can support that the strata are consistent from the proposed facility to the test location.

For relatively deep stormwater facilities, a hollow stem auger with an electronic measuring tape can be used, provided there is an adequate seal between the auger and the native soil.

**Factors of Safety**

Table 10 lists the recommended factors of safety to be applied to field-obtained infiltration rates for use in stormwater system design. To obtain the infiltration rate used in design, divide the infiltration rate measured in the field by the factor of safety. The factor of safety used in design should be chosen by collaboration between the geotechnical engineer or geologist overseeing the infiltration testing and the civil engineer designing the stormwater management system.

Determination of the factor of safety shall include consideration of project specific conditions such as soil variability, testing methods, consequences of system failure, complexity of proposed construction, and other pertinent conditions. The design infiltration rate after applying the safety factor shall not exceed 100 in/hr for non-vegetative facilities, such as drywells or infiltration chambers. Vegetated facilities with growing media shall be designed at a maximum infiltration rate of 6.0 in/hr through the growing media.

*Table 10. Infiltration Rate Safety Factors*

| Test Method               | Recommended Correction Factors                |
|---------------------------|---|
| Encased Falling head      | 3   |
| Open Pit Falling Head     | 2   |
| Double-Ring Infiltrometer | Public Facilities: 1<br>Private Facilities: 2 |

**Open Pit Falling Head Procedure**

The open pit falling head procedure is based on the EPA Falling Head Percolation Test Procedure (Onsite Wastewater Treatment and Disposal Systems Design Manual, EPA/625/1-80-012, 1980). The test is performed in an open excavation and therefore is a test of the combination of vertical and lateral infiltration.

1. Excavate an approximately 2-foot by 2-foot-wide hole into the native soil to the elevation of the proposed facility bottom. The test can be conducted in a machine-excavated pit or a hand-dug pit using a shovel, posthole digger, or hand auger. If smooth auguring tools or a smooth excavation bucket is used, scratch the sides and bottom of the hole with a sharp-pointed instrument, and remove the loose material from the bottom of the test hole.
2. A 2-inch layer of coarse sand or fine gravel may be placed to protect the bottom from scouring and sloughing.
3. Fill the hole with clean water a minimum of one foot above the soil to be tested and maintain this depth of water for at least 4 hours (or overnight if clay soils are present) to presoak the native material.
4. Percolation rate measurements shall be made after 15 hours and no more than 30 hours after the soaking period begins. It is important that the soil be allowed to soak for a sufficiently long period of time to allow the soil to swell if accurate results are to be obtained. Any soil that sloughed into the hole during the soaking period shall be removed and the water level shall be adjusted to six inches above the added gravel (or 8 inches above the bottom of the hole).
5. In sandy soils with little or no clay, soaking is not necessary. If after filling the hole twice with twelve inches of water, the water seeps completely away in less than 10 minutes, the test can proceed immediately.
6. The measurements should be made with reference to a fixed point. A lath placed in the test pit prior to filling or a sturdy beam across the top of the pit are convenient reference points. The tester and excavator should conduct all testing in accordance with OSHA regulations.
7. Measure the water level to the nearest 0.01-foot (1/8-inch) at 10-minute intervals for a total period of 1 hour (or 20-minute intervals for 2 hours in slower soils) or until all of the water has drained. At no time during the test is the water level allowed to rise more than six inches above the gravel.
8. Successive trials shall be run until the measured infiltration rate between two successive trials does not vary by more than 5 percent. At least three trials shall be conducted. After each trial, the water level is readjusted to the twelve inch level. Enter results into the Infiltration Test Data Table provided at the end of this section as Table 11.
9. The results of the last water level drop are used to calculate the tested infiltration rate. The final rate shall be reported in inches per hour. See the

calculation following the Infiltration Test Data Table provided at the end of this section.

10. For very rapidly draining soils, it may not be possible to maintain a water head above the bottom of the test pit. If the infiltration rate meets or exceeds the flow of water into the test pit, conduct the test in the following manner:
  - a. Approximate the area over which the water is infiltrating.
  - b. Using a water meter, bucket, or other device, measure the rate of water discharging into the test pit.
  - c. Calculate the infiltration rate by dividing the rate of discharge (cubic inches per hour) by the area over which it is infiltrating (square inches).
11. Upon completion of the testing, the excavation shall be backfilled

### **Encased Falling Head Test Procedure**

The encased falling head procedure is based on a modification of the EPA Falling Head Percolation Test Procedure (Onsite Wastewater Treatment and Disposal Systems Design Manual, EPA/625/1-80-012, 1980). The most significant modification is that this test is performed with a 6-inch casing that is embedded approximately six inches into the native soil. The goal of this field test is to evaluate the vertical infiltration rate through a 6-inch plug of soil, without allowing any lateral infiltration. The test is not appropriate in gravelly soils or in other soils where a good seal with the casing cannot be established.

1. Embed a solid 6-inch-diameter casing into the native soil at the elevation of the proposed facility bottom (see Figure 7). Ensure that the embedment provides a good seal around the pipe casing so that percolation will be limited to the 6-inch plug of the material within the casing. This method can also be applied to testing within hollow stem augers, provided the driller and tester are reasonably certain that a good seal has been achieved between the soil and auger.
2. A 2-inch layer of coarse sand or fine gravel may be placed to protect the bottom from scour and sloughing.
3. Fill the pipe with clean water a minimum of one foot above the soil to be tested and maintain this depth for at least 4 hours (or overnight if clay soils are present) to presoak the native material.

Percolation rate measurements shall be made after 15 hours and no more than 30 hours after the soaking period begins. It is important that the soil be allowed to soak for a sufficiently long period of time to allow the soil to swell if accurate results are to be obtained. Any soil that sloughed into the hole during the soaking period shall be removed and the water level shall be

adjusted to six inches above the added gravel (or 8 inches above the bottom of the hole).

In sandy soils with little or no clay, soaking is not necessary. If after filling the hole twice with twelve inches of water, the water seeps completely away in less than 10 minutes, the test can proceed immediately.

4. To conduct the first trial of the test, fill the pipe to approximately six inches above the soil and measure the water level to the nearest 0.01-foot (1/8-inch). The level should be measured with a tape or other device with reference to a fixed point. The top of the pipe is often a convenient reference point. Record the exact time.
5. Measure the water level to the nearest 0.01-foot (1/8-inch) at 10-minute intervals for a total period of 1 hour (or 20-minute intervals for 2 hours in slower soils) or until all of the water has drained. The infiltration test is continued until the measured infiltration rate between two successive trials does not vary by more than 5 percent. At least three trials shall be conducted. After each trial, the water level is readjusted to the 6-inch level. Enter results into the Infiltration Test Data Table provided at the end of this section. At no time during the test is the water level allowed to rise more than six inches above the gravel.
6. The result of the last water level drop is used to calculate the tested infiltration rate. The final rate shall be reported in inches per hour.
7. Upon completion of the testing, the casings shall be immediately pulled, and the test pit shall be backfilled.

*Figure 7 Encased Falling Head*

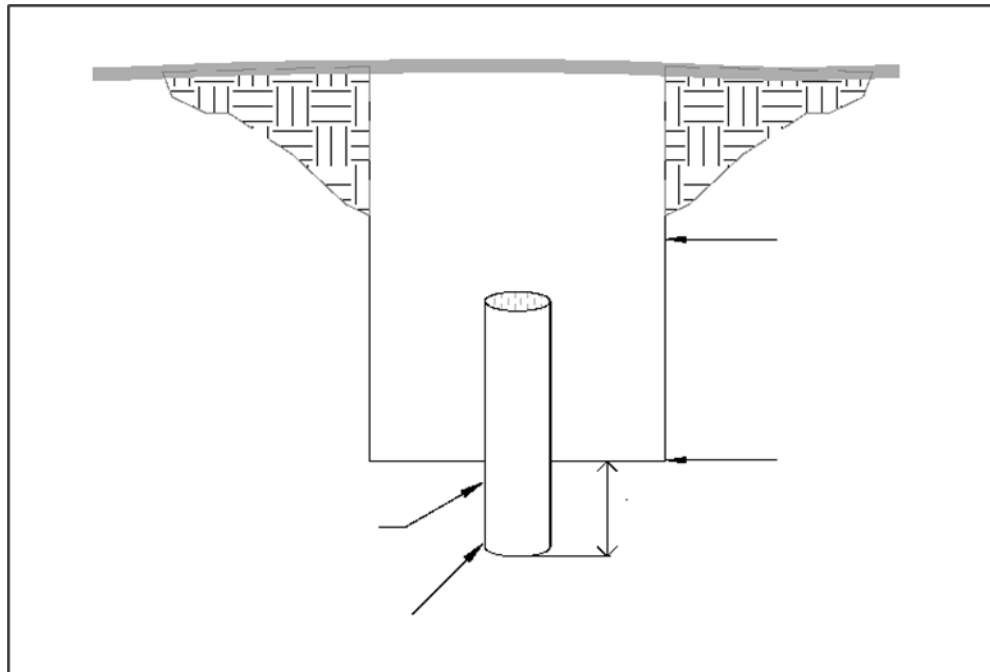

## Double Ring Infiltrometer Test

The double-ring infiltrometer test procedure shall conform with ASTM 3385-94. The test is performed within two concentric casings embedded and sealed to the native soils. The outer ring maintains a volume of water to diminish the potential of lateral infiltration through the center casing. The volume of water added to the center ring to maintain a static water level is used to calculate the infiltration rate. The double-ring infiltrometer is appropriate only in soils where an adequate seal can be established.

This test may be difficult to perform where the tested soil strata are in a pit since careful regulation of the static volumes is necessary.

## Reporting Requirements

In addition to the information required by the state for a signed and stamped Geotechnical Engineering Report, the following information shall be included in the project's submittals.

1. Infiltration results in inches per hour.
2. Location and depth of excavation. The excavation should be deep enough to verify that there is a 5-foot separation between the final depth of the facility (rock gallery) and the seasonal high groundwater or soil layer that could reduce the infiltration rate.
3. Summary and discussion of infiltration testing, including number of tests, amounts of water used in each test (inches, gallons, etc.), and time of each test. Testing is required to show that an accurate rate was achieved.
4. Discussion of how the test was performed:
  - Open pit (size of area)
  - Encased falling head
    - Pipe type and size
    - Embedment depth
  - Double-ring infiltrometer
    - Pipe type and size
    - Embedment depth
5. Table 11 Infiltration Test Data Table provided at the end of this appendix.
6. Soil types with depth.
7. Groundwater observations: seasonal high groundwater level estimation.



Table 11. Infiltration Test Data Table

|                                 |                               |                          |                                  |  |                |
|---------------------------------|-------------------------------|--------------------------|----------------------------------|--|----------------|
| <b>Location:</b>                |                               | <b>Date:</b>             |                                  | <b>Test Hole Number:</b>                 |                |
| <b>Depth to bottom of hole:</b> |                               | <b>Diameter of hole:</b> |                                  | <b>Test Method:</b>                      |                |
| <b>Tester's Name:</b>           |                               |                          |                                  |  |                |
| <b>Tester's Company:</b>        |                               |                          | <b>Tester's Contact Number:</b>  |  |                |
| <b>Depth, feet</b>              |                               |                          | <b>Soil Texture</b>              |  |                |
|                                 |                               |                          |                                  |  |                |
|                                 |                               |                          |                                  |  |                |
|                                 |                               |                          |                                  |  |                |
|                                 |                               |                          |                                  |  |                |
|                                 |                               |                          |                                  |  |                |
| <b>Time</b>                     | <b>Time interval, minutes</b> | <b>Measurement, feet</b> | <b>Drop in water level, feet</b> | <b>Percolation rate, inches per hour</b> | <b>Remarks</b> |
|                                 |                               |                          |                                  |  |                |
|                                 |                               |                          |                                  |  |                |
|                                 |                               |                          |                                  |  |                |
|                                 |                               |                          |                                  |  |                |
|                                 |                               |                          |                                  |  |                |
|                                 |                               |                          |                                  |  |                |
|                                 |                               |                          |                                  |  |                |
|                                 |                               |                          |                                  |  |                |
|                                 |                               |                          |                                  |  |                |

Figure 8. Infiltration Test Data Table Example

| Infiltration Test Data Table Example                |                        |                            |                                   |                                   |                                   |
|---|------------------------|----------------------------|-----------------------------------|-----------------------------------|-----------------------------------|
| Location: Lot 105,<br>Low Point Heights Subdivision |                        | Date: 6/28/2010            |                                   | Test Hole Number: 3               |                                   |
| Depth to bottom of hole: 57 inches                  |                        | Diameter of hole: 0.5 feet |                                   | Test Method: Encased falling head |                                   |
| Tester's Name: C.J. Tester                          |                        |                            | Tester's Contact Number: 555-1212 |                                   |                                   |
| Tester's Company: Tester Company                    |                        |                            |                                   |                                   |                                   |
| Depth, feet   |                        |                            | Soil Texture                      |                                   |                                   |
| 0-0.5   |                        |                            | Black Topsoil                     |                                   |                                   |
| 0.5-1.0   |                        |                            | Brown SM                          |                                   |                                   |
| 1.0-2.2   |                        |                            | Brown ML                          |                                   |                                   |
| 2.2-5.1   |                        |                            | Brown CL                          |                                   |                                   |
| Time  | Time interval, minutes | Measurement, feet          | Drop in water level, feet         | Percolation rate, inches per hour | Remarks                           |
| 9:00  | 0                      | 3.75                       | -                                 |                                   | Filled with 6"                    |
| 9:20  | 20                     | 3.83                       | 0.08                              |                                   |                                   |
| 9:40  | 20                     | 3.91                       | 0.08                              | 2.88                              |                                   |
| 10:00   | 20                     | 3.98                       | 0.07                              | 2.52                              |                                   |
| 10:20   | 20                     | 4.04                       | 0.06                              | 2.16                              |                                   |
| 10:40   | 20                     | 4.11                       | 0.07                              | 2.52                              |                                   |
| 11:00   | 20                     | 4.17                       | 0.06                              | 2.16                              |                                   |
| 11:20   | 20                     | 4.225                      | 0.055                             | 1.98                              |                                   |
|   |                        |                            |                                   |                                   | Adjusted to 6" level for Trial #2 |

## Appendix B STORMWATER FACILITY GUIDANCE

---

### Planting Guide for Vegetated Stormwater Facilities

This appendix provides planting matrices categorized by SMF type. The matrices provide important information on plants approved for installation in each facility type and are intended to guide plant selection for planting plans.

All plants included in these matrices are intended to be drought tolerant but require irrigation temporarily during their establishment period. Even after the establishment period, native plants may require supplemental irrigation during periods of high heat or extended drought. The species listed are representative examples and are not to be considered exclusive or exhaustive for these facility types.

The City of Portland maintains a comprehensive Native Plant List for planting within the Portland metropolitan region that can be found on the City's website.

When a conflict exists between the representative species outlined within this publication and the Native Plant List, the Native Plant List will prevail.

An alternate plant selection may be proposed for review and approval by OLWS. No species included on the Portland Nuisance Plants List will be permitted.

#### Plant Type Information

A description of the type of information provided for each plant table is provided below.

**Plant Name:** Plants are listed by their botanical name first, in italics, followed by a generally accepted common name. Note that common names vary, so use of the botanical name is recommended to ensure proper plant selection

**Zone:** As noted in the zone section of the compiled plant lists, zone denotes the planting moisture zone in which it is appropriate to locate each respective plant. Zone A refers to the highest point on the slope (dry/upland), Zone B refers to the mid-section of the slope (moist/dry) and Zone S refers to the lowest part of the slope (saturated/wet). Refer to the Standard Detail Drawings for zones by facility type. Some plants work in multiple moisture zones, and others only in a particular dry, moist, or wet condition.

**Origin:** Plants approved for stormwater facilities can be grouped into three categories: NW Natives, NW Native Cultivars, and Non-Native Adaptive plants.

**NW Native:** These are plants that are indigenous to the Willamette Valley. They typically require minimal care once they are planted because they have evolved and adapted to the growing conditions and climate of the region. Because of their place in the local ecology, native plants also provide habitat value for birds and other local species. For these reasons, native plants are strongly recommended for stormwater facilities and should be used to the maximum extent practical. In designated vegetated buffers and sensitive areas, only native plants are allowed in SMFs.

**NW Native Cultivar:** These species are cultivated varieties of native plants produced by horticultural techniques and are not normally found in wild populations. Cultivars are

bred for certain desired characteristics that make them different from their native counterparts. Native cultivars may be selected over a native plant if it is more suitable for certain conditions, such as densely urbanized applications. For example, Kelsey dogwood (*Cornus sericea* 'Kelseyi) is a cultivar of the native red twig dogwood (*Cornus sericea*). Kelsey dogwood has been selectively bred to be much smaller at maturity than red twig dogwood, which can be advantageous in small scaled urban stormwater planters. In such instances, the native cultivar is preferred because it will not outgrow the facility or require frequent pruning maintenance, while still offering the same vegetative advantages as its native counterpart.

**Non-Native Adaptive:** These plants are not native to the Willamette Valley but have certain characteristics that make them very useful and well adapted to stormwater facilities. The non-native adapted plants included on the stormwater facility plant lists are considered non-invasive. OLWS prefers that native and native cultivars be used whenever practical but will allow non-native adapted plants where appropriate

**Type/Size:** The following factors provide guidance on individual plant characteristics:

**(E)vergreen/(D)eciduous:** Identifies the characteristic of a plant to keep or lose foliage during winter months. Evergreen plant materials are often preferred at the understory level for stormwater treatment through winter.

**Potential Height:** Identifies maximum size at maturity to use as a design guideline.

**Typical On-Center Spacing:** Identifies the optimum spacing for new plantings. This is to be used as a guideline and may vary slightly depending on site conditions.

### **Context Factors**

The following factors should be considered when selecting vegetation. Consult the appropriate Plant List for guidance.

**Sun/Shade:** When developing planting plans, solar orientation is important to consider. This column identifies which plants are appropriate for full to part sun or shade.

**Facility with underdrain:** In facilities with underdrains, it is important to select plants appropriate for faster draining soils.

**Facility less than 3 feet wide:** Narrow conditions require plants that are not too large and will outgrow or have the potential for roots to be damaged in narrow planters. This column identifies which plants are appropriate for narrow planter widths.

**Lined facility/on top of utilities:** In lined facilities it is important to limit larger material or plants with aggressive and deep roots. This column identifies which plants are appropriate for this application.

**Parking areas:** This column identifies plants that are appropriate for facilities in most parking areas. Large shrubs selected for parking areas should have form and habit that are open and transparent. For portions of parking areas that have line of sight requirements, plants should be selected from the "Streets/Line of Sight" column.

Streets/line of sight: For street-side facilities and in parking areas where line of sight visibility is required, use plant materials that do not limit necessary lines of sight visibility. This column identifies which plants are appropriate for this application.

Adjacent to buildings: When planting adjacent to buildings, limit plant sizes for compatibility with building footings, windows, or other systems. This column identifies which plants are appropriate to use adjacent to buildings.

In Natural Resource Overlay District: If the stormwater facility is within the Natural Resource Overlay District, all plants shall be indigenous to the Willamette Valley.

Public Maintenance: For facilities that will be publicly maintained, plant palette shall be more limited and focused on lower maintenance plants. These facilities should also emphasize more hardy plants that can adapt to higher summer temperatures and extended drought.

Maintenance Legacy: The designer should carefully consider the long-term vegetation management strategy for the stormwater facility, with an emphasis on the anticipated maintenance requirements for the future Owners.

Native vs Blended Soils: Designers should select plants after a careful analysis of the facility's growing medium matrix. Plant material selection should take into account the site-specific characteristics of both blended and underlying native soils, including infiltration rates.

### **Planting Requirements**

While planting sizes, densities, and irrigation requirements are not specified here, vegetation must be installed such that 100 percent vegetative cover is achieved through a mix of herbaceous, groundcover, and shrubs at the end of the warranty period, prior to acceptance. A dense vegetative cover at the ground level must be achieved for maximum water quality treatment.

Planter plant matrices and facility layout figures are provided in the following tables:

- Table 12 – Stormwater Planter Plant List
- Table 13 – Rain Garden Plant List
- Table 14 – Swale Plant List
- Table 15 – Wetland Plant List
- Table 16 – Pond Plant List
- Table 17 – Green Roof Plant List

Table 12. Stormwater Planter Plant List

| Plant Name<br>Botanical Name<br>Common Name         | Zone | Origin    |                    |                    | Type/Size               |                  |                           | Context Factors        |                 |                      |               |         |                       |                |
|---|------|-----------|--------------------|--------------------|-------------------------|------------------|---------------------------|------------------------|-----------------|----------------------|---------------|---------|-----------------------|----------------|
|   |      | NW native | NW native cultivar | non-native adapted | (E)vergreen/(D)eciduous | Potential Height | Typical On Center Spacing | Sun/Shade              | Narrow facility | Fully-lined facility | Parking areas | Streets | Adjacent to buildings | In buffer area |
| <b>Herbaceous Plants</b>                            |      |           |                    |                    |                         |                  |                           |                        |                 |                      |               |         |                       |                |
| <i>Carex densa</i><br>Dense sedge                   | x    | x         |                    |                    | E                       | 24"              | 12"                       | Sun to Part Shade      | x               | x                    | x             | x       | x                     | x              |
| <i>Eleocharis ovata</i><br>Ovate spike rush         | x    | x         |                    |                    | E                       | 30"              | 12"                       | Sun to Part Shade      | x               | x                    | x             | x       | x                     | x              |
| <i>Juncus ensifolius</i><br>Dagger-leaf rush        | x    |           |                    | x                  | D                       | 10"              | 12"                       | Sun to Part Shade      | x               | x                    | x             | x       | x                     |                |
| <i>Juncus patens</i><br>Spreading rush              | x    | x         |                    |                    | E                       | 36"              | 12"                       | Sun, Part Shade, Shade | x               | x                    | x             | x       | x                     | x              |
| <b>Small Shrubs/Groundcover</b>                     |      |           |                    |                    |                         |                  |                           |                        |                 |                      |               |         |                       |                |
| <i>Cornus sericea</i><br>'Kelsey'<br>Kelsey dogwood | x    |           | x                  |                    | D                       | 24"              | 24"                       | Sun to Part Shade      | x               | x                    | x             | x       | x                     |                |
| <i>Mahonia repens</i><br>Creeping Oregon Grape      | x    | x         |                    |                    | E                       | 2'               | 3'                        | Sun, Part Shade, Shade |                 | x                    | x             | x       | x                     | x              |
| <i>Fragaria chiloensis</i><br>Coastal strawberry    | x    | x         |                    |                    | E                       | 6"               | 12"                       | Sun to Part Shade      | x               | x                    | x             | x       | x                     | x              |
| <i>Polystichum munitum</i><br>Sword fern            | x    | x         |                    |                    | E                       | 2'               | 2'                        | Sun, Part Shade, Shade | x               | x                    | x             | x       | x                     | x              |

Table 13. Rain Garden Plant List

| Plant Name<br><br>Botanical Name<br>Common Name     | Zone |   |   | Origin    |                    |                    | Type/Size               |                  |                           | Context Factors     |                 |                     |                      |               |         |                       |
|---|------|---|---|-----------|--------------------|--------------------|-------------------------|------------------|---------------------------|---------------------|-----------------|---------------------|----------------------|---------------|---------|-----------------------|
|   | A    | B | S | NW native | NW native cultivar | non-native adapted | (E)vergreen/(D)eciduous | Potential Height | Typical On Center Spacing | Sun/Shade           | Narrow facility | Publicly maintained | Fully-lined facility | Parking areas | Streets | Adjacent to buildings |
| <b>Herbaceous Plants</b>                            |      |   |   |           |                    |                    |                         |                  |                           |                     |                 |                     |                      |               |         |                       |
| <i>Carex obnupta</i><br>Slough sedge                | X    |   | x | x         |                    |                    | E                       | 48"              | 12"                       | Part to Full Shade  |                 | x                   | x                    | x             | x       | x                     |
| <i>Carex stipata</i><br>Sawbeak sedge               | X    | x | x | x         |                    |                    | D                       | 36"              | 12"                       | Sun to Part Shade   | x               | x                   | x                    | x             | x       | x                     |
| <i>Deschampsia cespitosa</i><br>Tufted hair grass   | X    |   |   | x         |                    |                    | D                       | 36"              | 12"                       | Part Shade          | x               |                     | x                    | x             | x       | x                     |
| <i>Elymus glaucus</i><br>Blue wild rye              | X    | x |   | x         |                    |                    | E                       | 24"              | 12"                       | Part Shade          | x               |                     | x                    | x             | x       | x                     |
| <i>Juncus balticus</i><br>Baltic rush               |      | x | x | x         |                    |                    | E                       | 24"              | 12"                       | Sun                 | x               | x                   | x                    | x             | x       | x                     |
| <i>Juncus patens</i><br>Spreading rush              | X    | x | x |           |                    | x                  | E                       | 36"              | 12"                       | Sun to Part Shade   | x               | x                   | x                    | x             | x       | x                     |
| <i>Scirpus microcarpus</i><br>Small Fruited Bulrush | X    |   | x | x         |                    |                    | E                       | 24"              | 12"                       | Sun                 | x               |                     | x                    | x             | x       | x                     |
| <b>Small Shrubs/Groundcover</b>                     |      |   |   |           |                    |                    |                         |                  |                           |                     |                 |                     |                      |               |         |                       |
| <i>Athyrium filix-femina</i><br>Lady fern           | X    | x |   | x         |                    |                    | E                       | 3'               | 2'                        | Part Shade to Shade | x               |                     | x                    | x             | x       | x                     |
| <i>Arctostaphylos uva-ursi</i><br>Kinnickinnick     | X    | x |   | x         |                    |                    | E                       | 5"               | 3'                        | Sun to Part Shade   | x               | x                   | x                    | x             | x       | x                     |
| <i>Mahonia repens</i><br>Creeping Oregon Grape      | X    | x |   | x         |                    |                    | E                       | 2'               | 3'                        | Part Shade to Shade | x               | x                   | x                    | x             | x       | x                     |
| <i>Philadelphus lewisii</i><br>Mock orange          | X    |   | x | x         |                    |                    | D                       | 6'               | 4'                        | Sun to Part Shade   |                 |                     | x                    | x             | x       | x                     |

| Plant Name<br><br>Botanical Name<br>Common Name  | Zone |   |   | Origin    |                    |                    | Type/Size               |                  |                           | Context Factors        |                 |                     |                      |               |         |                       |
|--|------|---|---|-----------|--------------------|--------------------|-------------------------|------------------|---------------------------|------------------------|-----------------|---------------------|----------------------|---------------|---------|-----------------------|
|  | A    | B | S | NW native | NW native cultivar | non-native adapted | (E)vergreen/(D)eciduous | Potential Height | Typical On Center Spacing | Sun/Shade              | Narrow facility | Publicly maintained | Fully-lined facility | Parking areas | Streets | Adjacent to buildings |
| <i>Polystichum munitum</i><br>Sword fern         | X    | x |   | x         |                    |                    | E                       | 2'               | 2'                        | Part Shade to Shade    | x               |                     | x                    | x             | x       | x                     |
| <i>Symphoricarpos albus</i><br>Snowberry         | X    | x |   | x         |                    |                    | D                       | 3'               | 3'                        | Sun, Part Shade, Shade | x               | x                   | x                    | x             | x       | x                     |
| <b>Large Shrubs/Small Trees</b>                  |      |   |   |           |                    |                    |                         |                  |                           |                        |                 |                     |                      |               |         |                       |
| <i>Cornusericea</i><br>Red twig dogwood          | X    | x | x | x         |                    |                    | D                       | 6'               | 4'                        | Part Shade             |                 |                     |                      |               |         |                       |
| <i>Physocarpus capitatus</i><br>Pacific ninebark | X    |   | x | x         |                    |                    | D                       | 9'               | 3'                        | Sun to Part Shade      |                 |                     | x                    | x             | x       | x                     |
| <i>Rosanutkana</i><br>Nootka rose                | X    | x |   | x         |                    |                    | D                       | 8'               | 4'                        | Sun, Part Shade, Shade |                 |                     | x                    |               | x       |                       |
| <i>Ribes sanguineum</i><br>Red flowering currant | X    | x |   | x         |                    |                    | D                       | 8'               | 4'                        | Sun, Part Shade, Shade |                 | x                   | x                    | x             | x       | x                     |
| <i>Salix sitchensis</i><br>Sitka willow          | X    |   | x | x         |                    |                    | D                       | 15'              | 5'                        | Sun, Part Shade, Shade |                 |                     |                      |               |         |                       |
| <b>Trees*</b>                                    |      |   |   |           |                    |                    |                         |                  |                           |                        |                 |                     |                      |               |         |                       |
| <i>Cornus nuttallii</i><br>Pacific dogwood       | X    | x |   | x         |                    |                    | D                       | 20'              | 10'                       | Sun, Part Shade, Shade | x               |                     | x                    | x             | x       | x                     |
| <i>Rhanmus purshiana</i><br>Cascara              | X    | x |   | x         |                    |                    | D                       | 30'              | 20'                       | Part Sun to Shade      |                 |                     |                      |               |         |                       |
| <i>Calocedrus decurrens</i><br>Incense cedar     | X    | x | x | x         |                    |                    | E                       | 90'              | 15'                       | Part Shade to Shade    |                 |                     |                      | x             |         |                       |

\* Trees are not required but are allowed with adequate soil volume and root space for healthy growth and maturity. Provide minimum two cubic feet of soil volume per square foot of mature canopy size.



Table 14. Swale Plant List

| Plant Name<br><br>Botanical Name<br>Common Name     | Zone |   |   | Origin    |                    |                    | Type/Size               |                  |                           | Context Factors        |                 |                     |                      |               |         |                       |
|---|------|---|---|-----------|--------------------|--------------------|-------------------------|------------------|---------------------------|------------------------|-----------------|---------------------|----------------------|---------------|---------|-----------------------|
|   | A    | B | S | NW native | NW native cultivar | non-native adapted | (E)vergreen/(D)eciduous | Potential Height | Typical On Center Spacing | Sun/Shade              | Narrow facility | Publicly maintained | Fully-lined facility | Parking areas | Streets | Adjacent to buildings |
| <b>Herbaceous Plants</b>                            |      |   |   |           |                    |                    |                         |                  |                           |                        |                 |                     |                      |               |         |                       |
| <i>Carex obnupta</i><br>Slough sedge                | x    |   | x | x         |                    |                    | E                       | 48"              | 12"                       | Part Shade             |                 | x                   | x                    | x             | x       | x                     |
| <i>Carex stipata</i><br>Sawbeak sedge               | x    |   | x | x         |                    |                    | D                       | 36"              | 12"                       | Sun to Part Shade      | x               | x                   | x                    | x             | x       | x                     |
| <i>Deschampsia cespitosa</i><br>Tufted hair grass   | x    |   |   | x         |                    |                    | D                       | 36"              | 12"                       | Part Shade             | x               |                     | x                    | x             | x       | x                     |
| <i>Elymus glaucus</i><br>Blue wild rye              | x    | x |   | x         |                    |                    | E                       | 24"              | 12"                       | Part Shade             | x               |                     | x                    | x             | x       | x                     |
| <i>Juncus balticus</i><br>Baltic rush               |      | x | x | x         |                    |                    | E                       | 24"              | 12"                       | Sun                    | x               |                     | x                    | x             | x       | x                     |
| <i>Juncus patens</i><br>Spreading rush              | x    | x | x |           |                    | x                  | E                       | 36"              | 12"                       | Sun to Part Shade      | x               | x                   | x                    | x             | x       | x                     |
| <i>Scirpus microcarpus</i><br>Small fruited bulrush | x    |   | x | x         |                    |                    | E                       | 24"              | 12"                       | Sun                    | x               | x                   | x                    | x             | x       | x                     |
| <b>Small Shrubs/Groundcover</b>                     |      |   |   |           |                    |                    |                         |                  |                           |                        |                 |                     |                      |               |         |                       |
| <i>Athyrium filix-femina</i><br>Lady fern           | x    | x |   | x         |                    |                    | E                       | 3'               | 2'                        | Sun to Part Shade      | x               |                     | x                    | x             | x       | x                     |
| <i>Arctostaphylos uva-ursi</i><br>Kinnickinnick     | x    | x |   | x         |                    |                    | E                       | 5"               | 3'                        | Sun to Part Shade      | x               |                     | x                    | x             | x       | x                     |
| <i>Fragaria chiloensis</i><br>Coastal strawberry    | x    | x |   | x         |                    |                    | E                       | 6"               | 12"                       | Sun to Part Shade      | x               | x                   | x                    | x             | x       | x                     |
| <i>Mahonia repens</i><br>Creeping Oregon grape      | x    | x |   | x         |                    |                    | E                       | 2'               | 3'                        | Part Shade to Shade    | x               | x                   | x                    | x             | x       | x                     |
| <i>Philadelphus lewisii</i><br>Mock orange          | x    | x |   | x         |                    |                    | D                       | 6'               | 4'                        | Sun to Part Shade      |                 |                     | x                    | x             | x       | x                     |
| <i>Polystichum munitum</i><br>Sword fern            | x    | x |   | x         |                    |                    | E                       | 2'               | 2'                        | Part Shade to Shade    | x               |                     | x                    | x             | x       | x                     |
| <i>Symphoricarpos alba</i><br>Snowberry             | x    | x |   | x         |                    |                    | D                       | 3'               | 3'                        | Sun, Part Shade, Shade | x               | x                   | x                    | x             | x       | x                     |

| Plant Name<br><br>Botanical Name<br>Common Name  | Zone |   |   | Origin    |                    |                    | Type/Size               |                  |                           | Context Factors        |                 |                     |                      |               |         |                       |
|--|------|---|---|-----------|--------------------|--------------------|-------------------------|------------------|---------------------------|------------------------|-----------------|---------------------|----------------------|---------------|---------|-----------------------|
|  | A    | B | S | NW native | NW native cultivar | non-native adapted | (E)vergreen/(D)eciduous | Potential Height | Typical On Center Spacing | Sun/Shade              | Narrow facility | Publicly maintained | Fully-lined facility | Parking areas | Streets | Adjacent to buildings |
| <b>Large Shrubs/Small Trees</b>                  |      |   |   |           |                    |                    |                         |                  |                           |                        |                 |                     |                      |               |         |                       |
| <i>Cornus sericea</i><br>Red twig dogwood        | x    | x | x | x         |                    |                    | D                       | 8'               | 4'                        | Part Shade             |                 |                     |                      |               |         |                       |
| <i>Physocarpus capitatus</i><br>Pacific ninebark | x    |   | x | x         |                    |                    | D                       | 6'               | 3'                        | Sun to Part Shade      |                 |                     | x                    | x             | x       | x                     |
| <i>Rosa nutkana</i><br>Nootka rose               | x    | x |   | x         |                    |                    | D                       | 8'               | 4'                        | Sun, Part Shade, Shade |                 |                     | x                    |               | x       |                       |
| <i>Ribes sanguineum</i><br>Red flowering currant | x    | x |   | x         |                    |                    | D                       | 8'               | 4'                        | Sun, Part Shade, Shade |                 |                     | x                    | x             | x       | x                     |
| <i>Salix sitchensis</i><br>Sitka willow          | x    |   | x | x         |                    |                    | D                       | 15'              | 5'                        | Sun, Part Shade, Shade |                 |                     |                      |               |         |                       |
| <b>Trees*</b>                                    |      |   |   |           |                    |                    |                         |                  |                           |                        |                 |                     |                      |               |         |                       |
| <i>Cornus nuttallii</i><br>Pacific dogwood       | x    | x |   | x         |                    |                    | D                       | 20'              | 10'                       | Sun, Part Shade, Shade | x               |                     | x                    | x             | x       | x                     |
| <i>Rhamnus purshiana</i><br>Cascara              | x    | x |   | x         |                    |                    | D                       | 30'              | 20'                       | Part Shade to Shade    |                 |                     |                      | x             |         |                       |
| <i>Calocedrus decurrens</i><br>Incense cedar     | x    | x | x | x         |                    |                    | E                       | 90'              | 15'                       | Part Shade to Shade    |                 |                     |                      | x             |         |                       |

\*Trees are not required but are allowed with adequate soil volume and root space for healthy growth and maturity. Provide minimum two cubic feet of soil volume per square foot of mature canopy size.

Table 15. Wetland Plant List

| Plant Name<br><br>Botanical Name<br>Common Name     | Zone |   |   | Origin    |                    |                    | Type/Size               |                  |                           | Context Factors        |                 |                      |               |         |                       |
|---|------|---|---|-----------|--------------------|--------------------|-------------------------|------------------|---------------------------|------------------------|-----------------|----------------------|---------------|---------|-----------------------|
|   | A    | B | S | NW native | NW native cultivar | non-native adapted | (E)vergreen/(D)eciduous | Potential Height | Typical On Center Spacing | Sun/Shade              | Narrow facility | Fully-lined facility | Parking areas | Streets | Adjacent to buildings |
| <b>Herbaceous Plants</b>                            |      |   |   |           |                    |                    |                         |                  |                           |                        |                 |                      |               |         |                       |
| <i>Alisma plantago-aquatica</i><br>Water plantain   |      |   | x | x         |                    |                    | D                       | 24"              | 12"                       | Sun                    | x               | x                    |               |         |                       |
| <i>Carex obnupta</i><br>Slough sedge                | x    |   | x | x         |                    |                    | E                       | 48"              | 12"                       | Part Shade             |                 | x                    | x             | x       | x                     |
| <i>Deschampsia cespitosa</i><br>Tufted hair grass   | x    |   |   | x         |                    |                    | D                       | 36"              | 12"                       | Part Shade             | x               | x                    | x             | x       | x                     |
| <i>Elymus glaucus</i><br>Blue wild rye              | x    | x |   | x         |                    |                    | E                       | 24"              | 12"                       | Part Shade             | x               | x                    | x             | x       | x                     |
| <i>Juncus ensifolius</i><br>Dagger-leaf rush        | x    |   | x |           |                    | X                  | D                       | 10"              | 12"                       | Sun to Part Shade      | x               | x                    | x             | x       | x                     |
| <i>Juncus patens</i><br>Spreading rush              | x    | x | x |           |                    | X                  | E                       | 36"              | 12"                       | Sun to Part Shade      | x               | x                    | x             | x       | x                     |
| <i>Scirpus microcarpus</i><br>Small fruited bulrush | x    |   | x | x         |                    |                    | E                       | 24"              | 12"                       | Sun                    | x               | x                    | x             | x       | x                     |
| <b>Small Shrubs/Groundcover</b>                     |      |   |   |           |                    |                    |                         |                  |                           |                        |                 |                      |               |         |                       |
| <i>Mahonia repens</i><br>Creeping Oregon grape      | x    | x |   | x         |                    |                    | E                       | 2'               | 3'                        | Part Shade to Shade    | x               | x                    | x             | x       | x                     |
| <i>Rosa pisocarpa</i><br>Swamp rose                 |      | x | x | x         |                    |                    | D                       | 6'               | 3'                        | Sun to Part Shade      |                 | x                    | x             | x       | x                     |
| <i>Polystichum munitum</i><br>Sword fern            | x    | x |   | x         |                    |                    | E                       | 2'               | 2'                        | Part Shade to Shade    | x               | x                    | x             | x       | x                     |
| <i>Symphoricarpos albus</i><br>Snowberry            | x    | x |   | x         |                    |                    | D                       | 3'               | 3'                        | Sun, Part Shade, Shade | x               | x                    | x             | x       | x                     |
| <b>Large Shrubs/Small Trees</b>                     |      |   |   |           |                    |                    |                         |                  |                           |                        |                 |                      |               |         |                       |
| <i>Cornus sericea</i><br>Red twig dogwood           | x    | x | x | x         |                    |                    | D                       | 8'               | 4'                        | Part Shade             |                 |                      |               |         |                       |

| Plant Name<br><br>Botanical Name<br>Common Name  | Zone |   |   | Origin    |                    |                    | Type/Size               |                  |                           | Context Factors        |                 |                      |               |         |                       |
|--|------|---|---|-----------|--------------------|--------------------|-------------------------|------------------|---------------------------|------------------------|-----------------|----------------------|---------------|---------|-----------------------|
|  | A    | B | S | NW native | NW native cultivar | non-native adapted | (E)vergreen/(D)eciduous | Potential Height | Typical On Center Spacing | Sun/Shade              | Narrow facility | Fully-lined facility | Parking areas | Streets | Adjacent to buildings |
| <i>Physocarpus capitatus</i><br>Pacific ninebark | x    |   | x | x         |                    |                    | D                       | 6'               | 3'                        | Sun to Part Shade      |                 | x                    | x             | x       | x                     |
| <i>Rosa nutkana</i><br>Nootka rose               | x    | x |   | x         |                    |                    | D                       | 8'               | 4'                        | Sun, Part Shade, Shade |                 | x                    |               | x       |                       |
| <i>Ribes sanguineum</i><br>Red flowering currant | x    | x |   | x         |                    |                    | D                       | 8'               | 4'                        | Sun, Part Shade, Shade |                 | x                    | x             | x       | x                     |
| <i>Salix sitchensis</i><br>Sitka willow          | x    |   | x | x         |                    |                    | D                       | 15'              | 5'                        | Sun, Part Shade, Shade |                 |                      |               |         |                       |
| <i>Ceanothus velutinus</i><br>Snowbrush          | x    | x |   | x         |                    |                    | E                       | 6'               | 3'                        | Sun, Part Shade, Shade |                 | x                    | x             | x       | x                     |
| <b>Trees</b>                                     |      |   |   |           |                    |                    |                         |                  |                           |                        |                 |                      |               |         |                       |
| <i>Acer circinatum</i><br>Vine maple             | x    | x |   | x         |                    |                    | D                       | 15'              | 8'                        | Part Shade to Shade    | x               | x                    | x             | x       | x                     |
| <i>Cornus nuttallii</i><br>Pacific dogwood       | x    | x |   | x         |                    |                    | D                       | 20'              | 10'                       | Sun, Part Shade, Shade | x               | x                    | x             | x       | x                     |
| <i>Fraxinus latifolia</i><br>Oregon ash          | x    |   | x | x         |                    |                    | D                       | 30'              | 25'                       | Sun                    |                 |                      |               |         |                       |
| <i>Calocedrus decurrens</i><br>Incense cedar     | x    | x | x | x         |                    |                    | E                       | 90'              | 16'                       | Part Shade to Shade    |                 |                      | x             |         |                       |

Table 16. Pond Plant List

| Plant Name<br>Botanical Name<br>Common Name         | Zone |   |   | Origin    |                    |                    | Type/Size               |                  |                           | Context Factors        |                |                     |                      |               |         |                       |
|---|------|---|---|-----------|--------------------|--------------------|-------------------------|------------------|---------------------------|------------------------|----------------|---------------------|----------------------|---------------|---------|-----------------------|
|   | A    | B | S | NW native | NW native cultivar | non-native adapted | (E)vergreen/(D)eciduous | Potential Height | Typical On Center Spacing | Sun/Shade              | Facility width | Publicly maintained | Fully-lined facility | Parking areas | Streets | Adjacent to buildings |
| <b>Herbaceous Plants</b>                            |      |   |   |           |                    |                    |                         |                  |                           |                        |                |                     |                      |               |         |                       |
| <i>Alisma plantago-aquatica</i><br>Water plantain   | S    |   | x | x         |                    |                    | D                       | 24"              | 12"                       | Sun                    | x              |                     | x                    |               |         |                       |
| <i>Carex obnupta</i><br>Slough sedge                | x    |   | x | x         |                    |                    | E                       | 48"              | 12"                       | Part Shade             |                | x                   | x                    | x             | x       | x                     |
| <i>Deschampsia cespitosa</i><br>Tufted hair grass   | x    |   |   | x         |                    |                    | D                       | 36"              | 12"                       | Part Shade             | x              | x                   | x                    | x             | x       | x                     |
| <i>Elymus glaucus</i><br>Blue wild rye              | x    | x |   | x         |                    |                    | E                       | 24"              | 12"                       | Part Shade             | x              |                     | x                    | x             | x       | x                     |
| <i>Juncus ensifolius</i><br>Dagger-leaf rush        | x    |   | x |           |                    | x                  | D                       | 10"              | 12"                       | Sun to Part Shade      | x              | x                   | x                    | x             | x       | x                     |
| <i>Juncus patens</i><br>Spreading rush              | x    | x | x |           |                    | x                  | E                       | 36"              | 12"                       | Sun to Part Shade      | x              | x                   | x                    | x             | x       | x                     |
| <i>Scirpus microcarpus</i><br>Small fruited bulrush | x    |   | x | x         |                    |                    | E                       | 24"              | 12"                       | Sun                    | x              | x                   | x                    | x             | x       | x                     |
| <b>Small Shrubs/Groundcover</b>                     |      |   |   |           |                    |                    |                         |                  |                           |                        |                |                     |                      |               |         |                       |
| <i>Athyrium filix-femina</i><br>Lady fern           | x    | x |   | x         |                    |                    | E                       | 3'               | 2'                        | Part Shade to Shade    | x              |                     | x                    | x             | x       | x                     |
| <i>Mahonia repens</i><br>Creeping Oregon grape      | x    | x |   | x         |                    |                    | E                       | 2'               | 3'                        | Part Shade to Shade    | x              |                     | x                    | x             | x       | x                     |
| <i>Polystichum munitum</i><br>Sword fern            | x    | x |   | x         |                    |                    | E                       | 2'               | 2'                        | Part Shade to Shade    | x              |                     | x                    | x             | x       | x                     |
| <i>Symphoricarpos albus</i><br>Snowberry            | x    | x |   | x         |                    |                    | D                       | 3'               | 3'                        | Sun, Part Shade, Shade | x              | x                   | x                    | x             | x       | x                     |
| <b>Large Shrubs/Small Trees</b>                     |      |   |   |           |                    |                    |                         |                  |                           |                        |                |                     |                      |               |         |                       |

| Plant Name                                       | Zone |   |   | Origin    |                    |                    | Type/Size               |                  |                           | Context Factors        |                |                     |                      |               |         |                       |
|--|------|---|---|-----------|--------------------|--------------------|-------------------------|------------------|---------------------------|------------------------|----------------|---------------------|----------------------|---------------|---------|-----------------------|
|  | A    | B | S | NW native | NW native cultivar | non-native adapted | (E)vergreen/(D)eciduous | Potential Height | Typical On Center Spacing | Sun/Shade              | Facility width | Publicly maintained | Fully-lined facility | Parking areas | Streets | Adjacent to buildings |
| <i>Cornus sericea</i><br>Red twig dogwood        | x    | x | x | x         |                    |                    | D                       | 8'               | 4'                        | Part Shade             |                | x                   |                      |               |         |                       |
| <i>Physocarpus capitatus</i><br>Pacific ninebark | x    |   | x | x         |                    |                    | D                       | 6'               | 3'                        | Sun to Part Shade      |                | x                   | x                    | x             | x       | x                     |
| <i>Philadelphus lewisii</i><br>Mock Orange       | x    | x |   | x         |                    |                    | D                       | 6'               | 4'                        | Sun to Part Shade      |                | x                   | x                    | x             | x       | x                     |
| <i>Rosa Nutkana</i><br>Nootka rose               | x    | x |   | x         |                    |                    | D                       | 8'               | 4'                        | Sun, Part Shade, Shade |                |                     | x                    |               | x       |                       |
| <i>Ribes sanguineum</i><br>Red flowering currant | x    | x |   | x         |                    |                    | D                       | 8'               | 4'                        | Sun, Part Shade, Shade |                | x                   | x                    | x             | x       | x                     |
| <i>Salix sitchensis</i><br>Sitka willow          | x    |   | x | x         |                    |                    | D                       | 15'              | 5'                        | Sun, Part Shade, Shade |                |                     |                      |               |         |                       |
| <i>Ceanothus velutinus</i><br>Snowbrush          | x    | x |   | x         |                    |                    | E                       | 6'               | 3'                        | Sun, Part Shade, Shade |                | x                   | x                    | x             | x       | x                     |
| <b>Trees</b>                                     |      |   |   |           |                    |                    |                         |                  |                           |                        |                |                     |                      |               |         |                       |
| <i>Acer circinatum</i><br>Vine maple             | x    | x |   | x         |                    |                    | D                       | 15'              | 8'                        | Part Shade to Shade    | x              |                     | x                    | x             | x       | x                     |
| <i>Cornus nuttallii</i><br>Pacific dogwood       | x    | x |   | x         |                    |                    | D                       | 20'              | 10'                       | Sun, Part Shade, Shade | x              |                     | x                    | x             | x       | x                     |
| <i>Rhamnus purshiana</i><br>Cascara              | x    | x |   | x         |                    |                    | D                       | 30'              | 20'                       | Part Sun to Shade      |                |                     |                      |               |         |                       |
| <i>Calocedrus</i><br>Incense cedar               | x    | x | x | x         |                    |                    | E                       | 90'              | 15'                       | Part Shade to Shade    |                |                     |                      | x             |         |                       |

Table 17. Green Roof Plant List

| Plant Name<br><br>Botanical Name<br>Common Name               | Zone |   | Origin    |                    |                    | Type/Size                   |                  |                           | Context                |
|---|------|---|-----------|--------------------|--------------------|-----------------------------|------------------|---------------------------|------------------------|
|   | C    | D | NW native | NW native cultivar | non-native adapted | (E)vergreen/<br>(D)eciduous | Potential Height | Typical On Center Spacing | Sun/Shade              |
| <b>Sedums and Succulents</b>                                  |      |   |           |                    |                    |                             |                  |                           |                        |
| <i>Delosperma</i> ssp.<br>Ice plant                           | x    | x |           |                    | x                  | E                           | 4"               | 6"-12"                    | Sun                    |
| <i>Malephora crocea</i> v.<br><i>purpurea</i> Coppery mesemb  | x    | x |           |                    | x                  | E                           | 10"              | 6"-12"                    | Sun to Part Shade      |
| <i>Sedum album</i><br>White stonecrop                         | x    |   |           |                    | x                  | E                           | 3"               | 6"-12"                    | Sun                    |
| <i>Sedum oreganum</i><br>Oregon stonecrop                     | x    | x | x         |                    |                    | E                           | 4"               | 6"-12"                    | Sun to Part Shade      |
| <i>Sedum spathulifolium</i><br>Stonecrop                      | x    | x |           |                    | x                  | E                           | 4"               | 6"-12"                    | Sun to Part Shade      |
| <i>Sedum spurium</i><br>Two-row stonecrop                     | x    | x |           |                    | x                  | E                           | 6"               | 6"-12"                    | Sun                    |
| <i>Sempervivum tectorum</i><br>Hens and chicks                | x    |   |           |                    | x                  | E                           | 3"               | 6"-12"                    | Sun to Part Shade      |
| <b>Herbaceous Plants</b>                                      |      |   |           |                    |                    |                             |                  |                           |                        |
| <i>Achillea millefolium</i><br>Common yarrow                  | x    | x |           |                    | x                  | D                           | 24"              | 24"                       | Sun to Part Shade      |
| <i>Artemisia</i> 'Silver Mound'<br>Silver mound artemisia     | x    | x |           |                    | x                  | D                           | 12"              | 12"                       | Sun to Part Shade      |
| <i>Castilleja foliolosa</i><br>Woolly Indian paintbrush       | x    | x | x         |                    |                    | D                           | 10"              | 12"                       | Sun                    |
| <i>Festuca glauca</i> 'Elijah's Blue'<br>Elijah's blue fescue | x    | x |           |                    | x                  | E                           | 12"              | 12"                       | Sun                    |
| <i>Fragaria chiloensis</i><br>Coastal strawberry              | x    | x | x         |                    |                    | E                           | 6"               | 12"                       | Sun to Part Shade      |
| <i>Polystichum munitum</i><br>Sword fern                      | x    | x | x         |                    |                    | E                           | 24"              | 24"                       | Sun, Part Shade, Shade |
| <i>Thymus serpyllum</i><br>Creeping thyme                     | x    |   |           |                    | x                  | D                           | 3"               | 6"                        | Sun, Part Shade, Shade |

## **Stormwater Facility Operations and Maintenance Guidance**

Stormwater Planter

Rain Garden

Vegetated Swale

Filter Strip

Drywell

Infiltration Trench

Detention Pond

Constructed Wetlands

Structural Detention

Pervious Pavement

Green Roof

Stormwater Facility inspection and Maintenance Log



## Stormwater Planters

***NO** pesticide, herbicide, or fungicide use is allowed.*

Clean up spills immediately. Remove and replace contaminated soil. Call Metro to determine proper disposal requirements of spill response materials and contaminated soil. Record the date and spill response measures in the inspection log.

| Structural Component  | Spring | Summer | Fall | Winter | 24-hr<br>Precip > 1" |
|---|--------|--------|------|--------|----------------------|
| Replace or repair inlets if they are cracked or broken. Reseal inlet pipes if they are not watertight.                        | X      |        | X    |        |                      |
| Check overflow caps and replace if cracked or missing.  | X      |        | X    |        | X                    |
| Check flow spreader, if present, and repair as necessary. Check inlet protection and replace or replenish rock, as necessary. | X      |        | X    |        |                      |
| Check liner, if present, and repair tears or holes, as necessary. Replace liner, as necessary.                                | X      |        | X    |        |                      |
| Patch concrete.   |        | X      | X    |        |                      |

| Ponding Area  | Spring | Summer | Fall | Winter | 24-hr<br>Precip > 1" |
|---|--------|--------|------|--------|----------------------|
| Remove trash.   | X      | X      | X    | X      | X                    |
| Remove sediment from ponding area, forebays, and inlets.  | X      |        | X    |        | X                    |
| Repair any erosion around edges of concrete forebay if erosion is occurring.  |        | X      | X    |        | X                    |
| Check trench drains discharging to the facility and remove any soil or debris.  | X      | X      | X    | X      | X                    |
| Check for channeled flow in facility; fill in channels with soil and add plants to disperse flow.   |        | X      | X    |        | X                    |
| Add three inches of mulch or topsoil to bare areas and reseed or replant to achieve 100% coverage at maturity. Do not add bark dust or bark chips; they will float and then clog the outlet or create bare spots. | X      |        |      |        |                      |
| Remove weeds, invasive plants, and dead plants. Replant or reseed to achieve 100% coverage at maturity  | X      | X      | X    |        |                      |
| Thin grasses (remove dead blades) or remove top third of previous year's growth.  | X      |        |      |        |                      |
| Prune shrubs.   | X      |        |      | X      |                      |
| If facility drains slowly, rake soil to stop crusting. Replace or amend soil if ponding occurs more than 24 hours   | X      |        | X    | X      | X                    |
| Ponding should not occur for more than 48 hours.  | X      |        | X    | X      | X                    |

## Rain Gardens

***NO** pesticide, herbicide, or fungicide use is allowed.*

Clean up spills immediately. Remove and replace contaminated soil. Call Metro to determine proper disposal requirements of spill response materials and contaminated soil. Record the date and spill response measures in the inspection log.

| Structural Repairs  | Spring | Summer | Fall | Winter | 24-hr Precip<br>> 1" |
|---|--------|--------|------|--------|----------------------|
| Replace or repair inlets if they are cracked or broken.<br>Reseal inlet pipes if they are not watertight.                         | X      |        | X    |        |                      |
| Check overflow caps and replace if cracked or missing.  | X      |        | X    |        | X                    |
| Check flow spreader, if present, and repair, as necessary.<br>Check inlet protection and replace or replenish rock, as necessary. | X      |        | X    |        |                      |

| Ponding Area  | Spring | Summer | Fall | Winter | 24-hr Precip<br>> 1" |
|---|--------|--------|------|--------|----------------------|
| Remove trash.   | X      | X      | X    | X      | X                    |
| Remove sediment from ponding area, forebays, and inlets.  | X      |        | X    |        | X                    |
| Repair any erosion around edges of concrete forebay if erosion is occurring.  |        | X      | X    |        | X                    |
| Check trench drains discharging to the facility and remove any soil or debris.  | X      | X      | X    | X      | X                    |
| Check for channeled flow in facility; fill in channels with soil and add plants to disperse flow.   |        | X      | X    |        | X                    |
| Add three inches of mulch or topsoil to bare areas and reseed or replant to achieve 100% coverage at maturity. Do not add bark dust or bark chips; they will float and then clog the outlet or create bare spots. | X      |        |      |        |                      |
| Remove weeds, invasive plants, and dead plants. Replant or reseed to achieve 100% coverage at maturity  | X      | X      | X    |        |                      |
| Thin grasses (remove dead blades) or remove top third of previous year's growth.  | X      |        |      |        |                      |
| Prune shrubs and trees.   | X      |        |      | X      |                      |
| If facility drains slowly, rake soil to stop crusting. Replace or amend soil if ponding occurs more than 24 hours.  | X      |        | X    | X      | X                    |
| Ponding should not occur for more than 48 hours.  | X      |        | X    | X      | X                    |

## Vegetated Swales

***NO** pesticide, herbicide, or fungicide use is allowed.*

Clean up spills immediately. Remove and replace contaminated soil. Call Metro to determine proper disposal requirements of spill response materials and contaminated soil. Record the date and spill response measures in the inspection log.

| Structural Repairs   | Spring | Summer | Fall | Winter | 24-hr Precip<br>> 1" |
|--|--------|--------|------|--------|----------------------|
| Replace or repair inlets if they are cracked or broken. Reseal inlet pipes if they are not watertight.                         | X      |        | X    |        |                      |
| Check overflow caps or grates and repair, as necessary. Replace if they are missing.   | X      |        | X    |        | X                    |
| Check flow spreader, if present, and repair, as necessary. Check inlet protection and replace or replenish rock, as necessary. | X      |        | X    |        |                      |

| Ponding Area  | Spring | Summer | Fall | Winter | 24-hr Precip<br>> 1" |
|---|--------|--------|------|--------|----------------------|
| Remove trash.   | X      | X      | X    | X      | X                    |
| Remove sediment from ponding area, forebays, and inlets.  | X      |        | X    |        | X                    |
| Repair any erosion around edges of concrete forebay if erosion is occurring.  |        | X      | X    |        | X                    |
| Check trench drains discharging to the facility and remove any soil or debris.  | X      | X      | X    | X      | X                    |
| Check for channeled flow in facility; fill in channels with soil and add plants to disperse flow.   |        | X      | X    |        | X                    |
| Add three inches of mulch or topsoil to bare areas and reseed or replant to achieve 100% coverage at maturity. Do not add bark dust or bark chips; they will float and then clog the outlet or create bare spots. | X      |        |      |        |                      |
| Remove weeds, invasive plants, and dead plants. Replant or reseed to achieve 100% coverage at maturity  | X      | X      | X    |        |                      |
| Thin grasses (remove dead blades) or remove top third of previous year's growth.  | X      |        |      |        |                      |
| Prune shrubs and trees.   | X      |        |      | X      |                      |
| If facility drains slowly, rake soil to stop crusting. Replace or amend soil if ponding occurs more than 24 hours.  | X      |        | X    | X      | X                    |
| Ponding should not occur for more than 48 hours.  | X      |        | X    | X      | X                    |

## Filter Strips or Landscaped Areas Receiving Sheetflow from Impervious Areas

*NO pesticide, herbicide, or fungicide use is allowed.*

Clean up spills immediately. Remove and replace contaminated soil. Call Metro to determine proper disposal requirements of spill response materials and contaminated soil. Record the date and spill response measures in the inspection log.

| Maintenance Component  | Spring | Summer | Fall | Winter | 24-hr<br>Precip > 1" |
|--|--------|--------|------|--------|----------------------|
| Remove trash.  | X      | X      | X    | X      | X                    |
| Remove accumulated sediment.   | X      |        | X    |        | X                    |
| Replace or replenish rock bordering filter strip or sheet flow area, as necessary.   |        | X      | X    |        | X                    |
| Check flow spreader, if present, and repair, as necessary. Check inlet protection and replace or replenish rock, as necessary.       | X      |        |      | X      | X                    |
| Check trench drains leading to the facility and remove any soil or debris.   | X      | X      | X    | X      | X                    |
| Check for channeled flow; fill in channels with soil and add plants to disperse flow.  | X      |        | X    |        | X                    |
| Remove weeds, invasive plants, and dead plants. Replant or reseed to achieve 100% coverage at maturity                               | X      | X      | X    |        |                      |
| Thin grasses (remove dead blades) or remove top third of previous year's growth.   | X      |        |      |        |                      |
| Prune shrubs and trees.  | X      |        |      | X      |                      |
| If moss is present, aerate the area or add 1/2-inch of 3/4-inch clean (no fines) rock.   | X      |        | X    |        |                      |
| If facility drains slowly, aerate grasses or rake soil to stop crusting. Replace or amend soil if ponding occurs more than 24 hours. | X      |        | X    | X      | X                    |
| Ponding should not occur for more than 48 hours.   | X      |        | X    | X      | X                    |

## Dry Wells

***NO** pesticide, herbicide, or fungicide use is allowed.*

Clean up spills immediately. Have drywell professionally cleaned and notify DEQ. Record the date and spill response measures in the inspection log.

| Maintenance Component   | Spring | Summer | Fall | Winter | 24-hr<br>Precip > 1" |
|---|--------|--------|------|--------|----------------------|
| Replace or repair inlets if they are cracked or broken. Reseal inlet pipes if they are not watertight.  |        | X      | X    |        |                      |
| Remove sediment from catch basin.   | X      |        | X    |        | X                    |
| Remove leaf litter/debris from gutters.   | X      |        | X    |        |                      |
| Check trench drains leading to the facility and remove any soil or debris.  | X      | X      | X    | X      | X                    |
| Remove inspection portal lid and check for spalling or cracking of walls and for root intrusions. Repair, as necessary.                       |        | X      | X    |        |                      |
| Remove inspection portal lid and check sediment depth. Have professionally cleaned when depth of sediment or debris is six inches or greater. |        | X      | X    |        |                      |
| Ponding should not occur for more than 48 hours.  | X      |        | X    | X      | X                    |

## Infiltration Trenches

***NO** pesticide, herbicide, or fungicide use is allowed.*

Clean up spills immediately. Have drywell professionally cleaned and notify DEQ. Record the date and spill response measures in the inspection log.

| Maintenance Component   | Spring | Summer | Fall | Winter | 24-hr<br>Precip > 1" |
|---|--------|--------|------|--------|----------------------|
| Replace or repair inlets if they are cracked or broken. Reseal inlet pipes if they are not watertight.  |        | X      | X    |        |                      |
| Remove sediment from catch basin.   | X      |        | X    |        | X                    |
| Remove leaf litter/debris from gutters.   | X      |        | X    |        |                      |
| Check trench drains leading to the facility and remove any soil or debris.  | X      | X      | X    | X      | X                    |
| Remove inspection portal lid. Check for cracking of walls and root intrusion. Remove roots and repair walls, as necessary. Have professionally cleaned when depth of sediment or debris is three inches or greater. |        | X      | X    |        | X                    |
| Ponding should not occur for more than 48 hours.  | X      |        | X    | X      | X                    |

## Detention Pond

*NO pesticide, herbicide, or fungicide use is allowed.*

Clean up spills immediately. Remove and replace contaminated soil. Call Metro to determine proper disposal requirements of spill response materials and contaminated soil. Record the date and spill response measures in the inspection log.

| Structural Repairs   | Spring | Summer | Fall | Winter | 24-hr Precip<br>> 1" |
|--|--------|--------|------|--------|----------------------|
| Replace or repair inlets if they are cracked or broken. Reseal inlet pipes if they are not watertight.                                 | X      |        | X    |        |                      |
| Remove sediment in catch basins discharging to pond.   | X      |        | X    |        |                      |
| Inspect outlet structure. Clean clogged orifices. Repair cracked or broken shear gate and handles.                                     |        | X      | X    |        |                      |
| Check spillway and berms. Add erosion control matting to areas of slight or moderate erosion.  |        | X      | X    |        | X                    |
| Check spillway and berms. Contact OLWS at 503.742.4567 if the erosion is severe or there is evidence of concrete cracking or spalling. |        | X      | X    |        | X                    |

| Ponding Area   | Spring | Summer | Fall | Winter | 24-hr Precip<br>> 1" |
|--|--------|--------|------|--------|----------------------|
| Remove trash.  | X      | X      | X    | X      | X                    |
| Remove sediment from ponding area and inlets.  |        | X      | X    |        | X                    |
| Replace or replenish rock at inlets if erosion is occurring.   |        | X      | X    |        | X                    |
| Check flow dissipaters. Repair or replace diffuser, as necessary. Replace or replenish rock, as necessary.   |        | X      | X    |        |                      |
| Add three inches of mulch or topsoil to bare areas and reseed or replant to achieve 100% coverage. Do not add bark dust or bark chips; they will float as the wetland refills and either clog the outlet or create bare spots in the ponding area. | X      | X      | X    |        |                      |
| Remove weeds, invasive plants, and dead plants. Replant or reseed to achieve 100% coverage at maturity   | X      | X      | X    |        |                      |
| Thin grasses (remove dead blades) or remove top third of previous year's growth if desired.  | X      |        |      |        |                      |
| Prune shrubs and trees.  | X      |        |      | X      |                      |
| Check depth or high-water mark in several areas. If depth is less than 50% of design depth, dredge area and replant. If depth is more than 150% of the design depth, add soil and replant in channeled area.                                       | X      |        | X    |        |                      |

## Constructed Wetlands

*NO pesticide, herbicide, or fungicide use is allowed.*

Clean up spills immediately. Remove and replace contaminated soil. Call Metro to determine proper disposal requirements of spill response materials and contaminated soil. Record the date and spill response measures in the inspection log.

| Structural Repairs   | Spring | Summer | Fall | Winter | 24-hr Precip<br>> 1" |
|--|--------|--------|------|--------|----------------------|
| Replace or repair inlets if they are cracked or broken. Reseal inlet pipes if they are not watertight.                                 | X      |        | X    |        |                      |
| Remove sediment in catch basins discharging to wetlands.   | X      |        | X    |        |                      |
| Inspect outlet structure. Clean clogged orifices. Repair cracked or broken shear gate and handles.                                     |        | X      | X    |        |                      |
| Check spillway and berms. Add erosion control matting to areas of slight or moderate erosion.  |        | X      | X    |        | X                    |
| Check spillway and berms. Contact OLWS at 503.742.4567 if the erosion is severe or there is evidence of concrete cracking or spalling. |        | X      | X    |        | X                    |

| Ponding Area   | Spring | Summer | Fall | Winter | 24-hr Precip<br>> 1" |
|--|--------|--------|------|--------|----------------------|
| Remove trash.  | X      | X      | X    | X      | X                    |
| Remove sediment from ponding area and inlets.  |        | X      | X    |        | X                    |
| Replace or replenish rock at inlets if erosion is occurring.   |        | X      | X    |        | X                    |
| Check flow dissipaters. Repair or replace diffuser, as necessary. Replace or replenish rock, as necessary.   |        | X      | X    |        |                      |
| Add three inches of mulch or topsoil to bare areas and reseed or replant to achieve 100% coverage. Do not add bark dust or bark chips; they will float as the wetland refills and either clog the outlet or create bare spots in the ponding area. | X      | X      | X    |        |                      |
| Remove weeds, invasive plants, and dead plants. Replant or reseed to achieve 100% coverage at maturity   | X      | X      | X    |        |                      |
| Thin grasses (remove dead blades) or remove top third of previous year's growth if desired.  | X      |        |      |        |                      |
| Prune shrubs and trees.  | X      |        |      | X      |                      |
| Check depth or high-water mark in several areas. If depth is less than 50% of design depth, dredge area and replant. If depth is more than 150% of the design depth, add soil and replant in channeled area.                                       | X      |        | X    |        |                      |



## Structural Detention

***NO** pesticide, herbicide, or fungicide use is allowed.*

Clean up spills immediately. Call Metro to determine proper disposal requirements of spill response materials. Record the date and spill response measures in the inspection log.

| Structural Component   | Spring | Summer | Fall | Winter | 24-hr<br>Precip > 1" |
|--|--------|--------|------|--------|----------------------|
| Replace or repair inlets if they are cracked or broken. Reseal inlet pipes if they are not watertight.   | X      |        | X    |        |                      |
| Remove sediment in catch basins discharging to tank or vault.  | X      |        | X    |        | X                    |
| Remove inspection portal lid, check for root intrusion, and remove roots and repair facility, as necessary. Check sediment depth and have professionally cleaned when depth of sediment and debris is > 15 percent of diameter at any point or > 6 inches below pipe invert. |        | X      | X    |        | X                    |

## Pavers and Pervious Pavement

***NO** pesticide, herbicide, fungicide, or moss inhibitor use is allowed.*

*NO sand or deicer should be used on paver area.*

Clean up spills immediately. Call Metro to determine proper disposal requirements of spill response materials. Record the date and spill response measures in the inspection log.

| Maintenance Component   | Spring | Summer | Fall | Winter | 24-hr<br>Precip > 1" |
|---|--------|--------|------|--------|----------------------|
| Check for moss growth. Use baking soda to kill moss and then scrape dead moss off and throw in yard waste bin.  | X      |        |      | X      |                      |
| Sweep leaf litter and debris off pavement. Use a professional pavement sweeper or wet/dry vacuum, as necessary.<br><b>NO</b> pressure washing; it clogs the pavement. | X      |        | X    |        | X                    |
| Remove overhanging plants or grass near pavers.   |        | X      | X    |        |                      |
| During rainstorms, check for water running onto surface and divert water away from pavement.  |        |        | X    | X      | X                    |
| Repair cracks and settling, as necessary.   | X      | X      |      |        |                      |
| No ponding or runoff should occur on the pavement.  | X      |        | X    | X      | X                    |

## Green Roofs

*NO pesticide, herbicide, or fungicide use is allowed.*

Clean up spills immediately. Call Metro to determine proper disposal requirements of spill response materials. Record the date and spill response measures in the inspection log.

Maintain system per manufacturer's requirements.

|  |  |
|--|--|
| <b>Stormwater Facilities Inspection and Maintenance Log</b>                        |  |
| <b>OWNER:</b>  | <b>CONTACT INFO:</b>   |
| <b>FACILITY LOCATION/ADDRESS:</b><br><b>FACILITY TYPE:</b><br><b>ACCESS NOTES:</b> |  |

*Refer to the facility's quarterly inspection requirements in the O&M Plan before conducting inspections and maintenance actions.*

**INSPECTION YEAR:**

| <b>WINTER INSPECTION LOG</b>           | <b>SPRING INSPECTION LOG</b>           | <b>SUMMER INSPECTION LOG</b>           | <b>FALL INSPECTION LOG</b>             |
|--|--|--|--|
| <b>DATE:</b>                           | <b>DATE:</b>                           | <b>DATE:</b>                           | <b>DATE:</b>                           |
| <b>INSPECTOR NAME:</b>                 | <b>INSPECTOR NAME:</b>                 | <b>INSPECTOR NAME:</b>                 | <b>INSPECTOR NAME:</b>                 |
| <b>COMPONENTS INSPECTED*:</b>          | <b>COMPONENTS INSPECTED*:</b>          | <b>COMPONENTS INSPECTED*:</b>          | <b>COMPONENTS INSPECTED*:</b>          |
| STRUCTURAL: <input type="checkbox"/>   | STRUCTURAL: <input type="checkbox"/>   | STRUCTURAL: <input type="checkbox"/>   | STRUCTURAL: <input type="checkbox"/>   |
| PONDING AREA: <input type="checkbox"/> | PONDING AREA: <input type="checkbox"/> | PONDING AREA: <input type="checkbox"/> | PONDING AREA: <input type="checkbox"/> |
| VEGETATION: <input type="checkbox"/>   | VEGETATION: <input type="checkbox"/>   | VEGETATION: <input type="checkbox"/>   | VEGETATION: <input type="checkbox"/>   |
| <b>MAINTENANCE ACTIONS PERFORMED:</b>  | <b>MAINTENANCE ACTIONS PERFORMED:</b>  | <b>MAINTENANCE ACTIONS PERFORMED:</b>  | <b>MAINTENANCE ACTIONS PERFORMED:</b>  |

\* **Structural Components** include all 'hard' elements of the facility (inlets, flow spreaders, liners, overflow caps, etc.).

**Ponding Area** includes areas on the surface or underground where stormwater accumulates. Inspect for blockages, sediment, and trash.

**Vegetation** includes maintaining vegetation, so the facility can function as designed (i.e., tree pruning, weed removal, mowing, grass management).

## Appendix C STORMWATER TYPICAL DRAWINGS AND STANDARD DETAILS

---

See Section 5 for OLWS Drawings.

See current Water Environmental Services Stormwater Standards for CC approved drawings:

| <b>Dwg #</b> | <b>Drawing Description</b>    |
|--------------|-------------------------------|
| SWM-14       | CB CURB AND GUTTER DETAIL     |
| SWM-15       | CB CURB INLET                 |
| SWM-16       | CB DITCH INLET                |
| SWM-17       | CB FRAME AND GRATE            |
| SWM-18       | CB STANDARD GB2               |
| SWM-19       | DETENTION TANK DIAGRAM        |
| SWM-20       | POND DIAGRAM                  |
| SWM-21       | SHEAR GATE AND ORIFICE        |
| SWM-22       | FLOW STRUCTURE TYPE 1         |
| SWM-23       | FLOW STRUCTURE TYPE 2         |
| SWM-24       | FLOW STRUCTURE TYPE 3         |
| SWM-25       | MANHOLE BASE                  |
| SWM-26       | MH CHANNEL AND RING EXTENSION |
| SWM-27       | MH DRYWELL                    |
| SWM-28       | MH ENERGY DISSIPATOR          |
| SWM-29       | MH FLEXIBLE CONNECTION        |
| SWM-30       | MH FLOW CONTROL               |
| SWM-31       | MH OVAL GRATE DETAIL          |
| SWM-32       | MH SHALLOW PRECAST            |
| SWM-33       | MH STANDARD                   |
| SWM-34       | MH STEP                       |
| SWM-35       | MH STANDARD FRAME & COVER     |
| SWM-36       | MH SUBURBAN FRAME & COVER     |
| SWM-37       | ANCHOR WALL                   |
| SWM-38       | TRENCH RESTORATION            |
| SWM-39       | TRENCH RESTORATION WITH CDF   |
| SWM-40       | COLLECTION SYSTEM DIAGRAM     |
| SWM-41       | MH LOCATION DIAGRAM           |
| SWM-42       | CURB CUT OPENING              |
| SWM-43       | CURB STAMP DETAIL             |
| SWM-44       | INSERTA TEE                   |
| SWM-45       | OUTFALL RIP RAP               |
| SWM-46       | OUTFALL RIP RAP SIZING        |
| SWM-47       | REMOVABLE BOLLARD             |
| SWM-48       | ROOF DOWNSPOUT SYSTEM         |
| SWM-49       | SERVICE CONNECTION            |

## Appendix D FACILITY SIZING METHODOLOGY AND RESOURCES

---

### Santa Barbara Urban Hydrograph Method

The Santa Barbara Urban Hydrograph (SBUH) method is a single-event model that estimates a flow hydrograph for a representative rainfall event. The SBUH method was developed by the Santa Barbara County Flood Control and Water Conservation District. Applicable to urban areas, it converts design storm incremental rainfall depths into instantaneous unit hydrographs.

#### Elements of the SBUH Method

The SBUH method depends on several variables:

- Pervious ( $A_p$ ) and impervious ( $A_{imp}$ ) land areas
- Time of concentration ( $T_c$ ) calculations
- Runoff curve numbers (CN) applicable to the site
- Design storms

Assumptions for these variables must be explained and justified in the design report.

#### Land Area

The total area, including the pervious and impervious areas within a drainage basin, shall be quantified in order to evaluate critical contributing areas and the resulting site runoff. Each area with a basin shall be analyzed separately and their hydrographs combined to determine the total basin hydrograph. Areas shall be selected to represent homogenous land use/development units.

#### Time of Concentration

Time of concentration,  $T_c$ , is the time for a theoretical drop of water to travel from the furthest point in the drainage basin to the facility being designed. In this case,  $T_c$  is derived by calculating the overland flow time of concentration and the channelized flow time of concentration.  $T_c$  depends on several factors, including ground slope, ground roughness, and distance of flow. The formula for determining  $T_c$  is found in the Standard Equations.

#### Runoff Curve Numbers

Runoff curve numbers were developed by the NRCS after studying the runoff characteristics of various types of land. Curve numbers (CN) were developed to reduce diverse characteristics such as soil type, land usage, and vegetation into a single variable for use in runoff calculations. The runoff curve numbers approved by OLWS for water quantity/quality calculations are included in Table 20.

The curve numbers presented in Table 20 are for wet antecedent moisture conditions. Wet conditions assume previous rainstorms have reduced the capacity of soil to absorb water. Given the frequency of storms in Clackamas County, wet conditions are most likely, and result in conservative hydrographic values.

## Design Storm

The SBUH method also requires a design storm to perform the runoff calculations. For flow control calculations, OLWS uses an NRCS Type 1A 24-hour storm distribution. The rainfall depths for 2-year through 100-year storm events are shown in Table 18.

Table 18. OLWS Design Storms

| Design Storm/Recurrence Interval (years) | 24-Hour Rainfall Depth (inches) |
|--|---------------------------------|
| Water Quality                            | 1.0                             |
| 2-year                                   | 2.4                             |
| 5-year                                   | 2.85                            |
| 10-year                                  | 3.2                             |
| 25-year                                  | 4.0                             |
| 50-year                                  | 4.13                            |
| 100-year                                 | 4.8                             |

## Soils Information

Soils information can be found in the current NRCS Soil Survey for Clackamas County, Oregon. Soils information may be obtained electronically from the NRCS Soil Survey at <https://websoilsurvey.nrcs.usda.gov/app/>.

1. Select “Start WSS”.
2. Under the “Area of Interest”, use the State and County drop down menus to select Oregon and Clackamas and select “View” and the Area of Interest Interactive Map will show Clackamas County.
3. Use the Area of Interest Interactive Map to navigate to the project site location.
4. Determine the areas of the site that fall under each of the four hydrologic soil groups in Table 19.

Table 19. Hydrologic Soil Groups

|                |  |
|----------------|--|
| <b>Group A</b> | Soils having a high infiltration rate (low runoff potential) when thoroughly wet (deep, well drained to excessively drained sands or gravelly sands)   |
| <b>Group B</b> | Soils having a moderate infiltration rate when thoroughly wet (moderately deep or deep, moderately well drained, or well drained soils that have moderately fine texture to moderately coarse texture) |

|                |  |
|----------------|--|
| <b>Group C</b> | Soils having a slow infiltration rate when thoroughly wet (soils having a layer that impedes the downward movement of water or soils of moderately fine texture or fine texture)   |
| <b>Group D</b> | Soils having a very slow infiltration rate (high runoff potential) when thoroughly wet (clays that have a high shrink-swell potential, soils that have a high water table, soils that have a claypan or clay layer at or near the surface, and soils that are shallow over nearly impervious material) |

## Standard Equations

---

MANNING'S EQUATION: (Open Channel Flow)

$$Q = \left( \frac{1.486}{n} \right) A R^{2/3} S^{1/2}$$

Manning's Equation for circular pipe  
flowing full

$$\begin{cases} Q = \frac{0.463}{n} D^{2/3} S^{1/2} \\ V = \frac{0.590}{n} D^{2/3} S^{1/2} \end{cases}$$

$$V = \left( \frac{1.486}{n} \right) R^{2/3} S^{1/2}$$

|   |   |
|---|---|
| Q | Quantity of flow, cubic feet per second   |
| V | Velocity of flow, feet per second   |
| n | Manning's coefficient of roughness (see Table 21 and Table 22 of these Standards) |
| A | Cross-sectional area, square feet   |
| R | Hydraulic radius (area of flow divided by wetted perimeter), feet                 |
| S | Slope of the pipe or energy line, feet per foot                                   |
| D | Diameter of pipe, feet  |

---

RATIONAL METHOD: (Stormwater Design Flows)

Q = CIA (Max. drainage area=100 acres-- Max. time: 60 minutes)

|   |   |
|---|---|
| Q | Quantity of runoff, cubic feet per second                                   |
| C | Coefficient of runoff (ratio of runoff to rainfall), percent (See Table 21) |
| I | Intensity of rainfall, inches per hour                                      |
| A | Area of tributary drainage basin, acres                                     |

---

GUTTER FLOW CAPACITY: (Manning's Equation Modified)

$$Q = 0.56 \frac{1}{n} S^{0.5} d^{2.67} \quad \text{or} \quad Q = \frac{0.56}{n} S_x^{1.67} S^{0.5} T^{2.67} \quad V = \frac{1.12}{n} S^{0.5} S_x^{0.67} T^{2.67}$$

|                |   |
|----------------|---|
| Q              | Quantity of flow, cubic feet per second                             |
| S <sub>x</sub> | Street cross slope, feet per foot                                   |
| S              | Street longitudinal slope, feet per foot                            |
| n              | Manning's coefficient of roughness for the gutter, (normally 0.018) |
| D              | Depth of flow at the curb, feet                                     |
| T              | Total width of flow in the gutter, feet                             |

---



---

TIME OF CONCENTRATION: (Overland Stormwater Flow)

$$T_t = L/60V \text{ (for conversion of velocity to travel time)}$$

$$T_c = T_{11} + T_{12} + \dots + T_{1m}$$

$$T_t = \frac{0.42 (nL)^{0.8}}{1.58 (S)^{0.4}} \text{ (Manning's kinematic solution for sheet flow less than 300 feet)}$$

$$V = 16.1345 (S)^{0.5} \text{ (Unpaved surfaces)}$$
$$V = 20.3282 (S)^{0.5} \text{ (Paved surfaces)}$$

{ Shallow concentrated flow for slopes less than 0.005 ft/ft. For  
steeper slopes, see Figure 13.

Tt Travel time, minutes

L Flow length, feet

V Average velocity of flow, *feet per second*

60 Conversion factor from seconds to minutes

Tc *Total time of concentration, minutes* {minimum Tc = 5.0 minutes}

n Manning's roughness coefficient for various surfaces, (see Table 21 And Table 22)

S Slope of the hydraulic grade line (land or watercourse slope), feet per foot

1.58 A factor derived from Ref. No. 8 (P2, from 2-year, 24-hr precipitation chart, for the Portland, Oregon area [P 2<sup>0.5</sup> = 2.5<sup>0.5</sup>=1.58])

---

Figure 13. Average Velocities for Shallow Concentrated Flow

Figure from Technical Release 55: Urban Hydrology for Small Watersheds, published by the United States Department of Agriculture, Natural Resources Conservation Service, Conservation Engineering Division (1986, updated 1999).

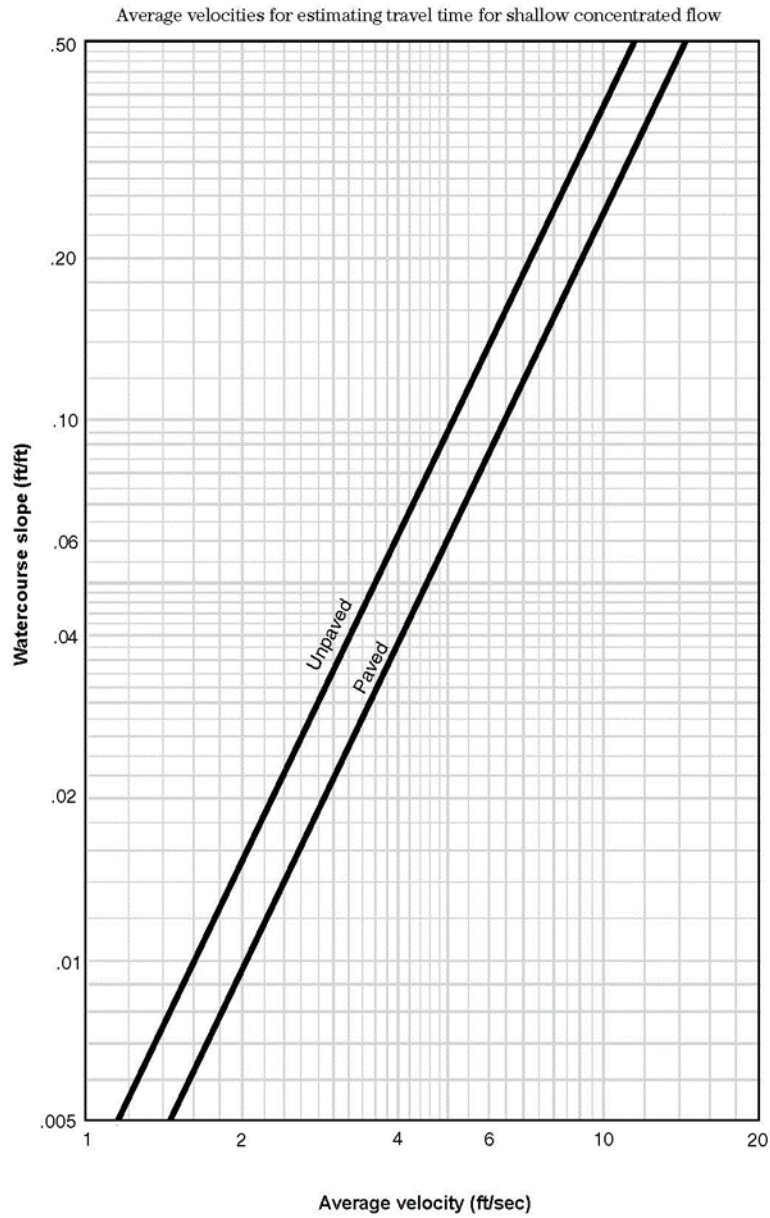

Table 20. Runoff Curve Numbers<sup>2</sup>

| Description  | Curve Numbers for Hydrological Soil Groups |    |    |    |
|--|--|----|----|----|
|  | A  | B  | C  | D  |
| <b>Open space (lawns, parks, golf courses, cemeteries)</b> |  |    |    |    |
| Poor condition (< 50% grass coverage)                      | 68   | 79 | 86 | 89 |
| Fair condition (50 to 75% grass coverage)                  | 49   | 69 | 79 | 84 |
| Good condition (>75% grass coverage)                       | 39   | 61 | 74 | 80 |
| <b>Impervious Areas</b>                                    |  |    |    |    |
| Paved areas (parking lots, roofs, driveways)               | 98   | 98 | 98 | 98 |
| Streets and roads  |  |    |    |    |
| Paved with curbs   | 98   | 98 | 98 | 98 |
| Paved with open ditches                                    | 83   | 89 | 92 | 93 |
| Gravel   | 76   | 85 | 89 | 91 |
| Dirt   | 72   | 82 | 87 | 89 |
| <b>Urban Districts</b>                                     |  |    |    |    |
| Commercial and business (85% impervious)                   | 89   | 92 | 94 | 95 |
| Industrial (72% impervious)                                | 81   | 88 | 91 | 93 |
| <b>Residential districts by average lot size</b>           |  |    |    |    |
| 1/8 acre or less (65% impervious)                          | 77   | 85 | 90 | 92 |
| 1/4 acre (38% impervious)                                  | 61   | 75 | 83 | 87 |
| 1/3 acre (30% impervious)                                  | 57   | 72 | 81 | 86 |
| 1/2 acre (25% impervious)                                  | 54   | 70 | 80 | 85 |
| <b>Woods (Good Hydrologic Condition)</b>                   | 70*  |    |    |    |

\* CN for Predeveloped Forest Condition is assumed to be equivalent to Woods condition with Hydrologic Soil Group C.

<sup>2</sup> Urban Hydrology for Small Watersheds (TR-55), USDA Soil Conservation Service Engineering Division (1986).

*Table 21. Runoff Coefficients for Developed Areas (Average Impervious Area Percent for Typical Land Uses, Ground Slopes, and Hydrological Soil Groups)*

| % Impervious | Soil Type | Drainage Area Slope |           |          | Typical Land Use   |
|--------------|-----------|---------------------|-----------|----------|--|
|              |           | Under <5%           | 5% to 10% | Over 10% |  |
| 0-10         | A         | 0.19                | 0.24      | 0.29     | Open Spaces, Parks, Cemeteries, Playgrounds                      |
|              | B         | 0.24                | 0.30      | 0.36     |  |
|              | C         | 0.29                | 0.36      | 0.44     |  |
|              | D         | 0.33                | 0.43      | 0.52     |  |
| 11-20        | A         | 0.26                | 0.31      | 0.36     | Residential (1 unit/20,000 square feet or greater)               |
|              | B         | 0.30                | 0.37      | 0.43     |  |
|              | C         | 0.35                | 0.42      | 0.50     |  |
|              | D         | 0.39                | 0.48      | 0.57     |  |
| 21-30        | A         | 0.34                | 0.39      | 0.44     | Residential (1 unit/10,000 square feet)                          |
|              | B         | 0.37                | 0.44      | 0.50     |  |
|              | C         | 0.41                | 0.49      | 0.56     |  |
|              | D         | 0.45                | 0.54      | 0.62     |  |
| 31-40        | A         | 0.41                | 0.46      | 0.51     | Residential (1 unit/1,000 – 7,000 square feet)                   |
|              | B         | 0.44                | 0.50      | 0.56     |  |
|              | C         | 0.47                | 0.55      | 0.61     |  |
|              | D         | 0.51                | 0.59      | 0.67     |  |
| 41-50        | A         | 0.49                | 0.54      | 0.59     | Residential (1 unit/less than 1,000 square feet)                 |
|              | B         | 0.52                | 0.57      | 0.63     |  |
|              | C         | 0.55                | 0.61      | 0.67     |  |
|              | D         | 0.57                | 0.65      | 0.72     |  |
| 51-60        | A         | 0.56                | 0.61      | 0.66     | Mixed-Use Residential<br>Residential Streets<br>Schools/Campuses |
|              | B         | 0.58                | 0.64      | 0.70     |  |
|              | C         | 0.61                | 0.67      | 0.74     |  |
|              | D         | 0.63                | 0.70      | 0.77     |  |

|        |   |      |      |      |                          |
|--------|---|------|------|------|--------------------------|
| 61-70  | A | 0.64 | 0.69 | 0.74 | Mixed Use Residential    |
|        | B | 0.66 | 0.72 | 0.77 | Mixed-Use Commercial     |
|        | C | 0.67 | 0.74 | 0.80 | Collector Streets        |
|        | D | 0.69 | 0.76 | 0.82 |                          |
| 71-80  | A | 0.71 | 0.76 | 0.81 | Mixed Use Residential    |
|        | B | 0.72 | 0.78 | 0.83 | Mixed-Use Commercial     |
|        | C | 0.73 | 0.80 | 0.85 | Arterial Streets         |
|        | D | 0.75 | 0.81 | 0.87 | Hospitals                |
| 81-90  | A | 0.79 | 0.84 | 0.89 | Commercial Centers       |
|        | B | 0.80 | 0.85 | 0.90 | High Density Residential |
|        | C | 0.81 | 0.86 | 0.91 |                          |
|        | D | 0.81 | 0.87 | 0.92 |                          |
| 91-100 | A | 0.86 | 0.91 | 0.96 | Commercial Centers       |
|        | B | 0.87 | 0.92 | 0.97 | High Density Residential |
|        | C | 0.87 | 0.92 | 0.97 | Arterial Streets         |
|        | D | 0.88 | 0.92 | 0.97 |                          |

① Any of the runoff coefficients may be adjusted to the nearest 0.05 to reflect any departure from these typical values. Any adjustment must be applied uniformly throughout a drainage area.

② Soil Types: A = gravel and sandy loam; B = light clay and silt loam; C = tight clay.

③ The land uses are typical for a given percent of impervious surface. Where there is or will be any significant variation from typical conditions, another percentage range should be used.

Source: City of Portland, 2020 Sewer and Drainage Facilities Manual

Table 22. Runoff Coefficients for Undeveloped Areas (General Surface Characteristics, Ground Slope, and Hydrologic Soil Groups)

| Surface Characteristics   | Soil Type | Drainage Area Slope |            |          |
|---------------------------|-----------|---------------------|------------|----------|
|                           |           | Under 5%            | 5% to 10 % | Over 10% |
| Woodland                  | A         | 0.10                | 0.15       | 0.20     |
|                           | B         | 0.15                | 0.25       | 0.30     |
|                           | C         | 0.30                | 0.35       | 0.40     |
| Lawn, Pasture, and Meadow | A         | 0.15                | 0.20       | 0.25     |
|                           | B         | 0.25                | 0.30       | 0.35     |
|                           | C         | 0.30                | 0.40       | 0.50     |
| Cultivated Land           | A         | 0.25                | 0.35       | 0.50     |
|                           | B         | 0.40                | 0.55       | 0.70     |
|                           | C         | 0.50                | 0.65       | 0.80     |
| Gravel Areas and Walks    |           |                     |            |          |
|                           |           |                     |            |          |
| Loose                     |           | 0.30                | 0.40       | 0.50     |
| Packed                    |           | 0.70                | 0.75       | 0.80     |
| Pavement and Roof         |           | 0.90                | 0.95       | 1.00     |

## Hydraulics

The following figures are from the Oregon Department of Transportation Hydraulics Design Manual (2014), Chapter 7, Appendix A.

Figure 9. Rainfall I-D-R Curve Zone Map

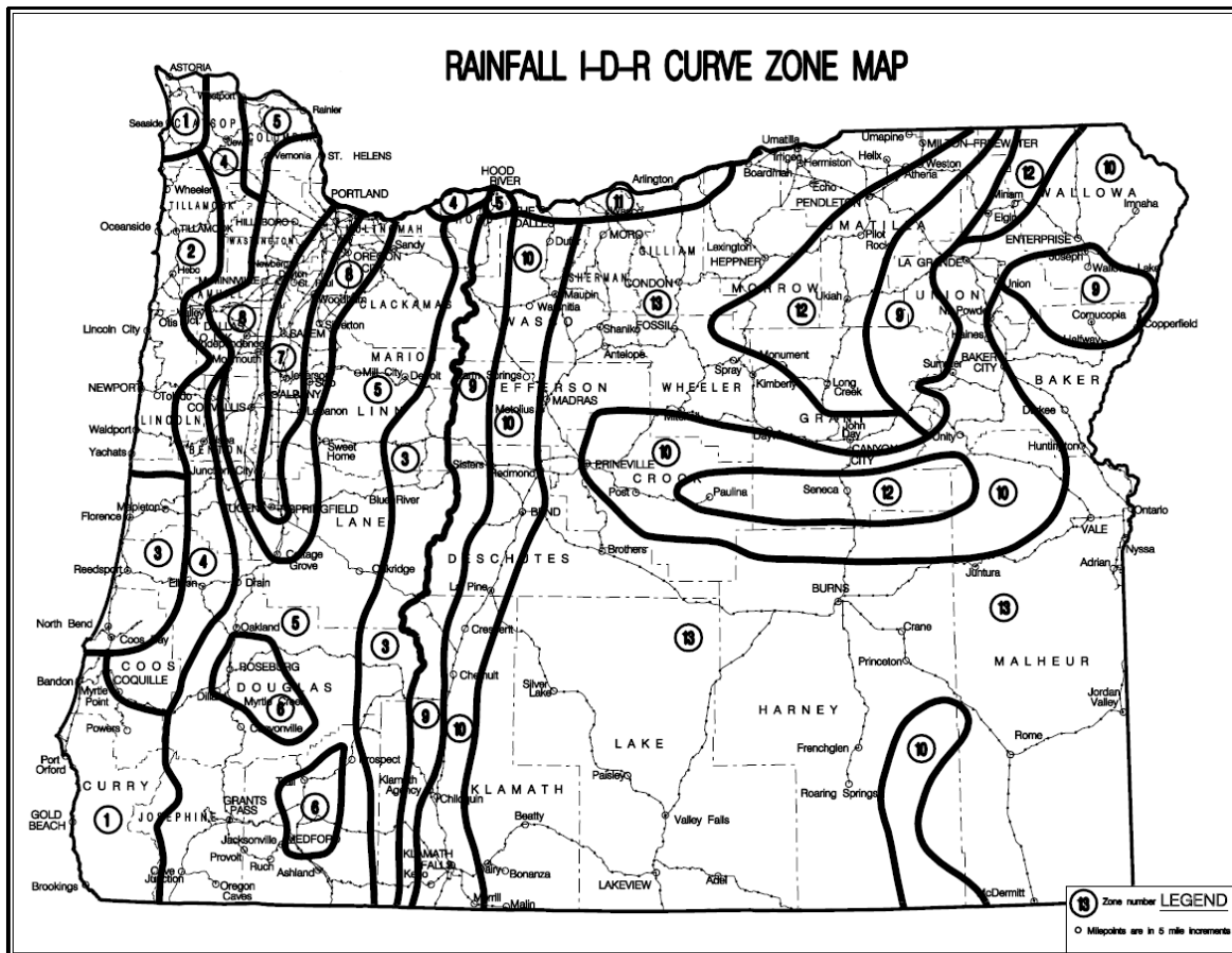

Figure 10. Rainfall Intensity Recurrence Curves (Zone 5)

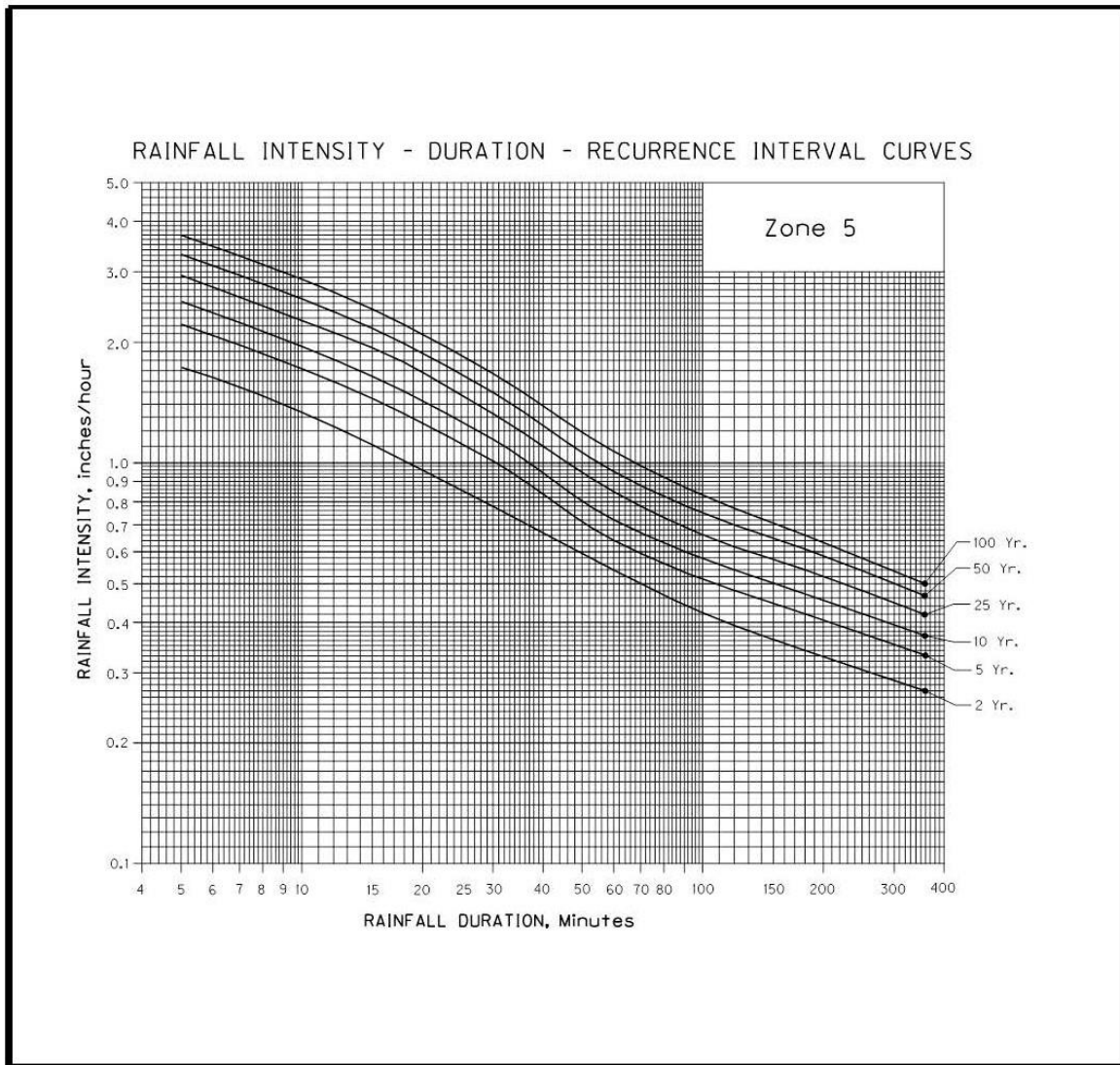



Figure 11. Rainfall Intensity Recurrence Curves (Zone 7)

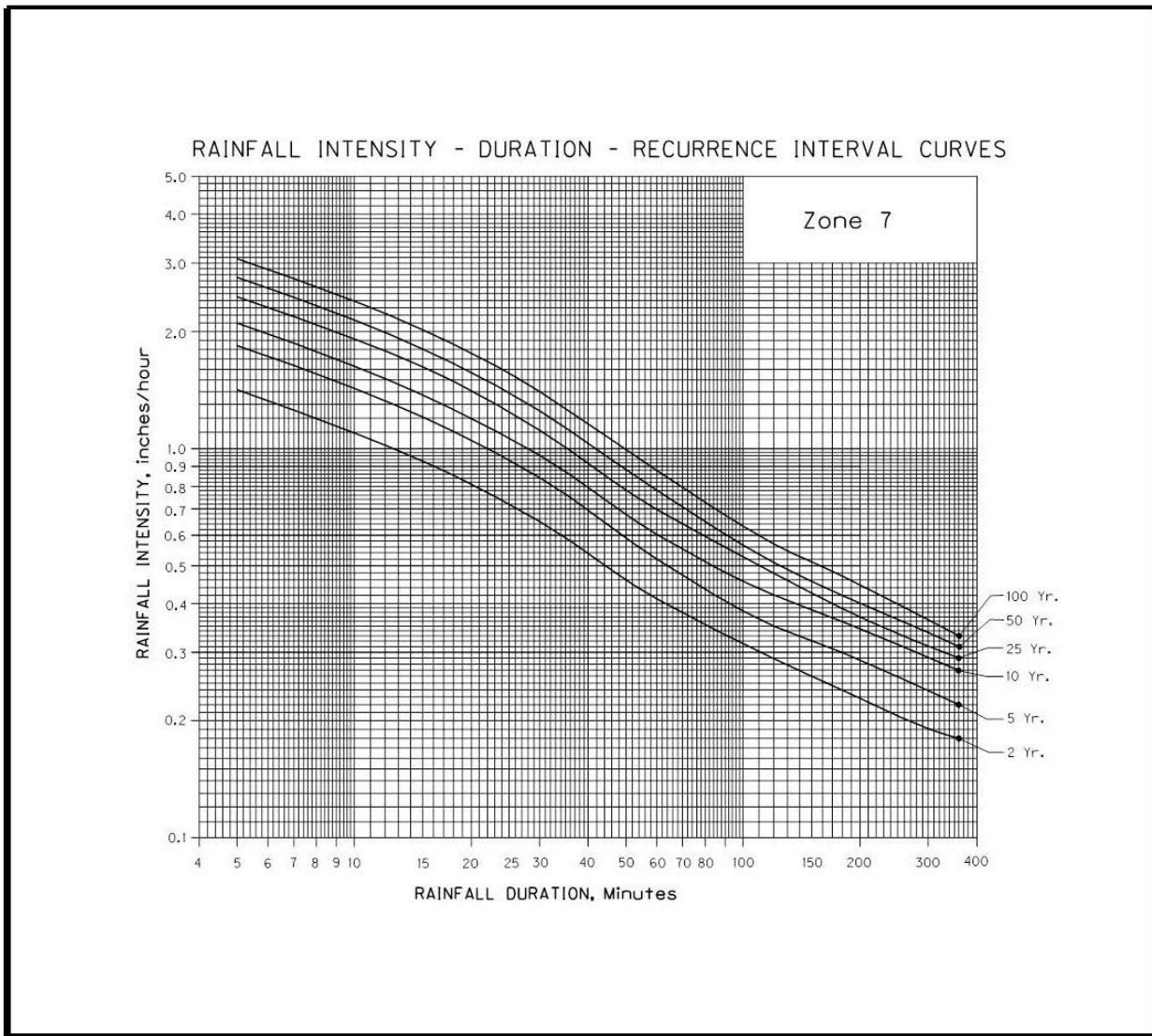
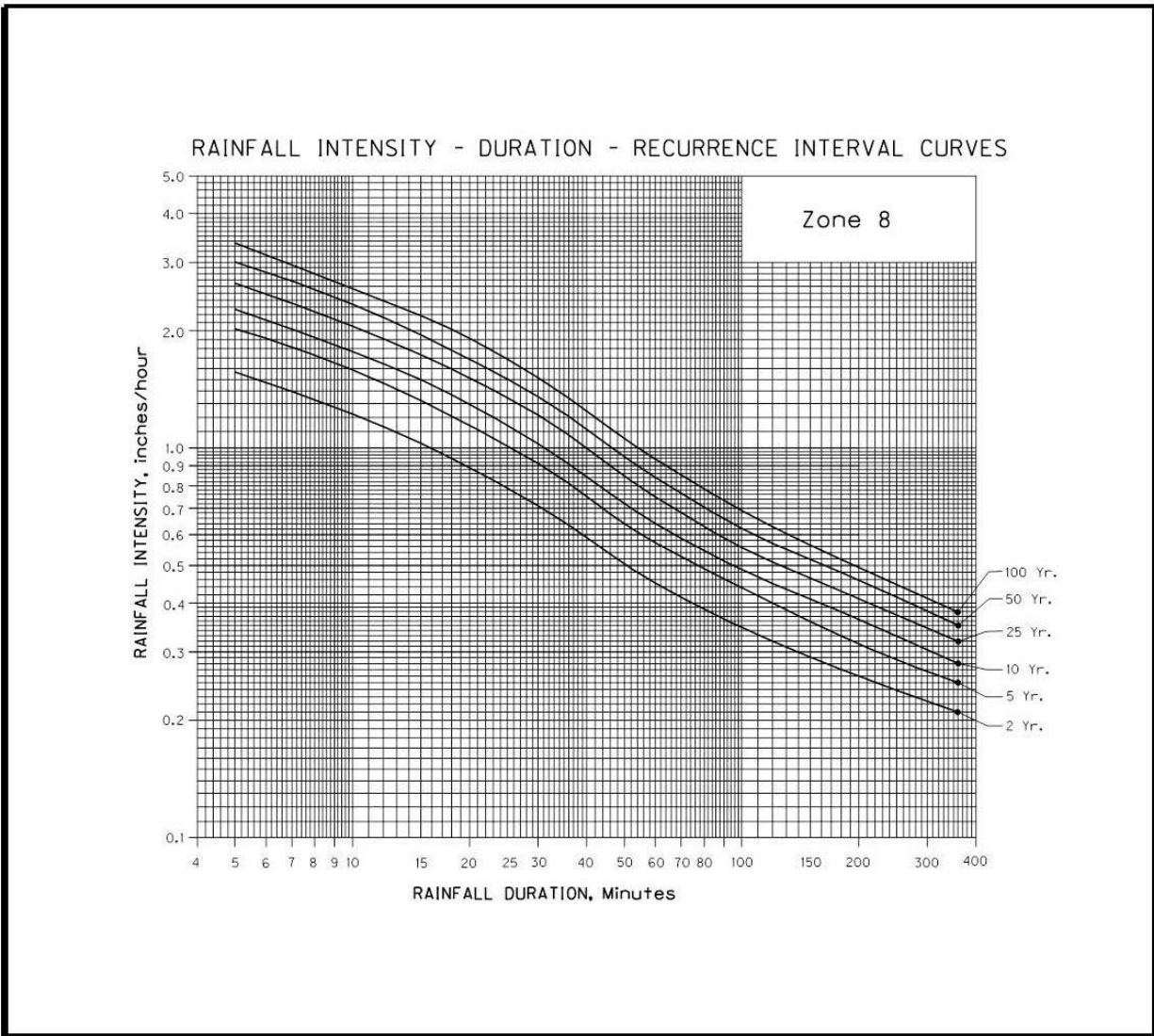

Figure 12. Rainfall Intensity Recurrence Curves (Zone 8)



## NOAA Isopluvial Maps

The following figures are from the Precipitation-Frequency Atlas of the Western United States (Volume X – Oregon), published by the U.S. Department of Commerce, National Oceanic and Atmospheric Administration, National Weather Service (1973).

Figure 13. Isopluvials of 2-YR, 24-HR Precipitation in Tenths of an Inch

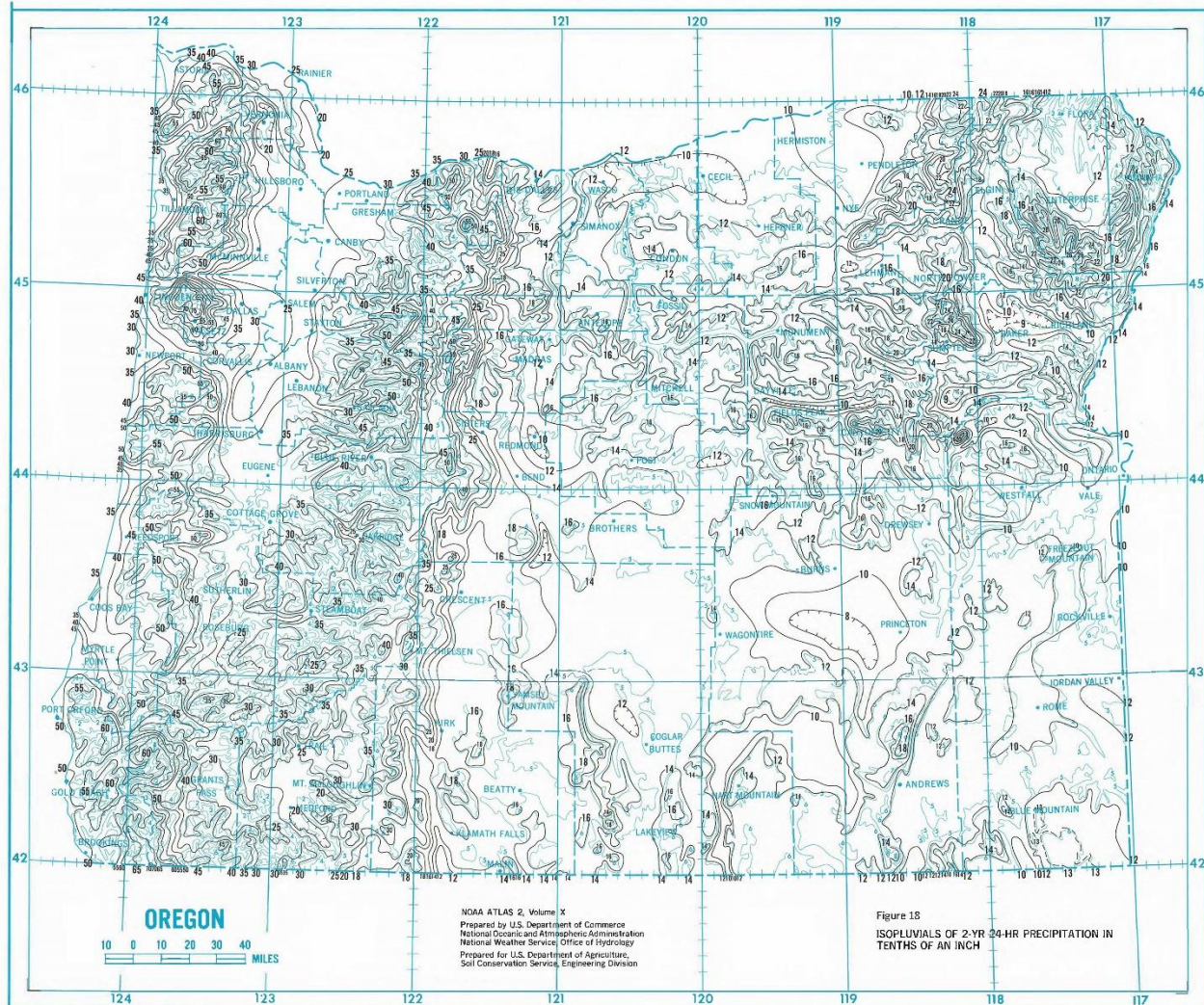







Figure 15. Isopluvials of 10-yr, 24-hr Precipitation in Tenths of an Inch

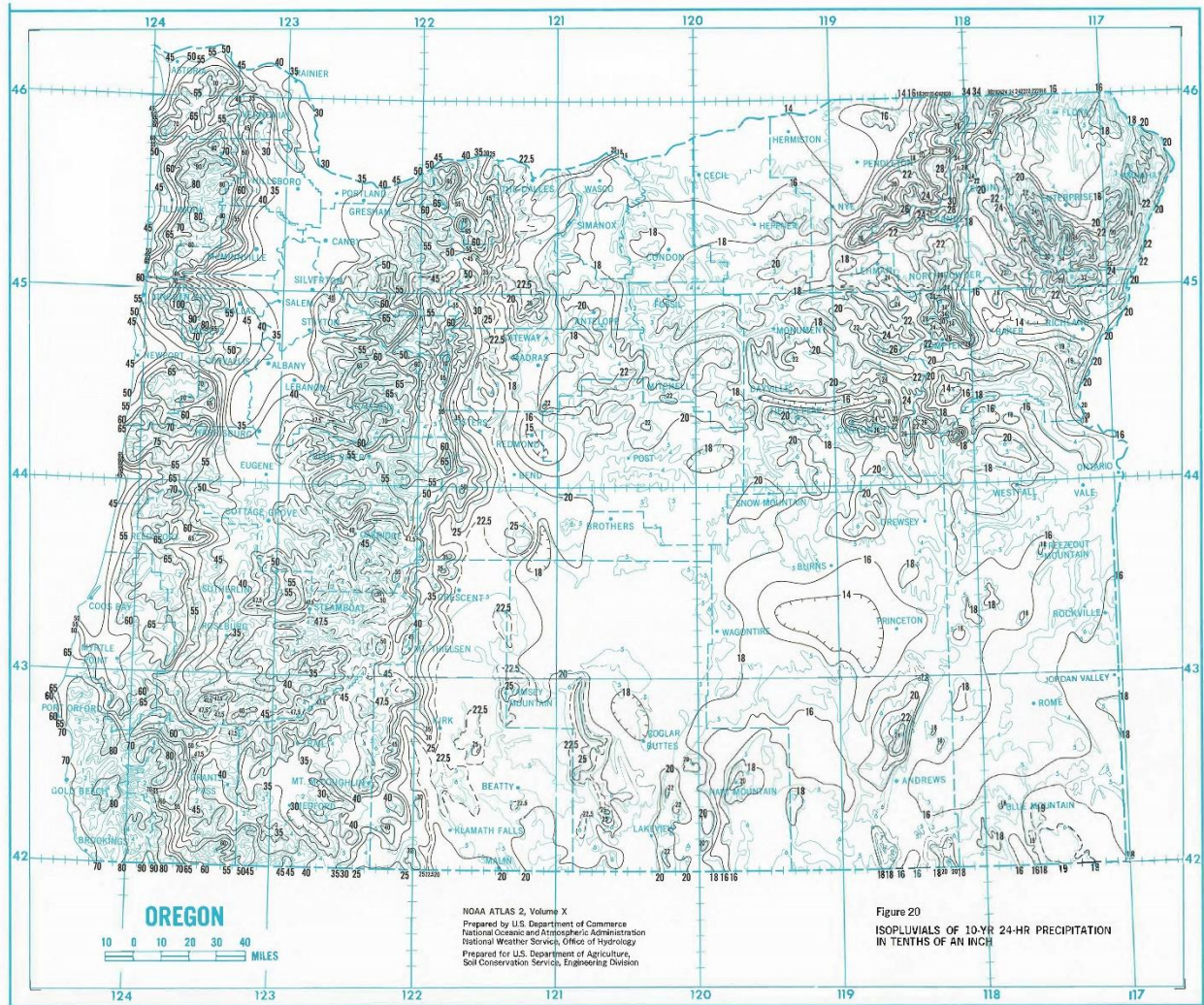



Figure 16. Isopluvials of 25-yr, 24-hr Precipitation in Tenths of an Inch

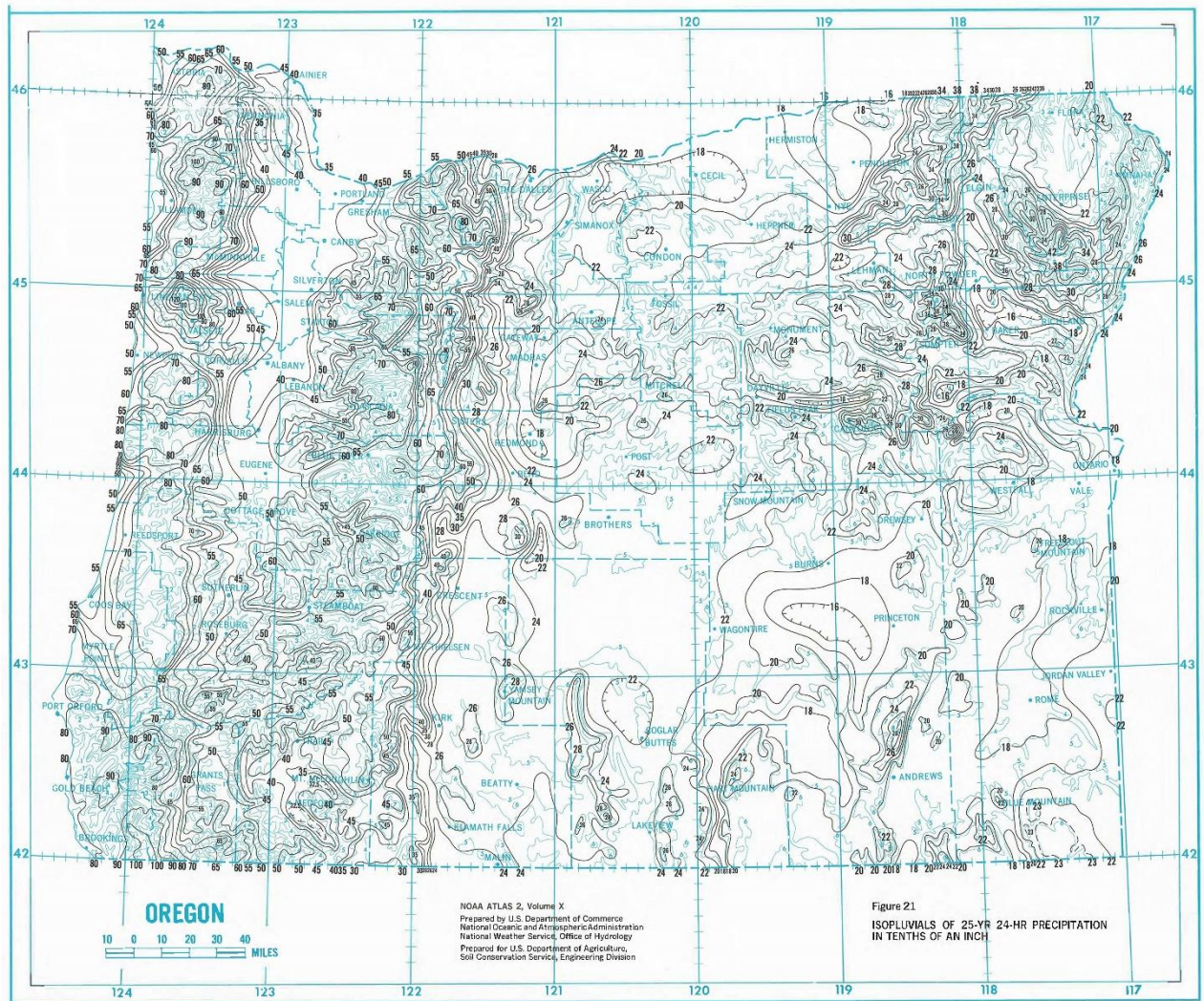
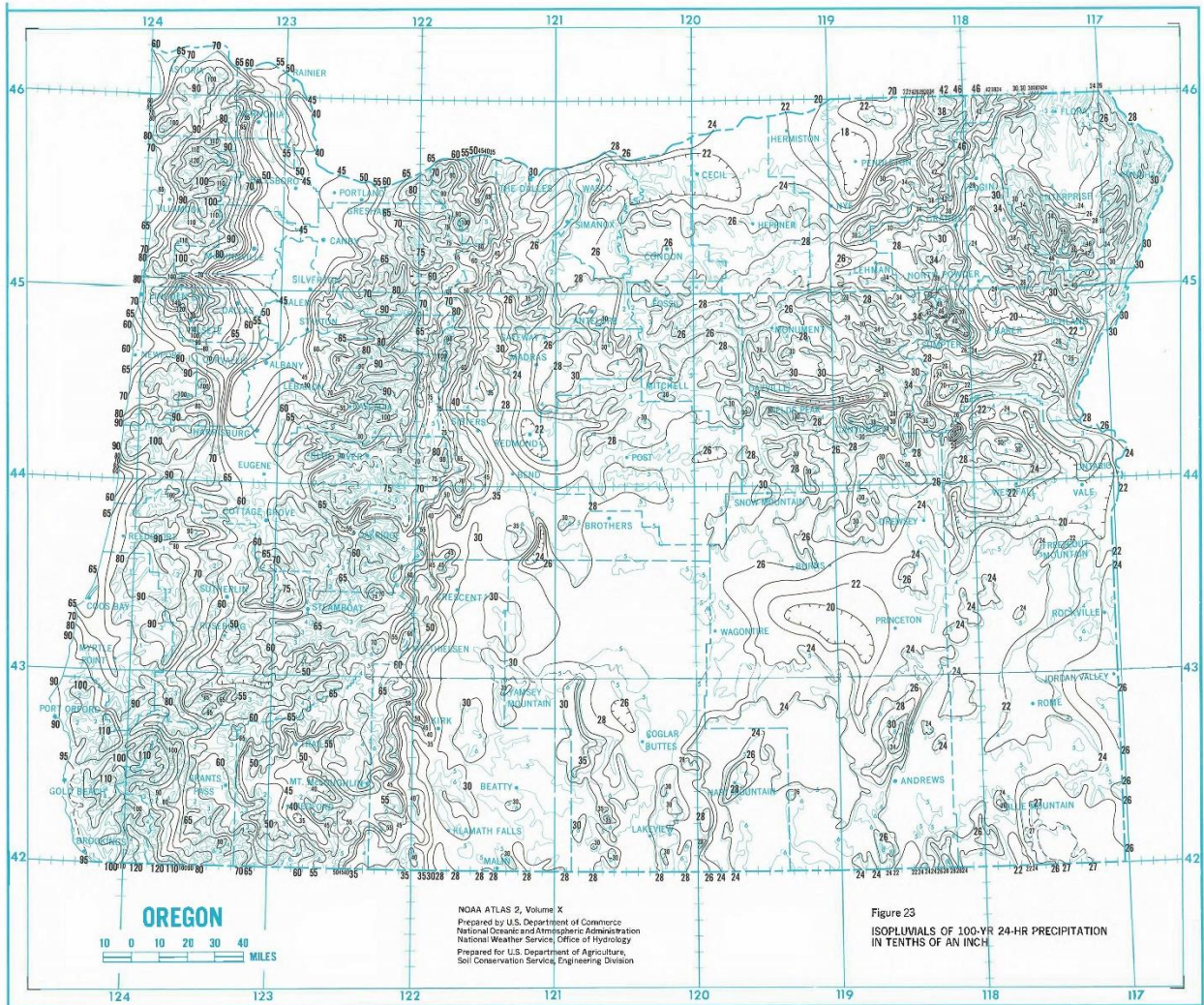







Figure 18. Isopluvials of 100-yr, 24-hr Precipitation in Tenths of an Inch





## **Appendix E OAK LODGE SIMPLIFIED METHOD**

---

Oak Lodge uses City of Portland forms for infiltration calculation and infiltration design detail drawings. Oak Lodge's sizing sheet is based off of flow control calculation sizing from the BMP sizing tool and is variable according to soil type which is determined by observed infiltration rate.

City of Portland forms and drawings are shown here for reference. The most current version(s) are adopted even if not shown.



# SIMPLIFIED APPROACH FORM

## PROJECT INFORMATION WORKSHEET

Project/Permit Number: \_\_\_\_\_

Land Use Case Number: \_\_\_\_\_

Contact Name: \_\_\_\_\_

Phone: \_\_\_\_\_

Email: \_\_\_\_\_

Site Address/R Number(s) for all parcels:  
 \_\_\_\_\_  
 \_\_\_\_\_

Project Description: \_\_\_\_\_

Existing impervious area: \_\_\_\_\_ f<sup>2</sup>

Total NEW impervious area: \_\_\_\_\_ f<sup>2</sup>

**SITE CHARACTERISTICS**

S.1 Do slopes exceed 20% anywhere within the project area?  Yes  No

S.2 Are there springs, seeps, or a high groundwater table within the project area?  Yes  No

S.3 Geotech Report?  Yes  No

S.4 Infiltration Test?  Yes  No

See back of form for required certifications.

### SIMPLE PIT INFILTRATION TEST PROCEDURE

The person performing this test does not need a professional credential.

**Test instructions:**

1. Conduct the test in and/or near the location of the proposed infiltration facility.
2. Excavate a 2' by 2' pit to a depth of: 2' below grade for facilities less than 2' deep or 3' below grade for facilities greater than 2' deep. Check for standing water or hardpan soil preventing excavation. If either is present, document conditions on this form and **do not** proceed with the test.
3. Fill the pit with at least 12 inches of water and record the initial water depth and the time when the test starts. Check the water depth at regular intervals until all of the water has been absorbed or for 1 hour, whichever occurs first. Record the time and final water depth at the end of the test.
4. Repeat the process two more times for a total of three rounds. Conduct the tests in succession to accurately characterize the soil's infiltration rates at different levels of saturation. The third test provides the best measure of the infiltration rate when saturated.
5. Record infiltration test data in the table below and certify the results. Uncertified test results will not be accepted.

**Required Infiltration Testing**

Date of Test: \_\_\_\_\_

Depth of Excavation (ft): \_\_\_\_\_

Depth of Proposed Facility: \_\_\_\_\_

**Test Pit Location (site plan sketch)**

*Key information to include: 1) Site or parcel; 2) Adjacent road(s) or cross street(s); 3) Test pit location with dimensions*

north

|                                       | TEST 1 | TEST 2 | TEST 3 |
|---------------------------------------|--------|--------|--------|
| A. Time (of day)                      |        |        |        |
| B. Duration (minutes; 1 hour maximum) |        |        |        |
| C. Initial Water Depth (inches)       |        |        |        |
| D. Final Water Depth (inches)         |        |        |        |
| E. Infiltration Rate* (inches/hour)   |        |        |        |

\*Infiltration Rate = Initial Depth (in) - Final Depth (in) / Duration of Test (hours). hours = minutes/60

# SIMPLIFIED APPROACH FORM

## PROPOSED STORMWATER FACILITIES

### Proposed Stormwater Facilities

**Please note:** Each individual tax lot is required to manage the stormwater runoff it generates on the same lot to the maximum extent feasible (for new construction or redevelopment). The following table includes accepted Simplified Approach facilities as described in Chapters 2 & 3 of the *2020 Stormwater Management Manual*. Copies of the manual are available online at [www.portlandoregon.gov/bes/SWMM](http://www.portlandoregon.gov/bes/SWMM).

| STORMWATER FACILITY TYPE  | AREA DRAINING TO FACILITY (SF) | FACILITY SIZING FORMULA  | FACILITY SIZE (surface area of facility) |
|---|--------------------------------|--|--|
| Ecoroof   |                                | Area x 1 (1:1 ratio)   |  |
| Pervious Pavement   |                                | Area x 1 (1:1 ratio)   |  |
| Rain garden   |                                | Area x 0.10  |  |
| Basin   |                                | Area x 0.09  |  |
| Planter   |                                | Area x 0.06  |  |
| Filter Strip  |                                | See sizing table in SWMM Section 3.3.2.1   |  |
| Driveway Center Strip   |                                | Min. width is 3 ft; max. length is 50 ft if slope is 10-15% (max. slope is 15%).   |  |
| Drywell   |                                | See Maximum Catchment Area Managed by a Single Drywell Table below   | (Drywell diameter, depth number)         |
| Soakage Trench  |                                | 25 ft <sup>2</sup> of soakage trench for every 500 ft <sup>2</sup> of impervious area. (Depth = 1.5 ft; width & length vary) |  |
| Surface Sand Filter   |                                | Area x 0.06  |  |
| <b>TOTAL IMPERVIOUS AREA</b><br>(Managed, new, and redeveloped) |                                | Total impervious area must equal the total <b>NEW AND REDEVELOPED</b> impervious area being proposed.                        |  |

| Maximum Catchment Area Managed by a Single Drywell (ft <sup>2</sup> ) |                     |                       |                       |
|---|---------------------|-----------------------|-----------------------|
| MATERIAL  | PLASTIC             | CONCRETE              | CONCRETE              |
| Ring Diameter   | 24 inches           | 28 inches             | 48 inches             |
| 2 ft deep   | 500 ft <sup>2</sup> | NA                    | NA                    |
| 5 ft deep   | NA                  | 1,000 ft <sup>2</sup> | 2,500 ft <sup>2</sup> |
| 10 ft deep  | NA                  | 2,500 ft <sup>2</sup> | 4,500 ft <sup>2</sup> |
| 15 ft deep  | NA                  | 3,500 ft <sup>2</sup> | 5,000 ft <sup>2</sup> |

No more than 2 plastic drywells allowed per catchment area.

### Required Certifications

#### SIMPLE PIT TEST

\_\_\_\_\_  
Name of Tester

\_\_\_\_\_  
Signature of Tester

\_\_\_\_\_  
Date

#### PERSON RESPONSIBLE FOR APPLICATION ACCURACY

\_\_\_\_\_  
Contact Name—Printed

\_\_\_\_\_  
Signature

\_\_\_\_\_  
Date

# Simplified Storm Facility Sizing



This form is to be used to size stormwater facilities following the Simplified Method. The following table contains acceptable stormwater sizing factors for stormwater facilities based

Name: \_\_\_\_\_ Site Address: \_\_\_\_\_

Impervious Area from Development (sf):

Infiltration Rate (in/hr):  Soil Type\*  D1

\* note that facilities with type C and D soils require an underdrain and a 1/2" orifice.

**Instructions:**

1. Determine the amount of impervious area (in square feet) to be managed by each stormwater facility
2. Multiply the Impervious Area Managed by the sizing factor for your soil type to determine the Facility Size needed.
3. Total Impervious Area Managed must match Impervious Area from Development

| Facility Type      |                | Facility Size (sf) |              |
|--------------------|----------------|--------------------|--------------|
| Drawing SW-121     | Rain Garden    | 0                  |              |
| Drawing SW-140&141 | Planter        | 0                  |              |
| Drawing SW-170     | Soakage Trench | 0                  |              |
| Drawing SW-180     | Drywell        | diameter (in)      | 28"    48"   |
|                    |                | depth (ft)         | #N/A    #N/A |

# SECTION 3—WASTEWATER DESIGN AND CONSTRUCTION STANDARDS

## TABLE OF CONTENTS

|       |  |    |
|-------|--|----|
| 3.0   | SANITARY SEWERS .....                      | 1  |
| 3.0.1 | General Design Requirements .....          | 1  |
| 3.0.2 | Pipe Materials and Size .....              | 1  |
| 3.0.3 | Minimum Design Criteria .....              | 2  |
| 3.0.4 | Alignment and Cover.....                   | 3  |
| 3.0.5 | Structures .....                           | 6  |
| 3.0.6 | Laterals .....                             | 7  |
| 3.0.7 | Connection to Existing Sewer .....         | 9  |
| 3.1   | SEWAGE PUMP STATION DESIGN STANDARDS ..... | 10 |
| 3.1.1 | General.....                               | 10 |
| 3.1.2 | Design.....                                | 10 |
| 3.1.3 | Materials .....                            | 11 |
| 3.1.4 | Construction.....                          | 12 |
| 3.2   | SANITARY SEWER CONSTRUCTION .....          | 12 |
| 3.2.1 | Pipe and Fittings.....                     | 12 |
| 3.2.2 | Manholes and Concrete Structures .....     | 23 |
| 3.2.3 | Work on Existing Sanitary Sewers.....      | 29 |

## 3.0 SANITARY SEWERS

---

### 3.0.1 General Design Requirements

**Performance Standards:** Sanitary sewer system design shall meet the policies and guidelines of the adopted OLWS Rules, Regulations and Design and Construction Standards and its updates.

Sanitary sewer systems shall be designed to provide gravity service to all areas of development unless approved by District Engineer as stated below.

Sanitary sewer system capacity shall be designed for ultimate development density of the tributary area. The system shall allow for future system extension and for future development.

Sanitary sewers shall be designed to remove the domestic sewage from residential, commercial, or industrial buildings, and all public and private establishments.

Stormwater, including street, roof, or footing drainage, shall not be discharged into the sanitary sewer system but shall be removed by a system of storm drains or by some other method separate from the sanitary sewer system.

Unpolluted or noncontact cooling waters shall not be discharged into sanitary sewers. The overflow drains and filter backwash lines of swimming pools and hot tubs shall drain into a sanitary sewer.

In general, sewer systems shall be designed to allow for future loads and for ultimate development of the specific drainage area or basin concerned.

As a condition of sewer service, all developments will be required to provide public sewers to adjacent upstream parcels in order to provide for an orderly development of the drainage area. This shall include street frontage of the property to adjoining properties when the main is located in the street right-of-way. This shall include trunk sewers that are oversized to provide capacity for upstream development.

All sewer mainlines shall be located within the public right-of-way or public easement as directed by the District Engineer. These lines are placed in the public streets and right-of-way for ease of maintenance and access, control of the facility, operation of the facility, and to provide required replacement and/or repair.

Design shall comply with Oregon Department of Environmental Quality sewer design guidelines<sup>1</sup>, and the requirements of OLWS.

District Engineer approval will be required for any sanitary lift or pump stations.

### 3.0.2 Pipe Materials and Size

All public sanitary sewers including mains and laterals shall be constructed with PVC SDR 35 pipe as specified in Section 3.2. The District Engineer shall have discretion for requiring

---

<sup>1</sup> OAR 340, and Division 52 at time of adoption

alternative pipe materials. Class 50 ductile-iron pipe, C900 PVC pipe, or HDPE SDR 11 (new) or SDR 17 (bursting) pipe may be required with authorization from the District Engineer. Circumstances include but are not limited to areas of unstable soils, high groundwater, shallow rock, being located outside public roadways, and railroad crossings or creek crossings.

Private sanitary sewers shall meet the appropriate sections of the Oregon Plumbing Specialty Code.

All sanitary sewer main lines shall be a minimum diameter of 8 inches. A 6-inch diameter sewer will be allowed only with the District Engineer’s approval and shall be submitted as a variance request.

New and reconstructed light rail and freight rail construction may require improvements to the sanitary sewer system at utility crossing locations. All existing pipes or pipes on the second half of useful life within the rail zones shall be replaced to current standards. Metallic or conductive pipe materials are not approved pipe materials at rail crossings. Pipes are to be centered under rail tracks to avoid joints underneath rail lines. All new pipe installations must identify practical future replacement options for the sewer pipe under rails in case of future failure of utility. All pipes shall be sized for full build-out and future flows. This sizing includes allowance for trenchless technologies. Where lining is anticipated, pipe size shall account for future lining thickness.

### 3.0.3 Minimum Design Criteria

In general, sewer systems should be designed to care for future loads which may reasonably be expected within a period of 30 to 50 years, and for ultimate development of the specific drainage area concerned.

#### A. Velocity

All sanitary sewers shall be designed on a grade which produces a mean velocity, when flowing half-full or full, of no less than 2.5 feet per second. Where velocities greater than 15 fps are attained, special provisions shall be made to protect against displacement by erosion and shock. The minimum grades for the various sizes of pipe are as follows.

| Inside Pipe Diameter (inches) | Grade (feet per 100 feet) |
|-------------------------------|---------------------------|
| 6                             | 0.77                      |
| 8                             | 0.53                      |
| 10                            | 0.39                      |
| 12                            | 0.31                      |
| 15                            | 0.23                      |
| 18                            | 0.18                      |
| 21                            | 0.15                      |
| 24                            | 0.13                      |
| 27                            | 0.11                      |
| 30                            | 0.09                      |
| 36                            | 0.07                      |

In general, slopes greater than those shown above are desirable and are particularly recommended on sewers which dead end and will not be extended so they have adequate slope to self-clean. Dead-end mains shall have a minimum of 2% slope for all diameter sewers.

**B. Manning Equation**

When calculating minimum pipe slopes and velocities, the Design Engineer shall use the Manning pipe friction formula.

**C. Pipe Coefficient**

The minimum pipe roughness coefficient for sanitary sewers shall be 0.013.

**3.0.4 Alignment and Cover**

**3.0.4.01 Right-of-Way Location**

Sanitary sewer lines shall be located in the street right-of-way, 5 feet north and west of centerline whenever possible. All changes in direction of pipe shall be made at a manhole.

Sewers shall be located in the street right-of-way. If streets have curved alignments, the center of the manhole shall not be less than 6 feet from the curb face on the outside of the curve, nor the sewer centerline less than 6 feet from the curb face on the inside of the curve.

Curved alignments will not be permitted.

**3.0.4.02 Minimum Cover**

All sanitary sewers shall be laid at a depth sufficient to drain building sewers, to protect against damage by frost or traffic, and to drain basement sewers, where practical. Sufficient depth shall mean the minimum cover from the top of the pipe to finish grade at the sewer alignment. In new residential hillside subdivisions, mainline and lateral sewers shall be placed in the street at a depth sufficient to drain building sewers on the low side of the street.

Sanitary sewers shall be constructed with 5 feet minimum cover in all parts of the public right-of-way or easement.

Where the topography is relatively flat and existing sewers are shallow (5 feet or less) the minimum cover shall be 3 feet. Where required for additional strength when cover is minimal, ductile-iron pipe or C900 PVC pipe and/or CDF backfill may be required by the District Engineer.

Deviation from the above standards will be considered on a case-by-case basis when one of the following circumstances exists.



1. Underlying rock strata—required: A request in writing to the District Engineer, together with submittal of a soils report, with a plan and profile certifying that bed rock exists 3 feet below the undisturbed ground surface at all investigated alignments.
2. A ditch or stream must be crossed—required: A plan and profile; horizontal scale 1 inches = 20 feet, vertical scale 1 inches = 2 feet.
3. Other circumstances which the installer desires to vary the standards shall be submitted as a variance.

### **3.0.4.03 Separation with Waterlines**

Water mains shall be installed a minimum clear distance of 5 feet horizontally from sanitary sewers and shall be installed to go over the top of such sewers with a minimum of 18 inches of clearance at intersections of these pipes (in accordance with the requirements of OAR<sup>2</sup> Public Water Systems or equivalent). Exceptions shall first be approved by the District Engineer. In all instances the distances shall be measured edge to edge. The minimum spacing between water mains and storm drains, gas lines, and other underground utilities, excepting sanitary sewers, shall be 3 feet horizontally when the standard utility location cannot be maintained.

Where water mains are being designed for installation parallel with other water mains, utility pipe, or conduit lines, the vertical location shall be 12 inches below (or in such a manner which will permit future side connections of mains, hydrants, or services) and avoid conflicts with parallel utilities without abrupt changes in vertical grade of the above mentioned main, hydrant, or service. Where crossing of utilities are required; the minimum vertical clearance shall be 6 inches.

### **3.0.4.04 Easements**

Sewers placed in easements along a property line shall have the easement centered on the property line and the sewer shall be offset 18 inches from the property lines. For sewers placed in easements located other than along a property line, the sewer shall be placed in the center of the easement. The conditions of the easement shall be such that the easement shall not be used for any purpose which would interfere with the unrestricted use for sewer main purposes. Under no circumstances shall a building, wall, fence, or permanent structure be placed over a sanitary sewer main or sewer easement without OLWS approval. This shall include overhanging structures with footings located outside the easement.

Public easements for sewers shall have a minimum width of 20 feet. In some instances, larger width easements may be required, such as excessively deep pipes or location of a building near the easement.

---

<sup>2</sup> Chapter 333, at time of adoption

Easement locations for public sewer mains serving a Planned Unit Development, apartment complex, or commercial/industrial development shall be in parking lots, private drives, or similar open areas which will permit an unobstructed vehicle access for maintenance by OLWS personnel.

All easements must be furnished to the District Engineer for review and approval prior to recording. Easements shall state that OLWS will not in any way be responsible for replacing landscaping including any shrubs or trees, fencing, or other structures or improvements such as asphalt or curbs that may exist or have been placed in the easement.

To service underserved areas, OLWS may require public utilities and/or associated easement(s) to extend to the farthest property line or the most proximate or logical property line to connect to existing, planned, or potential utility lines.

Private easements are not regulated by Oak Lodge. Though, If an easement is needed to serve a property(ies), the easement(s) shall be provided to Oak Lodge for reference prior to connection.

#### **3.0.4.05 Relation to Watercourses**

Generally, the top of all sanitary sewers entering, crossing or adjacent to streams shall be at a sufficient depth below the natural bottom of the streambed to protect the sewer line. 1 foot of cover is required where the sewer is in rock; 3 feet of cover is required in other materials. In paved channels, the top of the sewer line shall be placed at least 6 inches below rock grade of the bottom of the channel, except as provided above.

Sewers located along streams shall be located outside of the streambed and sufficiently removed therefrom to provide for future, possible stream channel widening. All manhole covers shall be watertight at or below the 100-year flood elevation.

Sewers crossing streams or drainage channels shall be designed to cross the stream as nearly perpendicular to the stream channel as possible and shall be free from change of grade. The minimum cover shall be 36 inches from the bottom of the streambed or drainage channel.

Pipe material shall be ductile iron with an 18 foot length of pipe centered on the stream or drainage channel centerline. The ductile-iron pipe shall extend to a point where a 1-to-1 slope begins at the top of the bank and slopes down from the bank away from the channel centerline and intersects the top of the pipe.

Concrete encasement will be required when the above cover requirements cannot be met. Each deviation from the above requirements will be reviewed on a case-by-case basis and submitted as a variance request.

## 3.0.5 Structures

### 3.0.5.01 Manholes

Manholes shall conform to ASTM C-478.

Manholes shall be located at all changes in slope, alignment, pipe size, and at all pipe junctions with present or future sanitary sewers.

Manhole spacing shall not be greater than 300 feet. Spacing may be increased in special circumstances with District Engineer approval and submitted as a variance.

Manholes outside of vehicle or pedestrian travel ways shall have a tamper proof lid.

Designs for manholes are shown in the OLWS standard drawings. They are suitable for most conditions.

All sanitary manholes shall be of watertight construction. If ground water or surface drainage can be expected, watertight covers shall be used.

New designs or revisions should not be shown on the construction drawings unless the standard designs are not suitable. New or revised designs may be necessary if:

- a) One or more of the sewers to be connected to the manhole is over 36 inches in diameter (smaller diameters may require a special design if the manhole is at an alignment change.)
- b) More than two sewers will be connected to the manhole.
- c) There is less than 90 degrees between the incoming and outgoing sewer.
- d) The manhole will be subject to unusual structural loads.
- e) Diversion or other flow control measures are required.

Where one or more of conditions a), b), or c) are encountered, a drawing of the manhole base should be made to determine if it is feasible to use designs shown in the standard drawings. It may be necessary to restrict the options to a specific standard drawing specified by a note on the construction drawings. If a special design is required for any reason, it will be necessary to show the details on the construction drawings and to provide structural calculations as needed.

Some alternate manhole features are shown in the standard drawings. Where these features are required, they must be specified by a note on the construction drawings. Some examples are:

1. Slab tops must be used in lieu of cones where there will be 4 feet or less between the manhole shelf and the top of the last barrel section.

2. Watertight manhole frames and covers are to be used if floodwaters are expected to cover the manhole top or if the manhole must be located in the street gutter. Such conditions should be avoided wherever feasible.
3. Tamperproof manhole frames (7 inches depth) and covers are required in all areas outside the paved public right-of-way or pedestrian travel ways. Rims shall be 1 foot above the finished grade if not in a paved way.

Standards for elevation differences at manholes have been established to compensate for normal energy losses and to prevent surcharging of a sewer by a larger sewer. For purposes of slope calculation and for establishing elevation differences, the elevations are given at the intersection of the sewer centerlines (usually the center of the manhole). The rules for elevation differences at manholes are:

1. The crowns of incoming sewers shall be at least as high as the crown of the outgoing sewer.
2. If the incoming and outgoing sewers are of equal size and are passing straight through the manhole, no added elevation change is required.
3. If sewers intersect or the alignment changes at the manhole, the invert elevation difference shall be at least 0.10 feet for 0°-45° of horizontal deflection angle, and 0.20 feet for over 45° of horizontal deflection angle.
4. The slope of a sewer within a manhole shall be no less than the slope of the same sewer outside of the manhole.
5. Drop connections are required when the vertical distance between flow lines exceeds 2 feet. The diameter of the drop connection must be specified on the construction drawings. The diameter of the drop connection shall be the same size as the diameter of the incoming sewer. Outside drop assemblies only, will be permitted, see the standard drawings.
6. All connections must enter the manhole through a channel in the base. This includes drop connections and connections to existing manholes.

Where conditions make compliance with these rules impractical, exceptions will be permitted. It will be necessary, however, for the Design Engineer to provide a complete analysis of the need for such designs.

#### **3.0.5.02 Cleanouts**

Cleanouts will not be approved as substitutes for manholes on public sewer lines.

### **3.0.6 Laterals**

Laterals are those sewer lines which connect buildings to the sewer mains. They are comprised of the privately-owned part of the lateral located on private property, and the OLWS-owned part of the lateral located in the road right-of-way or OLWS easement.

Each individual taxlot shall be connected by a separate, lateral connected to the sewer main. Exceptions to this standard shall be applied for as a variance request and approved by the District Engineer or designee.

If a structure is replaced or reconstructed, a new sewer lateral and cleanout is required to be constructed. The replacement lateral shall adhere to current OLWS standards.

When a new lateral pipe and cleanout is required to be installed. OLWS will evaluate the tap to determine whether it can be reused for the new lateral. If the existing lateral alignment is re-used, new materials shall be installed. If a different alignment or tap location is required, the exiting sewer in the public ROW or easement shall be abandoned and disconnected at the main. If there are multiple existing laterals (in use or existing) all unused laterals shall be disconnected at the main.

Where the invert of the lateral entering a manhole is less than two feet above the manhole invert, a formed channel will be constructed utilizing Portland Cement concrete. The sewage entering the manhole will follow a smooth concrete channel transitioning evenly from the invert of the inlet pipe into the main channel. Sewage will not be allowed to fall freely to the manhole base.

The minimum inside diameter of an OLWS-owned lateral shall be 4 inches for single family residences and for multifamily complexes of three Equivalent Dwelling Units or less.

A 6-inch diameter OLWS-owned lateral is required for any commercial properties. During any commercial redevelopment, the sewer lateral(s) shall be inspected by OLWS to determine if it/they meets current material, slope and condition standards, If so, the lateral could remain. A cleanout may be required to be retrofitted to the existing lateral.

A 6-inch diameter OLWS-owned lateral is required for any residential properties or complexes of four Equivalent Dwelling Units or more.

An 8-inch diameter OLWS-owned lateral is required for properties with an 8-inch-diameter privately-owned lateral and must have a manhole installed at the property owner's cost at the point of connection to the main line. Laterals shall be built to the same construction standards and of the same materials as the sewer mainline. Laterals shall be placed at 90° to the main sewer line to avoid excessive exposure to other utilities during excavation for construction or maintenance of the laterals. Other angles may be approved for atypical conditions on a case-by-case basis and submitted as an alternate request described in Section 1. Lateral connections may be made at manholes 90° to sewer mainline if such placement would not interfere with other present or future connections to the manhole. Laterals will run straight from the tap to the clean out, with no bends and no intentional flexing of the pipe. Manhole taps are allowed when no other alternative exists. All manhole taps are to be requested with a variance application.

The minimum slope of sewer service lines shall be 2% (¼-inch-per-foot), except for unusual conditions, when a slope of 1% (⅛-inch-per-foot) may be approved. It will be necessary,

however, for the Design Engineer to provide a complete analysis of the need for any sewer service lateral slope less than 2%. The maximum slope shall be 100% (45° or 1-foot-per-foot).

Laterals shall be installed with a clean out located at the edge of the road right-of-way or at the edge of an OLWS easement. If a Public Utility Easement (PUE) is present, the clean out must still be located in the road right-of-way, not in or behind the PUE. A 4-inch lateral must have a 4-inch clean out and a 6-inch lateral must have a 6-inch clean out. The clean out riser shall extend to 6 inches below final grade, be easily accessible, have a threaded plug, and be contained within a traffic-rated protective box set to final grade. A watertight plug shall be installed in the end of the lateral and a 2x4 wood marker shall be placed at the lateral end from pipe invert to at least 36 inches above the finish grade. The marker top shall be painted green and marked with the depth of the lateral measured from ground to invert of pipe.

Laterals shall maintain or be constructed to have a minimum of two feet separation as measured by the exterior of each pipe (“skin-to-skin”). Any proposed sewer tap shall be a minimum of two feet from any other tap on the receiving line.

Laterals shall be placed at 90° to the main sewer line to avoid excessive exposure to other utilities during excavation for construction or maintenance of the laterals. Other angles may be approved for atypical conditions on a case-by-case basis and submitted as an alternate request described in Section 1. In lieu of a wye, a sewer main line extension may be required at the sole discretion of OLWS.

### **3.0.7 Connection to Existing Sewer**

Connections to, and extensions of, existing sewers will occur to facilitate new development. Certain requirements will be placed on the Design Engineer as to permitted methods and/or locations.

Connections to existing manholes shall be made with the following guidelines:

1. Where the invert of the connecting pipe is more than 2 feet above the manhole shelf, the Contractor will be required to construct an outside drop with the inlet pipe invert being located at the manhole shelf. The sewage entering the manhole will follow a smooth concrete channel transition from the inlet pipe into the main channel.
2. Where the invert is required to enter below the shelf of the manhole, the inlet pipe will not enter below a point where the crown of the new inlet pipe is below the crown of the outlet pipe. The base of the manhole will be rebuilt if damaged in this process. The sewage will enter the main flow in a smooth channel transitioning from the inlet pipe to the main channel.
3. No pipe will enter an existing manhole where the angle between the incoming flow and the outgoing flow is greater than 90°.

New laterals shall be connected by core drilling a hole in the existing main line and installing an Inserta Tee (or equivalent) per the manufacturer’s instructions.

In the case where the new lateral diameter is only 2 inches smaller than the existing main diameter (for example, 4-inch tap on a 6-inch main or a 6-inch tap on an 8-inch main), a section of main line shall be removed and a PVC tee shall be spliced in with Fernco Strongback (or equivalent) couplers. After this type of tap is bedded and trench compaction is completed, the main line will be TV inspected at the Contractor's expense to show that the new PVC tee is properly aligned with the existing main line.

If an 8-inch lateral is to be connected to an 8-inch existing main line, then a manhole shall be required at the point of connection.

New and reconstructed light rail and freight rail construction may require improvements to the existing sanitary sewer system at utility crossing locations. All existing asbestos-cement pipes or pipes on the second half of useful life within the rail zones must be replaced to current standards. Existing metallic or conductive pipe materials are not approved pipe materials at rail crossings and must be replaced to current standards.

## **3.1 SEWAGE PUMP STATION DESIGN STANDARDS**

---

### **3.1.1 General**

The pump station shall be a submersible pump type facility.

Station shall include: submersible pumps, wet well, valve vault, associated piping and valves, electrical controls, instrumentation, telemetry, access road, fencing, landscaping, and potable water supply, and shall generally conform to OLWS rules, regulations and standards.

Pump station shall be designed to pump the peak wastewater flow from the service area. When the service area is not built out, staging of pump station capacity will be allowed.

Where the flow is substantial or where environmental damage may occur due to power failure, District Engineer may require permanent standby power.

Wet well-mounted or wet well/dry well stations will not be allowed.

### **3.1.2 Design**

Pump station shall be designed to meet the minimum requirements and guidelines standards of the Department of Environmental Quality (DEQ),<sup>3</sup> regulations.

Design shall be by registered engineer experienced in design of such facilities.

Service area, peak flow, and pump station calculations shall be submitted to the District Engineer.

Wet well shall be designed to provide 4 hours of storage above high water alarm.

---

<sup>3</sup> OAR Chapter 340, Division 52 at time of adoption

### **3.1.3 Materials**

#### **3.1.3.01 Pumps**

A minimum of 2 pumps shall be supplied. Each pump shall be capable of pumping the peak wastewater flow. Where more than 2 pumps are used, the station shall be able to pump peak wastewater flow when the largest pump is out of service.

Pumps shall be submersible pumps manufactured by Hydronix (or equal), explosion-proof, suitable for hazardous location, and shall be UL or FM listed.

#### **3.1.3.02 Piping and Valves**

Piping and fittings shall be ductile iron.

Valves shall be metal, suitable for wastewater use. Valves shall be designed for wastewater service.

Provide pressure gauges on pump discharge piping.

#### **3.1.3.03 Electrical**

Electrical controls shall be located above ground mounted in a waterproof enclosure. Electrical panels shall be UL listed. The pump station wet well shall be considered a hazardous location.

#### **3.1.3.04 Controls**

Controls may be mechanical relays or programmable logic controllers.

Pumps shall alternate lead-lag position with each pumping cycle.

Bubbler shall control pump start/stop.

Float activated alarm shall indicate high water level.

An auxiliary power connector and manual transfer switch shall be provided.

#### **3.1.3.05 Alarms and Telemetry**

Alarms shall be telemetered to the OLWS SCADA system.

Alarms include:

- Pump failure
- Power failure
- Telemetry failure
- High water level
- Bypass



### **3.1.3.06 Landscaping and Fencing**

A 6-foot chain link fence with 3 strands of barbed wire and redwood slats shall surround the pump station. Access for easy maintenance shall be incorporated in the design.

### **3.1.3.07 Additional Features**

Provide 1-inch hose bib at valve vault. Potable water shall be provided by reduced pressure backflow preventer.

Provide positive ventilation in valve vault.

Odor control as required.

### **3.1.3.08 Force Main**

Force main shall be designed for a nominal flow velocity in the range of 3 to 5 feet per second.

## **3.1.4 Construction**

### **3.1.4.01 Design Codes**

Pump station and related facilities will be constructed to Electrical and Building Codes.

### **3.1.4.02 Steel Fabrications**

Steel fabrications shall be hot dipped galvanized; painting required on valves, piping, and pipe fittings.

### **3.1.4.03 Operating and Maintenance Data**

Compile product data and related information appropriate for OLWS maintenance and operation of products furnished under the Contract.

Prepare operating and maintenance manual.

Instruct OLWS personnel in the maintenance of products and in the operation of equipment and systems.

### **3.1.4.04 Spare Parts**

Supply two (2) sets each of all gaskets, bearings, and mechanical seals for rotating equipment.

## **3.2 SANITARY SEWER CONSTRUCTION**

---

### **3.2.1 Pipe and Fittings**

#### **3.2.1.01 DESCRIPTION**

This section covers the following work: (1) gravity and pressure sewer mains, (2) fittings, and (3) laterals and cleanouts and manholes and pump stations.

### **3.2.1.02 MATERIALS**

#### **3.2.1.02.01 General**

Use all sewer pipe and fittings of the size, strength, material and joint type specified on the drawings and/or the proposal. Use jointing material as hereinafter specified for each pipe material. Each piece of pipe shall be clearly identified as to strength, class and date of manufacture. The manufacturer or fabricator shall furnish appropriate certification, based on manufacturers' routine quality control tests, that the materials in the pipe and fittings meet the requirements specified herein. Strength, permeability, hydrostatic tests, and pipe joints will be used as the basis of acceptance as described under proof tests herein.

It is not intended that materials listed herein are to be considered equal or generally inter-changeable for all applications. The Design Engineer shall determine the materials suitable for the project and so specify.

#### **3.2.1.02.02 Ductile-Iron Pipe**

Ductile-iron pipe centrifugally cast of 60-42-10 iron shall conform to ANSI A21.51 Class 150 or AWWA C151, with Push-on Joint or Mechanical Joints as specified, conforming to ANSI Specification A21.11/AWWA C111. Ductile-iron pipe shall be lined with cement mortar and seal coated in accordance with ANSI Standard A21.4/AWWA C104.

When specified, tube type polyethylene encasement shall conform to ANSI A21.5/AWWA C105.

#### **3.2.1.02.03 PVC Nonpressure Pipe**

PVC sewer pipe shall conform to ASTM D 3034 SDR 35 or C900.

#### **3.2.1.02.04 HDPE Pipe**

HDPE pipe sizing shall conform with ASTM F714 or D3035. HDPE pipe material shall conform to ASTM D 3350. Pipe size and pipe dimension ratio shall be specified in the plans.

#### **3.2.1.02.05 Lateral Markers**

A 2-inch-x-4-inch stake painted green shall extend from the lateral end to a minimum of 3 feet above the ground.

#### **3.2.1.02.06 Jointing Materials**

Only lubricants for jointing materials approved by the manufacturer shall be used.

Furnish in duplicate a certified statement from the manufacturer of the gaskets, setting forth the basic polymer used in the gaskets and results of the tests of the physical properties of the compound. Gaskets shall be shipped in containers with identification of the batch from which the gaskets were fabricated.

**A. Ductile-Iron Pipe**

Rubber gaskets shall conform to ANSI A21.11/AWWA C111.

**B. PVC Pipe**

Rubber gaskets for PVC pipe shall conform to ASTM F 477. Solvent weld (glued) joints will not be allowed.

**C. HDPE Pipe**

HDPE pipe shall be joined via butt fusion welds in accordance with ASTM F 2620. The technician performing butt fusion welds shall be certified by the manufacturer or other certifying agency. Alternately, electrofusion polyethylene fittings may be used.

**3.2.1.02.07 Proof Tests**

The intent of this requirement is to prequalify a joint system, components of which meet the joint requirements, as to the water tightness capability of that joint system. This proof test shall be understood to apply to all sanitary sewers. Material and test equipment for proof testing shall be provided by the manufacturer. Joints shall meet the requirements of yard testing specified below. The pipe manufacturer shall submit results of the yard tests made, certified by a testing agency acceptable to the District Engineer. In general, each pipe material and joint assembly shall be subject to the following three proof tests at the discretion of the District Engineer.

**1. Pipe in Straight Alignment**

No more than 5 pipes selected from stock by the District Engineer or the testing agency shall be assembled according to the manufacturer’s installation instructions with the ends suitable plugged and restrained against internal pressure. The pipe shall be subjected to 13-PSI hydrostatic pressure for 10 minutes. Free movement of water through the pipe joint or pipe shall be grounds for rejection of the pipe.

**2. Pipe in Maximum Deflected Position**

A test section shall be deflected as described hereinafter for each pipe material. The pipe shall be subjected to 10-PSI hydrostatic pressure for 10 minutes. Free movement of water through the pipe joint or pipe wall shall be grounds for rejection of the pipe.

**3. Joints Under Differential Load**

The test section shall be supported on blocks or otherwise as described hereinafter for each pipe material. There shall be no visible leakage when the stressed joint is subjected to 10-PSI internal hydrostatic pressure for 10 minutes.

**A. Ductile-Iron Pipe**

For deflected position, create a position ½-inch wider than the fully compressed section on 1 side of the outside perimeter.

For differential load, support so that one of the pipes is suspended freely between an adjacent pipe, load bearing only on the joints. Apply a force per the following table along a longitudinal distance of 12 inches, immediately adjacent to 1 of the joints.

| PIPE SIZE | FORCE - POUNDS | PIPE SIZE | FORCE - POUNDS |
|-----------|----------------|-----------|----------------|
| 4 inches  | 1,000          | 15 inches | 3,700          |
| 6 inches  | 1,500          | 18 inches | 4,400          |
| 8 inches  | 2,000          | 21 inches | 5,000          |
| 10 inches | 2,500          | 24 inches | 5,500          |
| 12 inches | 3,000          | and over  | ----           |

**B. PVC Pipe**

PVC pipe joints shall be tested by and meet the requirement of ASTM C 3212 for gravity sewers and ASTM D 3139 for pressure sewers.

**3.2.1.02.08 Fittings**

Provide tee fittings in the sewer main for lateral connections. Tees for laterals shall be 4 inches inside diameter, unless otherwise specified. All fittings shall be of sufficient strength to withstand all handling and load stresses encountered. All fittings shall be of the same materials as the pipe unless otherwise specified. Material joining the fittings to the pipe shall be free from cracks and shall adhere tightly to each joining surface. Use the same type of joints on all fittings that are used on the main sewer pipe. Tee fittings shall not be closer than 12 inches to any joint or bell of main line sewer which is 12 inches or less in diameter.

**A. Ductile-Iron Pipe**

Use mechanical joint cast-iron fittings conforming to ANSI A21.10/AWWA C110, and a class of at least equal to that of the adjacent pipe. Use push-on fittings of gray cast iron with body thickness and radii of curvature conforming to ANSI A21.10 and joints conforming to ANSI A21.11/AWWA C111.

**B. PVC Pipe**

PVC pipe shall be connected to sanitary manholes only thru formed or cored holes using an approved boot type adapter specifically manufactured for the intended service and approved by the District Engineer, such as Kor-N-Seal

boots or equivalent. Sanded collars will be accepted only in poured-in-place manhole bases.

**C. HDPE Pipe**

Polyethylene fittings shall be manufactured in accordance with ASTM D 3261 for molded polyethylene fittings and ASTM F 1055 for electrofusion polyethylene fittings.

**3.2.1.02.09 Pipe Coupling Adapters**

**A. PVC Pipe, and Ductile-Iron Pipe**

Use flexible mechanical compression joint coupling with stainless steel shear proof bands such as a Fernco Strongback or approved equal.

**B. HDPE Pipe**

Electrofusion couplers shall be used to join pipe between manholes. Electrofusion couplers shall conform to ASTM F 1055.

**3.2.1.03 Construction**

**3.2.1.03.01 Excavation and Backfill**

Conform to the requirements of Standard Drawing 302 for pipe bedding and Section 1 for public easements. All excavation shall be unclassified. Clackamas County public road standards supersede OLWS standards outside of pipe zone. All mains, manholes, taps, laterals, and clean outs must be inspected by an OLWS representative before burial. Any installations backfilled prior to inspection must be excavated for OLWS inspection at the contractor's expense.

**3.2.1.03.02 Line and Grade for Gravity and Pressure Sewers**

Do not deviate from line or grade, as established by the Design Engineer, more than ½ inch for line and ¼ inch for grade, provided that such variation does not result in a level or reverse sloping invert. Flat grade, negative slope, "bellies", or "sags" will not be accepted. Measure for grade at the pipe invert, not at the top of the pipe, because of permissible variation in pipe wall thickness. Establish line and grade for pipe by the use of lasers or by transferring the cut from the offset stakes to batter boards at maximum intervals of 25 feet.

**A. Line and Grade for Laterals**

The Design Engineer will establish line and grade to the tract of land to be serviced by the sewer system. At the preselected location of a lateral a stake will be driven into the ground showing the depth of excavation required at the property line.

The lateral must be laid perpendicular to the main whenever possible. Lay the pipe on a straight line and at a minimum of 2% grade between the tee and the clean out. The lateral shall be installed with the same accuracy as the main sewer and shall be a minimum of 5 feet of cover in all parts of the road right of way or easement.

### **3.2.1.03.03 Pipe Distribution and Handling**

Distribute material on the job no faster than it can be used to good advantage. Unload pipe only by means recommended by the pipe manufacturer. Do not unload pipe of any size by dropping to the ground. Do not distribute more than 1 week's supply of material in advance of laying, unless approved.

Pipe shall not be unloaded or stored in the public right-of-way or easement unless it has been certified and accepted by the Design Engineer. Inspect all pipe and fittings prior to lowering into trench to ensure no cracked, broken, or otherwise defective materials are used. Clean ends of pipe thoroughly. Remove foreign matter and dirt from inside of pipe and keep clean during and after laying.

Use proper implements, tools, and facilities for the safe and proper protection of the work. Lower pipe into the trench in such a manner as to avoid any physical damage to the pipe. Remove all damaged pipe from the job site, Do not drop or dump pipe into trenches.

### **3.2.1.03.04 Pipe Laying and Jointing of Pipe and Fittings**

#### **A. General**

Proceed with pipe laying upgrade with spigot ends pointing in direction of flow. Place pipe in such a manner as to ensure a continuous and uniform bearing and support for the full length of the pipe between joints. Take care to properly align the pipe before forced entirely home. Upon completion of pipe laying all pipe joints shall be in the "home" position, which is defined as the position where the least gap (if any) exists, when the pipe components that comprise the join are fitted together as tightly as the approved joint design will permit. Gaps at pipe joints shall not exceed that allowed by the manufacturer's recommendations.

Take special care to prevent movement of the pipe after installation when laid within a movable trench shield.

When laying operations are not in progress, protect the open end of the pipe from entry of foreign material and block the pipe to prevent movement or creep of gasketed joints.

Plug or close off pipes which are stubbed out for manhole construction or for connection by others.

When cutting and/or machining the pipe is necessary, use only tools and methods recommended by pipe manufacturer.

When shown or approved to deflect pipe from a straight line, either in the vertical or horizontal plane, or when long-radius curves are shown, the amount of deflection shall not exceed that specified or approved by the District Engineer. The pipe manufacturer's recommendation will serve as a guide, but the decision of the District Engineer shall be final.

The contractor shall at all times provide and maintain ample means and devices to remove and dispose of all water entering the trench excavation during the process of laying the pipe. Water and debris shall not enter into the OLWS's sewer system. Water and debris shall be disposed of in an approved manner.

#### **3.2.1.03.05 Installation of Tees and Laterals**

Provide pipe bedding material compacted to a minimum of 90% of maximum density as determined by ASTM D 1557/AASHTO T-180 under all tee fittings, extending to the springline of the fittings. Place pipe bedding material on undisturbed native material or compacted foundation stabilization material.

Use pipe and fittings for laterals of one type of material throughout; no interchanging of pipe and fittings will be allowed. Use 4-inch diameter pipe for residential laterals when not otherwise specified. Commercial and Industrial laterals must be a minimum of 6-inch diameter.

For 6-inch-x-8-inch connections, a "pipe snap cutter" shall be used to cut the main line and dress-in a factory tee.

Connect laterals to manholes only when directed. Connections to existing manholes shall be by way of a core drilled hole and use a Kor-N-Seal boot or equivalent.

Provide ends of all laterals with approved watertight plugs, or caps, suitably braced to prevent blow-off during internal air testing. Clean outs must be installed on the laterals prior to air testing.

Any new sanitary sewer tap location(s) must be a minimum distance of two (2) linear feet on either side of the main line from any other existing tap / lateral location.

All sanitary taps (both spliced-in taps and Inserta-Tee taps) will require a post-tap main line TV inspection. The inspection will be performed at the contractor's cost and after backfill and compaction is complete. Items under inspection will be excessive tap intrusion, leaks, alignment, and damage to the main line.

Permits for all sanitary installations (including single sanitary laterals for single lot development) must state that the installation is under warranty for a period of 12 months. At the end of 12 months OLWS will TV the lateral to determine if the installation is accepted or if repairs are required.

#### **3.2.1.03.06 Lateral Markers**

In new subdivisions, undeveloped areas, and where connections will not be made in the Contract, after the service line is installed, block the capped or plugged end and install 2-inch-x-4-inch marker. Extend markers at least 3 feet above the ground surface. Paint the top portion of the marker green. Write the depth of the lateral on the marker with permanent ink.

Take precautions during the backfilling operation to ensure the position and location of the marker. If the marker is broken or knocked out of vertical alignment during the backfilling operation, reopen the trench and replace the marker.

### **3.2.1.03.07 Testing**

#### **A. General**

All gravity sanitary sewers shall successfully pass an air test prior to acceptance and shall be free of leakage. Manholes shall be tested as specified in Section 3.2.2 (Manholes and Concrete Structures).

All pressure sewer force mains shall be tested in accordance with applicable portions of Section 3.1, when not otherwise specified.

Lines shall be cleaned prior to any television inspection.

A television inspection of the sanitary sewer pipe shall be performed. Any defects in material or workmanship shall be satisfactorily corrected prior to final acceptance of the work.

No private plumbing can be connected to a new sanitary system installation without OLWS approval. OLWS will not approve or accept a sanitary system installation if any private plumbing has been connected to it.

#### **B. Cleaning Prior to Testing and Acceptance**

Prior to testing and television inspection of the sewer system hydro clean all parts of the system and remove all debris.

Upon the District Engineer's final manhole-to-manhole inspection of the sewer system, if any foreign matter is still present in the system, hydroclean the system a second time as required and remove the debris.

#### **C. Testing Procedure**

Perform the tests in a manner satisfactory to the District Engineer. Calibrate gauges for air testing with a standardized test gauge provided by the Contractor at the start of each testing day. The calibration shall be witnessed by the District Engineer; notify the District Engineer 24 hours prior to each test.

#### **D. Time of Test**

Make tests of sections of constructed sanitary sewer for acceptance only after all service connections, manholes, backfilling, and compaction are completed between the stations



to be tested. OLWS may require testing of manhole-to-manhole sections as they are completed in order to expedite the acceptance of sections of sewer and allow connections prior to the whole system being completed.

## **E. Repairs**

Repair or replace, in a manner satisfactory to the District Engineer, any section of pipe not meeting the air test requirements, or which has leakage.

Infiltration of ground water in an amount greater than herein specified, following a successful air test as specified, shall be considered as evidence that the original test was in error or that subsequent failure of the pipeline has occurred. Correct such failures occurring within the warranty period in a manner satisfactory to the District Engineer at the Contractor sole expense.

The Contractor, in contracting to do this work, agrees that the leakage allowances as indicated herein are fair and practical.

## **F. Air Testing**

### **1. General**

The District Engineer may, at any time, require a calibration check of the instrumentation used. Use a pressure gauge having minimum divisions of 0.10 PSI and an accuracy of 0.0625 PSI. (1 ounce per square inch.) All air used shall pass through a single control panel.

All plugs used to close the sewer for the air test must be capable of resisting the internal pressures and must be securely braced. Place all air testing equipment above ground and allow no one to enter a manhole or trench where a plugged sewer is under pressure. Release all pressure before the plugs are removed. The testing equipment used must include a pressure release device designed to relieve pressure in the sewer under test at 10 PSI or less and must allow continuous monitoring of the test pressures in order to avoid excessive pressure. Use care to avoid the flooding of the air inlet by infiltrated ground water. (Inject the air at the upper plug if possible.) Use only qualified personnel to conduct the test.

Do not coat pipes for sewers internally or externally with any substance of any type in an attempt to improve its performance when air tested.

### **2. Ground Water**

The presence of ground water will affect the results of the test. Determine the average height of ground water over the sewer immediately before starting the test.

In every case, determine the height of the water table at the time of the test by exploratory holes or such other methods satisfactory to the District Engineer. The District Engineer will make the final decisions regarding test height for the water in the pipe section being tested.

### 3. Method

Use the Time-Pressure Drop Method for all air testing. The test procedures are described as follows:

1. Clean the sewer to be tested and remove all debris where noted.
2. Wet the sewer prior to testing, if desirable.
3. Plug all sewer outlets with suitable test plugs. Brace each plug securely.
4. Check the average height of the ground water over the sewer. The test pressures required below shall be increased 0.433 PSI for each foot of average water depth over the sewer.
5. Add air slowly to the section of sewer being tested until the internal air pressure is raised to 4.0 PSIG greater than the average back pressure of any ground water that may submerge the pipe.
6. After the internal test pressure is reached, allow at least 2 minutes for the air temperature to stabilize, adding only the amount of air required to maintain pressure.
7. After the temperature stabilization period, disconnect the air supply.
8. Determine and record the time in seconds that is required for the internal air pressure to drop from 3.5 PSIG to 2.5 PSIG greater than the average back pressure of any ground water that may submerge the pipe.

### 4. Acceptance

The sewer shall be considered acceptable when tested as described herein before if the section under test does not lose air at a rate greater than 0.0015 cfm per square foot of internal sewer surface.

For test sections containing over 625 square feet of surface area, the time measured by this method for 1.0 PSI pressure drop shall be calculated according to the following formula:

$$T = d^2L/42$$

T = test duration, seconds  
d = pipe diameter, inches  
L = section length, feet  
42 = conversion factor

For test sections containing less than 625 square feet of internal surface area, the time measured by this method for 1.0 PSI pressure drop shall be calculated according to the following formula:

$$T = 56d$$

The internal surface area of pipeline sections may be calculated using the formula:

$$A = \pi Ld/12$$

The surface areas of lateral lines of differing lengths and diameters may be accommodated in Equations 1 and 2 above by using the sums  $d_1^2L_1 + \dots + d_n^2L_n$  and  $d_1 + \dots + d_n$  in place of  $d^2L$  and  $d$ , respectively.

### **3.2.1.03.08 Deflection Test for PVC Pipe and HDPE Pipe**

In addition to air testing, perform a deflection test for all sanitary sewers constructed of PVC pipe or HDPE pipe after the trench backfill and compaction has been completed. The test shall be conducted by pulling an approved mandrel through the completed pipeline after compaction is completed. The diameter of the mandrel shall be 95% of the internal pipe diameter. Conduct testing on a manhole-to-manhole basis and only after the line has been completely flushed clean with water. Locate and repair any sections failing to pass the test and retest the section, at the Contractor's sole expense.

### **3.2.1.03.09 Subsequent Failure**

No infiltration of ground water in the system is allowed. No standing water is allowed.

### **3.2.1.03.10 Rail Lines Crossing Sanitary Sewer**

New and reconstructed light rail and freight rail construction may require improvements to the sanitary sewer system at all utility crossing locations. Each utility crossing area is to be minimized. All existing pipes on the second half of useful life within the rail zones shall be replaced to current standards. Metallic or conductive pipe materials are not approved pipe materials at rail crossings. Pipes are to be centered under rail tracks to avoid joints underneath rail lines. All new pipe installations must identify practical future replacement options for the sewer pipe under rails in case of future failure of utility.

### **3.2.1.03.11 Television Inspection of Sanitary Sewers**

Upon completion of all sewer construction, repairs, cleaning, and required tests, the Contractor shall notify the District Engineer 24 hours prior to when the television inspection will be performed.

Subsequent to being notified, the District Engineer shall commence examination of lines. Findings will be recorded.

When performing television inspections, water shall be added and a one inch measuring ball shall be utilized.

Upon correction of deficiencies revealed by television inspection, the Contractor shall notify the District Engineer; the same steps listed above may be repeated until all work is acceptable.

OLWS may, at its own option, perform a deflection test.

## **3.2.2 Manholes and Concrete Structures**

### **3.2.2.01 Description**

This section covers the work necessary for the construction of the following items: (1) manholes, (2) drop assemblies, and (3) concrete encasement.

### **3.2.2.02 Materials**

#### **3.2.2.02.01 Base Rock**

$\frac{3}{4}$ -inch minus base rock, conforming to the requirements for crushed aggregate material in Detail Drawing 302.

#### **3.2.2.02.02 Forms**

Forms for exposed surfaces shall be steel or plywood. Others shall be matched boards, plywood or other approved material. Form all vertical surfaces. Trench walls, large rock, or earth shall not be used as form material.

#### **3.2.2.02.03 Concrete and Reinforced Steel**

Concrete and reinforcing steel shall conform to Section 205 (Materials—Types and Use).

#### **3.2.2.02.04 Cement Mortar**

When specified for use, cement mortar shall conform to Detail Drawing 305 for concrete equivalencies. Mortar mixed for longer than 30 minutes shall not be used.

#### **3.2.2.02.05 Manholes**

##### **A. Standard Precast Manhole Sections**

Furnish sections as specified conforming to the details on the standard drawings and to ASTM C 478. Cones shall have same wall thickness and reinforcement as manhole section. Provide eccentric cones with precast grooves for all manholes over 6 feet in depth. Flat slab tops with precast grooves reinforced to withstand AASHTO H20 loading shall be provided for manholes 4 feet deep from crown of pipe and less. Top and bottom of all sections shall be parallel.

Prior to the delivery of any size of precast manhole section on the job site, yard permeability tests will be conducted at the point of manufacture. The precast sections to be tested will be selected at random from the stockpiled material that is to be supplied for the job. All test specimens will be mat tested, and shall meet the permeability test requirements of ASTM C 14 and ASTM C 497.

##### **B. Precast Concrete Bases**

Manholes shall be constructed using precast, reinforced concrete bases. Construction of precast bases shall conform to the requirements of ASTM C478. The base riser section shall be integral with the base slab.

**C. Poured in Place Manhole Bases**

The Contractor may use poured in place manhole bases only when pouring a new base over an existing main line. Concrete shall conform to Section 3.2020 (Manholes and Concrete Structures).

**D. Manhole Grade Rings**

Concrete grade rings for extensions shall be a maximum of 6 inches high.

**E. Jointing Materials**

Preformed plastic gaskets conforming to the requirements of AASHTO M-198 or joints using confined O-ring with rubber gaskets conforming to ASTM C443 shall be used.

**3.2.2.02.06 Pipe and Fittings**

Conform to requirements of Section 3.

**3.2.2.02.07 Manhole Frames and Covers**

**A. General**

1. All castings shall be true to size, weight and tolerances shown on the standard drawings. Delivered weight shall be +/- 5% of the specified weight. The bearing seat shall not rock when checked by the test jig. The foundry shall supply all test gauges and shall not subcontract any of the work other than testing procedure, patterns, and machining and cartage. The casting shall not be made by the open mold method and shall be free of porosity, shrink cavities, cold shuts, or cracks, or any defects which would impair serviceability. Repair of defects by welding, or by the use of "smooth-on" or similar material will not be permitted. All castings shall be shot or sandblasted, and the application of paint or other coating will not be permitted. Standard manhole frames are required in state, county and public road right-of-way. Suburban manhole frames are acceptable in private roads, driveways, and easements. Only 2-hole lids will be accepted. In landscaped easements MH frames must be set slightly above final grade.
2. All manhole frames and covers located outside of the right-of-way shall be tamper-proof.

**B. Materials**

Conform to ASTM A 48, Class 30B with the following revisions:

|                            |  |
|----------------------------|--|
| Tensile Strength           | 30,000 PSI                             |
| Traverse Strength:         | (1.2 inch diam. bar - 18 inch centers) |
| Load - Pounds              | 2,600 - 3,000                          |
| Deflection - Inches        | 0.22 - 0.34                            |
| Brinell Hardness (as cast) | 173 - 200                              |

The foundry shall certify as to the tensile and traverse properties and the Brinell Hardness. OLWS reserves the right to require a Rough Transverse bar (size of bar 1.2 inch diam. by 20 inch long) and/or a tensile bar as per ASTM A 48 for each 20 castings or heat when less than 20 castings are made.

**C. Inspection**

Notify OLWS at least 24 hours in advance of casting the units or bars. At least 24 hours notice shall also be given prior to final gauging and inspection. When directed, the following strength test shall be made on the manhole cover. The cover, while resting in its frame, shall sustain a concentrated load of 40,000 lbs. applied at its center through a 2½-inch plug. The District Engineer may, at any time, require up to 5% of the job and/or order to be tested in this manner. In case of failure during the test, additional covers shall be furnished until the tests prove satisfactory. Covers that do not pass this test shall not be used.

**D. Cap Screws**

Cap screws and washers for tamperproof and watertight manhole covers shall be stainless steel with 60,000 PSI minimum tensile strength conforming to ASTM A 453.

**3.2.2.02.08 Steps for Precast Manholes**

Steps for precast manholes shall be of ¾-inch diameter structural steel in conformance with the standard details or be of steel reinforced polypropylene plastic, M.A. Industries, Inc., No PS-2PFS, or Lane No. P-13850, or approved equal. All steps shall be in conformance with ASTM C-478 and shall be aligned vertically. All steps within a manhole shall be of the same design, type and size (mixing of unmatched steps within the same manhole is not permitted). Loose steps shall be cause for rejection of that manhole cone or section.

Steps of ¾-inch diameter structural steel shall conform to ASTM A 36 and galvanized in accordance to ASTM A 123. Steps shall be safety type 12-inch-x-8-inch-x-2-inch pattern as shown on the standard plans.

Steel reinforced polypropylene steps are to be driven into pre-formed holes in precast concrete manhole cones and sections by the manhole manufacturer prior to delivery to job site and shall be in conformance with the following specifications:

- ASTM A-615 Grade 60, ½ inch deformed steel rod
- ASTM 2146-78 Type II, Polypropylene

**3.2.2.02.09 Nonshrink Grout**

Nonshrink grout shall be Sika 212, Euco N-S, Five-Star, or equal nonmetallic cementitious commercial grout exhibiting zero shrinkage per ASTM C-827 and CRD-C-621. Grout shall not be amended with cement or sand, and shall not be

reconditioned with water after initial mixing. Unused grout shall be discarded after 20 minutes and shall not be used.

Nonshrink grouts shall be placed or packed only with the use of an approved commercial concrete bonding agent applied to all cured concrete surfaces being grouted. The bonding agent shall be compatible with the brand of grout being used. Water as a substitute for commercial bonding agent for nonshrink grout will not be allowed in sanitary sewer construction.

### **3.2.2.03 Construction**

#### **3.2.2.03.01 General**

##### **A. Excavation and Backfill**

Conform to applicable provisions in Section 3.2.1 (Excavation, Embankment, Bedding, and Backfill). Backfill around manholes shall be of the same quality as the trench backfill immediately adjacent. All excavation shall be unclassified. All mains, manholes, taps, laterals, and clean outs must be inspected by an OLWS representative before burial. Any installations backfilled prior to inspection must be excavated for OLWS inspection at the contractor's expense.

##### **B. Base Rock**

Place crushed aggregate base rock and thoroughly compact with a mechanical vibrating or power tamper.

##### **C. Foundation Stabilization**

If material in bottom of excavation is unsuitable for supporting manholes and other sewer appurtenances, excavate below subgrade as directed and backfill to required grade with rock conforming to Foundation Stabilization in Detail Drawing 304.

#### **3.2.2.03.02 Manholes**

All manholes, except as otherwise specified, shall be constructed using precast, reinforced concrete base sections, riser sections, and other precast appurtenances conforming to ASTM C478. Base riser sections shall be integral with the base slabs.

Preformed plastic gaskets shall be installed in strict accordance with the manufacturer's recommendation. Only pipe primer furnished by the gasket manufacturer will be approved. When using preformed plastic gaskets, manhole sections with chips or cracks in the joint surfaces shall not be used. Completed manholes shall be rigid and all manholes for sanitary sewers shall pass the vacuum test. Construct manhole inverts in conformance with the standard drawings with smooth transitions to ensure an unobstructed flow through manhole. Cover exposed edges of pipe completely with grout. Trowel all grouted surfaces smooth.

The inside of all manholes will be grouted smooth with all spaces between risers, rings, and cones filled with grout flush with the inside of the manhole.

Holes for installing pipe into precast manhole sections shall be cast in place or core drilled.

Channels shall conform accurately to sewer grade. Channel shall be formed to accept a 7-inch x 30-inch cylinder into the pipes. Construct cast in place channel and shelf, in field, in 1 operation. Finish concrete shelf between channels with a brush.

#### **3.2.2.03.03 Drop Assemblies**

Construct drop assemblies at locations indicated and as shown on the standard drawings.

#### **3.2.2.03.04 Pipe Stubouts and Manholes**

Install stubouts from manholes at locations as shown or directed. Pipe connections to the cone section of a manhole are strictly prohibited.

#### **3.2.2.03.05 Manhole Grade Rings**

In general, manhole grade rings will be used on all manholes in streets or roads or other locations where a subsequent change in existing grade may take place. Extensions will be limited to a maximum height of 12 inches.

Install appropriate combination of grade rings to a height that will accommodate the finish manhole surface elevation as shown on the drawings. Lay grade rings in mortar with sides plumb and tops level. All mortared sanitary sewer manhole necks and all grade ring joints made with mortar shall be constructed using an approved commercial concrete bonding agent applied to all cured concrete surfaces being mortared. No joints, necks, frames, or grade rings on sanitary sewers shall be mortared without an approved bonding agent. Water as a substitute for commercial concrete bonding agent will not be approved. Grade ring extensions shall be watertight.

#### **3.2.2.03.06 Adjustment of Manholes and Cleanouts to Grade**

The frame and cover will be adjusted to final grade after the first lift of AC has been placed and prior to the final lift. The void between the frame and the first lift of AC will be filled with Type B grout conforming to Section 3.02 (Materials—Types and Use). The manhole frame must be flush with the final grade of the roadway without the use of paving rings.

#### **3.2.2.03.07 Vacuum Testing**

Manholes shall be vacuum tested.

For manholes with poured bases constructed over existing main lines, the top of the existing main shall not be “cut out” until the manhole vacuum test has been witnessed and approved by an OLWS inspector.



1. Each manhole may be tested immediately after assembly and prior to backfilling for Contractor information and ease of repair if necessary. Acceptance testing will be accomplished after backfilling and final paving is complete.
2. All lift holes shall be plugged with an approved nonshrink grout. Manhole frame to grade ring or cone connection shall use commercial concrete bonding agent and nonshrink grout.
3. All pipes entering the manhole shall be plugged, taking care to securely brace the plug from being drawn into the manhole.
4. The test head shall be placed at the inside of the top of the manhole frame and the seal inflated in accordance with the manufacturer's recommendations. The seal at grade rings and frame shall be subject to the test.
5. A vacuum of 10 inches of mercury shall be drawn and the vacuum pump shut off. With valves closed, the time shall be measured for the vacuum to drop to 9 inches. The manhole shall pass if the time for the vacuum reading to drop from 10 inches of mercury to 9 inches of mercury meets or exceeds the values indicated below.

| DEPTH OF MANHOLE (FEET) | ALLOWABLE TIME (SECONDS) |         |         |
|-------------------------|--------------------------|---------|---------|
|                         | 48-INCH                  | 60-INCH | 72-INCH |
| 8                       | 20                       | 23      | 33      |
| 10                      | 25                       | 33      | 41      |
| 12                      | 30                       | 39      | 49      |
| 14                      | 35                       | 46      | 57      |
| 16                      | 40                       | 52      | 67      |
| 18                      | 45                       | 59      | 73      |
| 20                      | 50                       | 65      | 81      |
| 22                      | 55                       | 72      | 89      |
| 24                      | 59                       | 78      | 97      |
| 26                      | 64                       | 85      | 105     |
| 28                      | 69                       | 91      | 113     |
| 30                      | 74                       | 98      | 121     |

6. If the manhole fails the initial test, necessary repairs shall be made with an approved nonshrink, quick-setting grout. Retesting shall proceed until a satisfactory test is obtained.

### 3.2.2.03.08 Placing Precast Units

If material in bottom of trench is unsuitable for supporting unit, excavate as directed and backfill to required grade with foundation stabilization material in conformance with Section 3.2.1 (Excavation, Embankment, Bedding, and Backfill). Set units to grade at locations shown or directed.

#### **3.2.2.03.09 Cleaning**

Upon completion, clean each structure of all silt, debris, and foreign matter.

### **3.2.3 Work on Existing Sanitary Sewers**

#### **3.2.3.01 Description**

This section covers the work necessary to join new work to existing, the abandoning of sanitary sewer lines, and adjusting existing utility structures to finished grades.

#### **3.2.3.02 Materials**

Conform to requirements of Section 3.02 (Materials—Types And Use) and to the requirements for related work referred to herein.

##### **3.2.3.02.01 Inside Drops (Oregon Drops)**

This type of connection will only be allowed with prior approval by the District Engineer and shall conform to the requirements of the standard drawing.

#### **3.2.3.03 Construction**

##### **3.2.3.03.01 Excavation and Backfill**

Conform to requirements of Section 3.2.1 (Excavation, Embankment, Bedding, and Backfill). All excavation shall be unclassified. All mains, manholes, taps, laterals, and clean outs must be inspected by an OLWS representative before burial. Any installations backfilled prior to inspection must be excavated for OLWS inspection at the Contractor's expense.

##### **3.2.3.03.02 Manholes Over Existing Sewers**

The Contractor shall be totally responsible for maintaining adequate capacity for flow at all times and adequately protecting new and existing work.

Construct manholes over existing operating sewer lines at locations shown. Perform necessary excavation and construct new manholes in conformance with applicable requirements of Section 3.2.2 (Manholes and Concrete Structures).

Construct manholes as shown on the detail drawings or standard drawings. Densify the concrete base by vibrating or working as approved and screed to provide a level, uniform bearing for precast sections.

Place the first precast section of manhole in concrete base before concrete has set and deposit sufficient mortar on the base to assure a watertight seal between the base and

the manhole wall. First section shall be properly located and plumb. Stacking additional precast manhole sections shall be prohibited until the concrete has cured a sufficient amount to support the additional weight in moist conditions.

Prevent broken material or debris from entering sewer flow. Maintain flow through approved sewer lines at all times. Protect new concrete and mortar for a period of 7 days after placing. All sanitary sewer manholes shall be vacuum tested in accordance with Section 3.2237 (Vacuum Testing).

### **3.2.3.03.03 Connection to Existing Main**

Connections of laterals to existing sewer mains shall be made watertight. Transition couplings between dissimilar pipe materials shall be made using approved commercial adapters with stainless steel bands such as Fernco Strongbacks or equal.

New taps made to existing main lines shall be made by installation of an Inserta Tee or equal unless the tap diameter is within 2 inches of the main diameter (such as a 4-inch on 6-inch tap or a 6-inch on 8-inch tap). In those cases, a section of main line must be cut out and a PVC tee fitting spliced into the main with Fernco Strongbacks or equivalent. The Contractor shall be totally responsible for maintaining adequate capacity for flow at all times and for containing all wastewater within the system at all times. A written plan for pump-around or containment of sewage must be approved by OLWS before work may begin. Special care must be taken to compact bedding material under the new tap to provide proper support of the main. The Contractor must TV inspect the new tap section of main after backfilling and compaction is completed to confirm that the new Inserta Tee does not protrude into the main excessively or to confirm that the new tap section of the main is properly aligned with the existing main at both ends. This TV inspection is to take place with an OLWS inspector present.

Taps shall be installed without protrusion into or damage to the existing sewer. No compromise of the sewer will be allowed, such as undermining and settlement of the sewer grade, debris in the sewer, or longitudinal or transverse cracking of the sewer pipe.

### **3.2.3.03.04 Removal of Existing Pipes, Manholes, and Appurtenances**

Existing pipelines, manholes, and appurtenances which lie in the line of and are to be replaced by the new construction shall be removed from the site and disposed of as provided for in Section 2.8.2.03 (Clearing and Grubbing).

### **3.2.3.03.05 Filling Abandoned Manholes**

Existing manholes shown to be abandoned shall be filled with granular material as specified in Section 3.2.1 (Excavation, Embankment, Bedding, and Backfill). Compact to at least 90% maximum density as determined by ASTM D1557. Remove manhole frame and cover and plug all pipes with permanent plugs as specified in Section 3.2.3.03.07 (Permanent Plugs). Break or perforate the bottom to prevent the entrapment of water.

### **3.2.3.03.06 Existing Manhole Frames and Covers**

Manhole frames and covers removed by the Contractor which will not be reused on the project shall become the property of OLWS. Notify the District Engineer a minimum of 1 day prior to removal to arrange for picking up the removed frames and covers.

### **3.2.3.03.07 Permanent Plugs**

Clean interior contact surfaces of all pipes to be cut off or abandoned. For pipe 12 inches or smaller in diameter, install a gripper-type mechanical plug into the main and grout over it. For pipe 21 inches and larger, the plugs may be constructed of common brick or concrete block. Plaster the exposed face of block or brick plugs with mortar. All plugs shall be watertight and capable of withstanding all internal and external pressures without leakage.

### **3.2.3.03.08 Adjusting Existing Structures to Grade**

Existing manholes, and similar structures shall be brought to the specified finished grade by methods of construction, as required in Section 3.2.3.03.08 (Adjustment of Existing Structures to Grade).

### **3.2.3.03.09 Reconstruct Manhole Base**

Conform to applicable requirements of Section 3.2.2 (Manholes and Concrete Structures). Exercise caution in chipping out existing concrete base so as to prevent cracking of manhole walls. Prevent all material from entering the sewer flow. Pour new base to a minimum of 6 inches below the lowest projection of the pipe. Construct new channels to the elevations shown. Conform to details for channel construction in the standard drawings. Repair any cracks which occur as a result of work operations with new grout to form a watertight seal.

### **3.2.3.03.10 Manhole Required**

If a connection is to be an 8-inch tap on the same size receiving line, then a manhole shall be required to make the connection.

### **3.2.3.03.11 Connection to Existing Manholes**

All sanitary sewer pipe connections, including those at invert level and penetrations for drop connectors, conduits, and pass-throughs, shall conform to the requirements of applicable portions of Sections 3.2.1 (Pipe and Fittings) and 3.2.2 (Manholes and Concrete Structures).

## **END OF SECTION**

# SECTION 4—WATER DESIGN AND CONSTRUCTION STANDARDS

## TABLE OF CONTENTS

|        |   |    |
|--------|---|----|
| 4.0    | WATER MAINS.....                                  | 1  |
| 4.0.1  | General Design Requirements .....                 | 1  |
| 4.0.2  | Alignment and Cover.....                          | 3  |
| 4.0.3  | Appurtenances.....                                | 4  |
| 4.0.4  | Backflow Prevention .....                         | 6  |
| 4.0.5  | Water Service Lines.....                          | 7  |
| 4.0.6  | System Testing .....                              | 10 |
| 4.0.7  | Water Quality Sampling Stations .....             | 10 |
| 4.0.8  | Water Service/Permit Application Meters.....      | 10 |
| 4.1    | GENERAL CONSTRUCTION .....                        | 12 |
| 4.2    | WATER WORKS MATERIALS .....                       | 13 |
| 4.2.1  | Ductile-Iron Fittings.....                        | 13 |
| 4.2.2  | Mechanical Joints.....                            | 13 |
| 4.2.3  | Flanged Joints.....                               | 13 |
| 4.2.4  | Flanged Pipe or Spools .....                      | 14 |
| 4.2.5  | Ductile-Iron Pipe .....                           | 14 |
| 4.2.6  | Valves (General) .....                            | 14 |
| 4.2.7  | Fire Hydrant Assembly .....                       | 15 |
| 4.2.8  | Cast-Iron Valve Boxes.....                        | 15 |
| 4.2.9  | 2-inch Service Saddles.....                       | 16 |
| 4.2.10 | Copper Pipe .....                                 | 16 |
| 4.2.11 | Brass Fittings .....                              | 16 |
| 4.2.12 | Corporation Stops .....                           | 16 |
| 4.2.13 | Meter Stops.....                                  | 16 |
| 4.2.14 | Customer Side Plumbing.....                       | 16 |
| 4.2.15 | Waterline Materials at Light Rail Crossings ..... | 16 |
| 4.3    | CONSTRUCTION.....                                 | 17 |
| 4.3.1  | Storage of Equipment and Materials .....          | 17 |
| 4.3.2  | Placing Pipe and Fittings .....                   | 17 |
| 4.3.3  | Wet Tapping Existing Main .....                   | 18 |
| 4.3.4  | Polyethylene Encasement of Pipe and Fittings..... | 18 |

|        |   |    |
|--------|---|----|
| 4.3.5  | Placing Valve Units .....                     | 19 |
| 4.3.6  | Placing Fire Hydrant Assemblies .....         | 19 |
| 4.3.7  | Copper Service Installation .....             | 20 |
| 4.3.8  | Placing Permanent Blow-Off Assemblies.....    | 21 |
| 4.3.9  | Removing Existing Water Works Materials ..... | 21 |
| 4.3.10 | Abandoning Existing Mains and Valves .....    | 22 |
| 4.3.11 | Maintaining Service.....                      | 22 |
| 4.3.12 | Flushing .....                                | 22 |
| 4.3.13 | Testing and Chlorination .....                | 23 |
| 4.3.14 | Cut-In and Connection to Existing Mains.....  | 25 |
| 4.3.15 | Clay Dams.....                                | 26 |

## 4.0 WATER MAINS

---

### 4.0.1 General Design Requirements

**Performance Standards:** Water distribution systems shall be designed to meet State Water Administrative Rules, AWWA Standards, and guidelines of these Design Standards.

Water system design shall provide adequate flow for fire protection and maximum water usage and consumption. Required water system demands shall be met by maintaining the minimum operating pressures required by OLWS. For single-family residential areas, the minimum static pressure shall be 35 PSI, and the minimum fire flow shall be 1,000 GPM. For all other developments, the required fire flow shall be as determined by the Fire Marshal.

Water system design shall meet distribution needs for maximum water usage and consumption within a given pressure zone. New water systems shall allow for future extensions beyond present development.

When water systems are designed where velocities are greater than 5 fps, special provisions shall be made to protect against displacement by erosion and shock.

All waterlines shall be located within the public right-of-way or as directed by the District Engineer. These lines are placed in the public right-of-way for ease of maintenance and access, control of the facility, operation of the facility, and to permit required replacement and/or repair. The District Engineer, under special conditions, may allow a public waterline to be located within a public water easement as referenced in Subsection 4.0.2.04 (Easements).

#### 4.0.1.01 Pipe Materials and Size

All public water distribution systems shall be constructed with ductile-iron pipe. All such pipe shall be cement mortar-lined pipe with push-on or mechanical type joints. When a corrosive potential condition is encountered, all ductile-iron pipe and fittings will be polyethylene encased with an 8 mil tubing meeting manufacturer and AWWA standards. Where an active cathodic protection system is encountered as a result of other utilities, a deviation from the normal pipe design/material/installation practice may be required by the District Engineer.

All pipe, valves and fittings shall be pressure rated for 250 or 350 PSI. All fittings shall be factory cement lined and coated.

Water distribution main sizes shall generally conform to the following:

All new water mains must be 8-inch or greater unless otherwise approved by District Engineer for special cases including dead-end mains beyond the hydrant where no expansion is anticipated or likely and generally less than 250 feet in length. Any main less than 8 inches shall terminate with a standard blowoff per standard drawing 413. Fire hydrants are not permitted on lines less than 8 inches.

**8-inch diameter pipe is the minimum size for primary feeder mains in residential subdivisions and general system. The minimum size distribution water main for**

the grid (looped) system, not to exceed an unsupported length of 600 feet and shall not be permanently dead-ended. Looping of the distribution grid shall be at least every 600 feet.

**10 inches and Up:** As required for primary feeder lines in subdivisions, industrial and commercial areas.

Velocity in distribution mains shall be designed not to exceed 5 feet per second. Velocity in service lines, as defined in Subsection 4.0.5 (Water Service Lines), shall not exceed 10' per second. Standard trench section (standard drawing 402) will be utilized for all water pipe installed.

New construction and reconstruction of light rail and freight rail may require improvements to the water system at utility crossing locations. Existing pipes in the second half of their useful life within the rail zones must be replaced to current standards. Metallic or conductive pipe materials are not approved pipe materials at light rail crossings.

All waterlines are to be encased through rail line crossings. Each casing pipe segment is to be positioned under rail tracks to avoid joints underneath rail lines. Metallic or conductive pipe materials are not typically approved at rail crossings (including pipes used as encasement conduit). If steel casing is selected, it shall be cathodically protected, but HDPE is generally preferred.

All water mains, lines and services and associated appurtenances within a radius of ten feet of any electrical line shall be cathodically protected. HDPE pipe is generally preferred.

#### **4.0.1.02 Grid System**

The distribution system mains shall be looped at all possible locations. All developments will be required to extend mains across existing or proposed streets for future extensions of other developments within OLWS. All terminations shall be planned and located such that new or existing pavement will not have to be cut in the future when the main is extended. The installation of permanent dead-end mains greater than 250 feet, upon which fire protection depends and the dependence of relatively large areas on single mains, will not be permitted. To create a grid for existing, proposed and any potential connection, OLWS may require public utilities and/or associated easement(s) to extend to the farthest property line or the most proximate or logical property line to connect to existing, planned, or potential utility lines.

#### **4.0.1.03 Dead-End Mains**

Dead-end mains which will be extended in the future shall be provided with a properly sized blowoff (see standard drawings 413).

Permanent dead-end mains shall terminate with a standard blowoff assembly (see standard drawing 413).



#### **4.0.1.04 Restrained Joints**

All fittings such as bends, tees, crosses, solid sleeves, valves, hydrants, blow offs, etc must be restrained by Megalug or Romagrip joint restraint glands. Thrust blocking and / or “rodding” will not be accepted as an alternative.

Thrust blocking will be required only behind tap saddles for new main and service installations 4 inches and larger.

Thrust blocking may also be required when an existing unrestrained main is modified and the potential for movement is increased. A saddle block may be required to anchor the unrestrained main in place.

All bell & spigot joints must be restrained by Field LOK (or equivalent) gaskets.

### **4.0.2 Alignment and Cover**

#### **4.0.2.01 Right-of-Way Location**

Water systems shall be located south and east from the right-of-way centerline or as directed by the Engineer. Generally, the waterline will be located 4 feet from curblin e or edge of pavement. Except as provided in Subsection 4.0.2.04 (Easements), all waterlines shall be in the public right-of-way.

Curved alignment for waterlines or mains is permitted and shall follow the street centerline when practical. The minimum allowed radius shall be based on allowable pipe deflection for the pipe diameter and the pipe laying length, but not to exceed 3-degree joint deflection.

#### **4.0.2.02 Minimum Cover**

The standard minimum cover over buried water mains within the street right-of-way shall be 36 inches from finish grade.

The maximum cover over buried water mains within the street right-of-way shall be 48” from finish grade, unless circumstances require additional cover and is approved by the District Engineer. The minimum cover for mains in easements across private property shall be 48" from finish grade.

Finish grade shall normally mean the existing or proposed pavement elevation. Where the main is located in the cut or fill side slope or where mains are located in easements, finish grade shall mean final ground elevation at the water main alignment.

#### **4.0.2.03 Separation with Sewer Lines**

Water mains shall be installed a minimum clear distance of 5 feet horizontally from sanitary sewers, and shall be installed to go over the top of such sewers with a minimum of 18 inches of clearance at intersections of these pipes. When physical conditions render this spacing impossible or impractical, then ductile-iron water pipe with watertight joints or concrete encasements is required for the sewer line. Wherever it is

necessary for sewer and water lines to cross each other, the crossing should be at an angle of approximately 90 degrees and the sewer shall either be located 18 inches or more below the water line or be constructed of ductile-iron water pipe with watertight joints for a distance of 9 feet on both sides of the water line. Exceptions shall first be approved by the District Engineer. In all instances, the distances shall be measured edge to edge. The minimum spacing between water mains and storm drains, gas lines, and other underground utilities, excepting sanitary sewers, shall be 3 feet horizontally when the standard utility location cannot be maintained.

Where water mains are being designed for installation parallel with other water mains, utility pipe, or conduit lines, the vertical separation shall be 12 inches below or in such a manner which will permit future side connections of mains, hydrants, or services, and avoid conflicts with parallel utilities without abrupt changes in vertical grade of the above mentioned main, hydrant, or service. Where crossing of utilities are required, the minimum vertical clearance shall be 6 inches.

#### **4.0.2.04 Easements**

Mains placed in easements along a property line, shall have easements centered on the property line and shall be offset 18 inches from the property line. Mains placed in easements along a right-of-way line shall be offset a minimum 3 feet from the right-of-way line and within a minimum 10-foot-wide easement. For mains placed in easements located other than along a property or right-of-way line, the main shall be placed in the center of the easement. Easements, when required, shall be exclusive and a minimum of 20 feet in width. The conditions of the easement shall be such that the easement shall not be used for any purpose which would interfere with the unrestricted use for water main purposes. Under no circumstances shall a building or structure be placed over a water main or water main easement. This includes overhanging structures with footings located outside the easement.

Easement locations for public mains serving a Planned Unit Development, apartment complex, or commercial/industrial development shall be in parking lots, private drives, or similar open areas which will permit unobstructed vehicle access for maintenance by OLWS personnel.

All easements must be furnished to the OLWS General Manager for review and approval prior to recording.

### **4.0.3 Appurtenances**

#### **4.0.3.01 Valves**

Valves shall be the same size as the mains in which they are installed. Valve types and materials shall conform to the Design and Construction Standards.

Distribution system valves shall be located at the tee or cross fitting. There shall be a sufficient number of valves so located that not more than 4, and preferably 3 valves,

must be operated to affect any one particular shutdown. The spacing of valves shall be such that the length of any one particular shutdown shall not exceed 500 feet. -

Valves shall be installed at each cross, tee, or any tap 2 inches or greater in diameter connected to the main line. Intersections shall be valved in at least 2 branches and cross-intersections shall be valved at all branches. Transmission water mains shall have valves at not more than 1,000-foot spacings. Hazardous crossings such as creeks, railroad and freeway crossings, shall be valved on each side.

Distribution tees and crosses for future branch lines on transmission mains may be required at the direction of the District Engineer.

#### **4.0.3.02 Fire Hydrants**

The water system shall be designed to provide adequate flow as required. The distribution system shall be designed in commercial/industrial areas to accommodate fire flows up to 1,500 GPM. Minimum fire flow in single-family residential areas shall be 1,000 GPM.

The distribution of hydrants shall be based upon the Oregon Fire Code Section 507.5.1 through 507.5.6. See Appendix C<sup>1</sup>

Residential hydrants shall be located as nearly as possible to the corner of street intersections and not more than 500 feet from any cul-de-sac radius point.

No fire hydrant shall be installed on a main of less than 6" inside diameter. The hydrant lead shall be a minimum 6" inside diameter.

All fire hydrants will be located behind the existing or proposed sidewalk or in the planter strip. Hydrants shall be placed as to not interfere with driveways and curb ramps. If any public hydrant encroaches on private property, an easement will be provided as directed by the District Engineer.

No hydrant shall be installed within 5' of any existing aboveground utility and there shall not be any utility facilities installed closer than 5' from an existing hydrant.

Hydrant installation shall conform to standard drawing 411. Full-depth hydrants will be required in all installations. Installation of hydrant extensions will not be allowed, unless approved by the District Engineer.

Hydrants shall not be located within 20' of any building and shall not be blocked by parking. The large hydrant port should face the road or travelway.

Guard posts shall adhere to Oregon Fire Code section 507<sup>2</sup>.

Use of posts other than at the 4 corners may be approved by the District Engineer.

---

<sup>1</sup> Or equivalent

<sup>2</sup> Or equivalent

#### **4.0.3.03 Pressure-Reducing and Air Release Valves**

The OLWS water distribution system is divided into separate pressure zones. Where water systems cross these zone lines, a pressure-reducing valve station will be required. The specific design and location for such valves will be reviewed and approved by the District Engineer.

When designated by the District Engineer, air release valves, per standard drawing 413, shall be installed. Such valves will be required on large diameter lines at all high points in grade.

#### **4.0.4 Backflow Prevention**

The type of backflow prevention assembly required is determined by the hazard level, and the potential for back siphonage, backpressure, or both.

Generally, all commercial accounts or any meter 1.5 inches and larger is required to install a backflow device at the property line.

##### **4.0.4.01 Typical Conditions Requiring Backflow Protection.**

An approved, customer owned and maintained backflow prevention assembly shall be installed on domestic, irrigation or fire service line(s) to premises when any of the following conditions exist:

- a. Premises with activities included in Table 42 of OAR 333-061-0070<sup>3</sup>.
- b. There is an auxiliary water supply, such as a well, cistern, or body of water on the property.
- c. There is intricate or inaccessible piping, which makes it impractical to ascertain whether or not a cross-connection exists.
- d. There is an elevation difference between the service connection at the public water main and the highest water outlet on the property that exceeds 30-feet.
- e. There is a risk of back siphonage or backpressure due to practices or equipment.
- f. There is an actual or potential cross-connection that presents a health hazard.
- g. There is an irrigation system.
- h. There is a water storage tank or bulk water filling station for vehicles and/or equipment.
- i. There is a temporary water supply provided for construction use.
- j. There is a fire line, fire sprinkler system, or private fire hydrant on the premises.

---

<sup>3</sup> At time of adoption.

k. There are materials or chemicals on site which present a potential hazard to the water supply.

l. There is a boiler on the property

#### **4.0.5 Water Service Lines**

The sizes of water service lines which may be used are  $\frac{3}{4}$ , 1, 2, 4, 6, 8, 10, and 12 inches. Water service lines will be reviewed for effects on the distribution system and shall not be greater in size than the distribution main.

A 2" water service line will be installed to serve a 1.5-inch meter.

A 4" water service line will be installed to serve a 3-inch meter.

For 3" and greater services, a design drawing must be submitted showing the vault and fitting requirements with the expected flow (normal and maximum day flow) requirements and proposed usage.

Domestic service lines 3/4" through 2" shall normally extend from the main to behind the curb, with a OLWS meter stop and meter box located at the termination of the service connection (standard drawings 420). Meter to be provided and installed by OLWS. Meter boxes and any required adaptors are to be provided by the developer. In general, individual service connections shall terminate in front of the property to be served and shall be located 18 inches each side of a common side property line.

When a corrosive potential condition is encountered and the copper service passes over or under an active cathodic protection system, the service will be installed in a Schedule 40 PVC conduit for a distance of 10 feet on each side of the active system. All conduit placements will be as-built.

Unless otherwise specified, any new tap must be located a minimum of 18 inches from other water service taps and main line joints, valves, and fittings.

Any service must leave the main at a 90 degree angle and run straight from the corp stop to the meter. The service must be centered in the trench.

The meter box and service must be located in front of the property served and a minimum of 18 inches away from a property corner.

The top of the OLWS meter stop must be installed 7 inches to 9 inches below finished grade.

##### **4.0.5.01 Fire Service**

There are 4 categories of private fire services: 1) hydrants, 2) fire sprinkler lines, 3) combination hydrant and fire sprinkler lines, and 4) combination plumbing and fire sprinkler heads.

The water fire service line shall normally extend from the main to the property line and end with a vault metering device and valves. An approved backflow prevention device will be required of the property being served.

Single family dwellings that are sprinkled shall construct a separate fire service of 1-inch minimum diameter.

“Flow-through” sprinklers may combine the domestic and fire services for single family dwellings.

Individual taps or connections should have a minimum separation of 1.5 feet as measured from the outside of the pipes.

#### **4.0.5.02 Fire Vaults Below Ground**

A vault will be required when a development or redevelopment proposes fire sprinklers and/or a service equal to or greater than 1-inch diameter. The vault drawing will be included on construction drawings submitted to OLWS. The vault shall contain all valves, fittings, meters, and appurtenances required for fire service to the development. Oak Lodge reviews vaults and Double Detector Check Valve Assembly for detector meter clearance. Oak Lodge replaces and installs the factory meters at its expense.

- a. 1-inch fire services require a 13-inch x 24-inch valve box or larger.
- b. Oak Lodge requires public access to the meter for reading purposes. The vault shall be located one-half in the public ROW or adjacent to the public ROW in a public easement dedicated to Oak Lodge or the public. The easement shall be recorded on the property plat.
- c. Installation Location: Double Check Backflow Prevention Assemblies (DC) and Reduced Pressure Principle Backflow Prevention Assemblies (RP) of size 2.5-inch and smaller shall be installed at the water service connection on the customer side of the water meter per UPC and OAR 333-061-0070 and OAR 333-061-0071. Assemblies must not be immersed in water and must be protected from freezing during cold weather.
- d. DCs and RPs of size 3-inch and larger shall be installed in a vault or aboveground housing per Uniform Plumbing Code (UPC) and OAR 33-061-0070 and OAR 336-061-0071<sup>4</sup> at the water service connection on the customer side of the water meter.
- e. Below-Grade Vault inlet and outlet pipe spools shall be ductile iron, flange by plain end. The assembly must be flanged.
- f. Clearance between the assembly and interior vault wall shall be a minimum of 12 inches.
- g. Clearance between the test cock side of the assembly and the interior vault wall shall be a minimum of 24 inches.
- h. Clearance from the bottom of the backflow assembly to the floor shall be a minimum of 12 inches and the device must be supported with stand-on pipe supports.
- i. When outside stem/screw and yoke (OS&Y) rising stem valves are used, clearance from a fully opened stem to the top of the vault lid shall be a minimum of three inches.

---

<sup>4</sup> At time of adoption.

- j. The vault must have adequate drainage to prevent the assembly from becoming submerged in water.
- k. RPs and Reduced Pressure Detector Assemblies must have an approved bore-sighted drain to daylight with a rodent screen.
- l. If a bore-sighted drain to daylight is not feasible for a DC or Double Check Detector Assembly installation, then a sump pump will be required.
- m. Plugs shall be installed on test cocks of below-ground installations, with no dissimilar metals.

#### **4.0.5.03 Fire Vaults Above Grade Installation**

- a. The assembly must have the District Engineer’s approval.
- b. The inlet and outlet pipe spools shall be ductile iron, flange by plain end. The assembly must be flanged.
- c. Underground 90 degree bends shall be restrained with mechanical joint restraint. Above ground 90 degree bends shall be flanged.
- d. The backflow assembly must be installed horizontal and plumb, unless otherwise allowed by OAR 333-061-0071<sup>5</sup>.
- e. The enclosure shall be installed on a concrete slab with a minimum thickness of six inches and a minimum compressive strength of 3,000 psi. The slab shall be poured on a 4-inch leveling course of 3/4-inch crushed, compacted rock.
- f. Clearance between the assembly and interior vault wall shall be a minimum of 12 inches.
- g. Clearance between the test cock side of the assembly and the interior vault wall shall be a minimum of 24 inches.
- h. Clearance from the bottom of the backflow device to the floor shall be between 12 and 60 inches.
- i. The backflow assembly shall be supported by stand-on pipe supports.
- j. The enclosure shall include an adequate bore sighted drain hole.
- k. The enclosure shall be insulated or have a heat source to maintain enclosure at 40 degrees Fahrenheit. The assembly shall be easily accessible.
- l. All structures and wiring shall comply with local building codes.

#### **4.0.5.04 Installation of Double Check Detector Assemblies and Reduced Pressure Detector Assemblies**

- a. Detector meters shall be installed with all Reduced Pressure Detector Assemblies, Double Check Detector Assemblies, and any other applicable assemblies.
- b. The detector meter will be supplied by OLWS.

**Air Gaps:** All air gaps must be approved by OLWS.

- a. The air gap shall provide a physical separation between the free-flowing discharge end of a potable water supply pipeline and an open or non-pressure receiving vessel.

---

<sup>5</sup> At time of adoption.

- b. The air gap size shall be a minimum of twice the diameter of the supply pipe, as measured vertically above the overflow rim of the vessel, and in no case shall be less than one inch.
- c. The air gap shall be installed away from walls or other obstructions that may restrict the air flow into the outlet pipe and nullify the air gap effectiveness.

#### **4.0.6 System Testing**

All new water systems (lines, valves, hydrants, and services) shall be individually pressure tested, chlorinated, and tested for bacteria. All testing shall be performed in accordance with Division 4 (Water Construction Standards) of the Standard Construction Specifications and in the presence of an OLWS Inspector. Services and hydrant lines 20 feet or less in length and services 2 inches and less in diameter will not be disinfected to the same requirements as longer and larger services and lines.

#### **4.0.7 Water Quality Sampling Stations**

Water sampling stations will be required as directed by OLWS. See Drawing No 435.

#### **4.0.8 Water Service/Permit Application Meters**

The owner of the premises to be served, or the owner's duly authorized agent, will apply for water service from OLWS. No service will be provided until OLWS approves the application and required payments are made.

OLWS will provide water service only from mains located within public roads, streets, alleys, or public easements, public right-of-way, and to property abutting such mains, and to dwellings, and other structures, and premises fronting such thoroughfares with sufficient frontages on the same to provide for appropriate service from such thoroughfares.

All applications will include the signature of the applicant, the location of the premises for which the service is requested, the address to which all bills be sent, and such additional data. Failure to supply such information and any additional needed by OLWS to make a determination, when requested shall be deemed sufficient cause to deny the application.

Applications for service will be considered merely as a request for service, and will not bind OLWS or Board, to provide such service. Charges made for the installation of water service will be paid in full before installation.

OLWS will not permit so-called "spider connections" which would provide service from one road or street, to premises abutting, or dwellings fronting, on another road or street. OLWS will provide each dwelling with a separate service connection, and no other occupant of such dwelling, will furnish water to any other dwelling, or premise.

Meters will be set per OLWS specifications. The service pipe from the main to the meter, as well the meter and the meter box will be the property of OLWS and not the person owning the premises or paying for the installation.



The contractor is responsible for the proper placement of the OLWS meter stop in relation to the curb, sidewalk, property line, and finished grade. If the OLWS determines that the meter stop location or depth are not acceptable, the contractor must relocate the meter stop and other related parts at no expense to OLWS. Extending the service line by use of a union or shortening the service line by bending it to use up excess length is not acceptable.

Water service installations for ¾-inch service to 2-inch service shall adhere to the following procedures:

- A Utility Placement Permit must be obtained from Clackamas County prior to construction in the road right of way.
- The installer is to schedule a preconstruction meeting with the OLWS inspector.
- The installer must request the tap installation and all inspections a minimum of 24 hours ahead of time through OLWS's Accela Citizen Portal: <https://aca.accela.com/OLWSD/Default.aspx>. No inspections will be performed after 2 pm.
- The corporation stop on the main line will be supplied and installed by OLWS. The contractor is responsible for all aspects of the excavation, traffic control, and adherence to safety regulations. The excavation for the tap must be a minimum of 3 feet wide by 6 feet long with 1 foot clear behind the main and 1 foot clear below the main. If OLWS determines that the work site does not meet their access or safety standards they will not install the tap.

#### **4.0.8.01 Water Service Connection**

Water services shall be installed as described in 4.3070 Copper Service Installation of these Design and Construction Standards.

Unless otherwise requested and approved in writing, service connections will be 1-inch and meters will be sized according to fixture units with such fittings, connections, a meter box, meter stops, etc. as OLWS may require.

When in the judgement of OLWS personnel, unusual conditions exist which require greater attention, extra fittings, meter boxes, vaults, or other safeguards, to assure adequate volume and pressure of water to an individual service, and or to minimize repair and maintenance problems, inherent in the installation, OLWS may require the applicant to meet the cost of such additional fittings, meter vaults, or other safeguards.,

When meters are required to be installed in driveways or roadways or under other circumstances, that in the opinion of OLWS personnel may cause unusual installation or maintenance problems, OLWS will have the right to require concrete meter vaults, with traffic-rated lids or other devices to likewise be installed. The cost of such vaults or other protective devices will be borne by the owner of the property requesting the service installation.

Services larger than 1-inch, may, at the discretion of the Board, be installed when requested in writing, provided the system can adequately serve such larger connections without interfering with the water service of others. The charges made for the installation of larger services will be sufficient to cover all costs thereof, and the minimum or "ready to serve/ charge" will be higher than for standard 1-inch service connections.

The Board may require persons requesting large service connections for fire protection, to pay for an equitable portion of the cost of feeder mains needed to supply the required flow. Each such case will be considered separately on its merits and the circumstances applicable to the case. The Board may also enter into special service contracts, in which higher minimum charges are established sufficient to cover the cost of the service rendered.

Replacement services and/or connections are to be dismantled by the property owner and at the owner's expense and inspected by OLWS.

All OLWS rules, and regulations rates and charges are subject to change or modification by the Board. All special contracts will be in writing, signed by the proper person, or customer and OLWS.

An OLWS representative must see the entire installation before it is backfilled. Any portion of the installation that has been covered prior to inspection must be exposed for inspection.

The water service must have a minimum 30 inches of cover. 24 inches of cover is permissible under a storm drainage ditch. Maximum cover is 48 inches.

No crimps or dents in the copper are acceptable.

The service must have a minimum of 6 inches of ¾-inch-0-inch ("3/4-minus") bedding underneath.

The meter stops on both sides of the meter must be positioned with the valve nut straight up to allow for proper operation.

The meter must be centered within the meter box.

The customer-side plumbing connecting to the downstream side of the meter must be either copper or PEX (no PVC pipe is acceptable inside the meter box).

The contractor is to supply all parts except for the corporation stop, the meter, and the customer-side meter stop.

## **4.1 GENERAL CONSTRUCTION**

---

The following specifications, in conjunction with applicable requirements of other parts of the contract documents, the plans, and addenda, shall govern the character and quality of material, equipment and construction procedures for water work. All work done shall be in compliance

with the requirements and restraints of OSHA, the State of Oregon Accident Prevention Division regulations and the Workers' Compensation Board. In addition, all work shall be completed in conformance with State of Oregon, Clackamas County, and/or City of Milwaukie and/or City of Gladstone street opening permits.

## **4.2 WATER WORKS MATERIALS**

---

### **4.2.1 Ductile-Iron Fittings**

All fittings shall conform to ANSI/AWWA Specification C110/A21.10 or ANSI/AWWA Specification C153/A21.53. All ductile-iron fittings shall be Class 350. Fittings shall be furnished with flanged or mechanical joints as specified on the plans. Fittings shall be ductile-iron fittings conforming to AWWA C110 and for compact C153. Fusion bonded epoxy fittings shall be U.S. pipe Permafuse or equal. Fittings shall be factory lined with cement mortar or cement lined to factory standards. No field coating with cement will be approved, other than for minor repairs. Fittings shall be new and free of defects in coating, body, and lining. During installation, fittings shall be properly aligned and bolted securely to provide watertight joints.

Fittings must be manufactured to conform to ANSI/AWWA standards.

### **4.2.2 Mechanical Joints**

Mechanical joints, including accessory glands, gaskets, and bolts, shall conform to the requirements of ANSI/AWWA C111/A21.11, except where specifically modified in AWWA C153 for compact ductile-iron fittings. As stated in AWWA C111, Tbolts shall be made of either high strength cast iron containing a minimum of 0.50% copper, or high strength, low alloy, steel. Bolts shall be marked to identify material and producer. Contractor shall provide OLWS with the bolt manufacturer's specifications, which shall give the following information: manufacturer's name, type of material, and identifying mark. Follower glands for mechanical joints shall be domestic made only.

Mechanical joint gaskets shall be made of vulcanized synthetic rubber and shall be no more than 3 years old.

The recommended installation procedures in AWWA specification C111, Appendix A, "Notes on Installation of Mechanical Joints," including bolt torque ranges, shall be followed.

#### **4.2.2.01 Megalug/RomaGrip Pipe Restraint**

RomaGrip/Megalug glands shall be RomaGrip/Megalug brand, as manufactured by Romac/Ebaa Iron Sales, Inc., or approved equal. RomaGrip/Megalug shall be used on ductile-iron pipe and fittings.

### **4.2.3 Flanged Joints**

Flanges shall conform to ANSI specification B16.1 for Class 125 flanges and shall conform in all other respects to ANSI/AWWA C110/A21.11. Bolts for assembly of flanged joints shall be of the size and quantity shown in Table 10.14 on Page 34 of AWWA C110. As stated in AWWA C110,

bolts shall conform to ANSI B18.2.1, Square and Hex Bolts and Screws Inch Series, Including Hex Cap Screws and Lag Screws. Nuts shall conform to ANSI B18.2.2, Square and Hex Nuts. Threads shall conform to ANSI B1.1, Standard for Unified Inch Screw Threads (UN and UNR Thread Form), Class 2A, external, and Class 2B, internal.

Bolts and nuts shall be of low-carbon steel conforming to the requirements of ASTM A307, Standard Specifications for Carbon Steel Bolts and Studs, 60,000 PSI Tensile Strength, Grade B. All buried flange nuts and bolts shall receive a protective coating of an approved spray-on, auto-body asphalt undercoating. Protective coating shall be dried and cured before fitting is placed and covered

Contractor shall provide OLWS with the manufacturer's specifications regarding the bolts to be used on the project.

Flange gaskets shall be full face, 0.125-inch thick, red rubber or approved equal.

#### **4.2.4 Flanged Pipe or Spools**

Flanged pipe or spools shall conform to the latest edition of ANSI/ANWA C115/A21.15. Flanges shall conform to requirements as specified in Subsection 402.04 (Flanged Joints). Pipe used shall be Class 53 DI. Pipe shall be furnished with coatings as specified in "Ductile-Iron Pipe". Threads on the flanges and pipe barrel shall be taper pipe threads (NPT) in accordance with ANSI B1.20.1.

When ordering, the following minimum information shall be provided to the manufacturer: Pipe size and finished length (flg. to flg., flg. to p.e.).

Manufacturer shall provide the following information: Length and weight shown on each pipe, flange manufacturer marking, country where cast, and DI or CI stamped on flanges. If fabricator is other than flange manufacturer, fabricator's mark shall be stamped with metal die on each flange after assembly. Also, manufacturer shall provide statement that the flange pipe complies with the specified standards.

#### **4.2.5 Ductile-Iron Pipe**

Ductile-iron pipe shall be Class 52. Physical properties shall not be less than 604210 iron and pipe shall conform to the latest revision of ANSI/AWWA specification C151/A21.51. Ductile-iron pipe shall be factory lined with cement mortar and bituminous seal coat and coated outside with asphaltic seal coat. Pushon rubber gasketed joints shall be installed using field-lok or approved equal locking gaskets. Pushon and mechanical pipe joints shall conform to ANSI/AWWA Specification C111/A21.11 and flanged joints shall conform to ANSI/AWWA C115/A21.15.

#### **4.2.6 Valves (General)**

All valves shall be designed to AWWA specifications and shall have standard 2-inch square operating nut unless otherwise shown on the plans. All pipe valves and fittings shall be pressure

rated at 250 to 350 PSI and shall open counter clockwise. All fittings shall be factory cement lined and coated.

#### **4.2.6.01 Gate Valves**

2-inch gate valves shall be resilient wedge double disc, non-rising stem with "O" ring packing, complying with AWWA Class C specifications. Gate valves 4-inch through 10-inch shall be resilient wedge, non-rising stem with "O" ring packing, complying with AWWA Class C specifications. The valves shall be designed to withstand water working pressures of 150 PSI or more. All valves shall be furnished with a 2-inch-square operating nut and shall open counter-clockwise when viewing valve from above. All valves shall be Mueller or approved equal.

Operation of the valve shall permit full withdrawal of the disc from the waterway to provide a clear unrestricted passage when the valve is in the open position. The valve shall be furnished with mechanical joint ends unless otherwise specified. Where flanges are furnished on valves, they shall conform to ANSI Specification B16.1, Class 125.

Valves located within vaults must have both hand wheel and rising stems.

#### **4.2.6.02 Butterfly Valves**

All butterfly valves shall be rubberseat type and bubbletight at 250 PSI pressure with flow in either direction. They shall be designed for direct burial and be satisfactory for application involving valve operation after long periods of inactivity. Valves shall conform to AWWA specification C504. All valves shall be Mueller or approved equal. Operating nut for the valve shall be located on the side of the main shown on the plans.

### **4.2.7 Fire Hydrant Assembly**

Fire hydrants shall conform to AWWA specification C502. The hydrants shall have a 5.25-inch minimum valve opening with a 6-inch mechanical joint inlet, a 6-inch mechanical joint by flanged resilient wedge auxiliary gate valve, two 2.5-inch hose nozzles, one 4.5-inch pumper nozzle, a 1.5-inch pentagon operating nut (opening counter clockwise), and a safety flange. The hydrant color shall be yellow (Rust-oleum V7400 alkyd enamel, fire hydrant yellow, or approved equal). The fire hydrant depth of bury shall be arranged to match the grade of the surrounding ground. See standard drawing no. 411 for additional requirements.

Fire hydrants shall be Kennedy Guardian K-81D, M&H 929 Reliant, or Clow Medallion F-2545. No other manufacturer will be accepted by OLWS.

### **4.2.8 Cast-Iron Valve Boxes**

Valve boxes shall be manufactured using domestic cast iron only. Valve boxes shall be the cast iron 18-inch tall casting with standard lid. Valve riser pipe from the valve to the cast-iron top shall be 6-inch PVC sewer pipe or approved equal for the box. See standard drawing no. 410.

Valve box castings shall be smooth and uniform. Box lid shall not protrude above the rim and lids shall seat flat without rocking. Lid will be stamped with a W. Boxes of uneven thickness,

pitted, or otherwise flawed in the casting will be rejected. PVC sewer pipe shall be cut off smooth with no sharp edges.

#### **4.2.9 2-inch Service Saddles**

Generally, 2-inch water services shall be connected with a 2-inch resilient wedge iron-bodied gate valve with a standard 2-inch square operating nut at the main. The gate valve will have female iron pipe thread connections. Service saddles may be approved by the District Engineer. Where approved, service saddles shall be 2-inch female iron pipe threads, double strap, stainless steel, Romac 202S or approved equal. Body of saddle shall be ductile iron coated with nylon, and straps, bolts, washers, and nuts shall be stainless steel. The close brass nipple between the saddle and the gate valve will be designated “lead-free”, containing no more than 0.25% lead by a weighted average when used with respect to the wetted surfaces of pipe, fittings, and fixtures.

#### **4.2.10 Copper Pipe**

3/4-inch and 1-inch Service lines shall be soft temper, copper water tube Type K, meeting ASTM B88 specifications. 2-inch service lines shall be rigid copper water tube Type K, meeting ASTM B88 specifications. Type L tubing will not be accepted.

#### **4.2.11 Brass Fittings**

All brass components shall be designated “lead-free”, containing no more than 0.25% lead by a weighted average when used with respect to the wetted surfaces of pipe, fittings, and fixtures.

#### **4.2.12 Corporation Stops**

Corporation stops shall be used for 3/4-inch and 1-inch taps only. They shall be full-port ball style valves and tap directly into the main line with iron pipe threads.

#### **4.2.13 Meter Stops**

OLWS meter stops shall be full-port angle ball valves, with padlock wings (meets ANSI/AWWA C800 Standard). The customer meter stops shall be full-port angle valves (either ball or ground key type valves are acceptable, and padlock wings are not required). For 3/4-inch service, a Ford BA43-332WQ or Mueller B-24258N is required. For a 1-inch service, a Ford BA43-444WQ or Mueller B-24258N is required. Either of these may be substituted if prior approval is provided from OLWS.

#### **4.2.14 Customer Side Plumbing**

Customer side plumbing within the meter box must be copper or PEX. PVC will not be accepted. The customer-side meter stop must be positioned with the valve nut straight up to allow for proper operation.

#### **4.2.15 Waterline Materials at Light Rail Crossings**

New and reconstructed light rail and freight rail construction may require improvements to the water system at all utility crossing locations. Each utility crossing area is to be minimized. All

existing water pipes or pipes within the rail zones shall be replaced to current standards and encased. Metallic or conductive pipe materials are not approved pipe materials at rail crossings. Pipes are to be centered under rail tracks to avoid joints underneath rail lines. All accessible structures must be located a minimum of 15' from the gate arms outside of the rail crossings.

## **4.3 CONSTRUCTION**

---

### **4.3.1 Storage of Equipment and Materials**

Unless otherwise noted on the plans or in the special provisions, it shall be the responsibility of the Contractor to locate a storage site for all equipment and materials and gain approval from the District Engineer.

Prior approval shall be obtained from the governing agency for any storage of equipment or materials within the right of way (i.e., stringing of pipe).

#### **4.3.1.01 INSPECTION**

All mains, services, valve, fittings, hydrants, and other appurtenances must be inspected by an OLWS representative before burial. Any installations backfilled prior to inspection must be excavated for OLWS inspection at the Contractor's expense.

### **4.3.2 Placing Pipe and Fittings**

The pipe shall be laid true to line, without objectionable breaks in grade and shall be firmly bedded for the entire length of the pipe.

All pipe shall be bedded and covered with 0.75-inch minus crushed aggregate to a depth of 6-inches on all sides.

Where conflicts arise between the designed grade of the waterline and an existing underground structure, the depth of the trench may be increased to permit proper installation of the waterline. Payment for over excavation shall begin once the extra depth reaches 18-inch below the designed grade.

Care shall be taken to clean joints and to keep them free of water during construction. Whenever water is excluded from the interior of the pipe, adequate backfill shall be deposited on the pipe to prevent floating. In the event of any flotation occurring, the pipe so affected shall be removed from the trench, replaced and relaid at the Contractor's expense.

Each section of the pipe and each fitting shall be thoroughly cleaned before it is lowered into the trench. Cleaning of each pipe or fitting shall be accomplished by swabbing out, brushing out, blowing out with compressed air, washing to remove all foreign matter. The most efficient method of cleaning out pipe and fittings will be determined on the job by the District Engineer.

If clean pipe sections and fittings cannot be placed in the trench without getting dirt into the open ends, the District Engineer will require that a piece of tightly woven canvas be tied over the ends of the pipe or fitting until it has been lowered into position in the trench. After the pipe or fitting has been lowered into the trench, all foreign matter shall be completely brushed

from the bell and spigot ends before assembly. At the end of each day, or during suspension of the work, the pipe ends shall be securely closed by means of a secure plug or approved equivalent. Water in the trench shall not be allowed to enter the pipe and fittings.

If it is necessary to cut the pipe to lay it on curves or to cause a change in direction, the Contractor shall cut the pipe as required for proper installation. Where the cut length of pipe is to be installed into the bell end of another pipe, the cut end shall be beveled to ensure a proper seal. To set valves and fittings properly, the pipe shall be cut to the exact length required to obtain the designated locations. The cost of cutting the pipe shall be included in the unit prices bid.

Dead end lines, where a standard 2-or-4-inch blow-off assembly is not required by the plans, shall be provided with a ¾-inch corporation stop 18 inches from the plugged end of the pipe. This will allow for air removal and release of line pressure during future waterline extension. No extra payment shall be made for this installation.

### **4.3.3 Wet Tapping Existing Main**

When specified, wet taps on existing water main are required to minimize interruption of service to customers. OLWS personnel will install ¾-inch and 1-inch corporation stops and 2-inch gate valves on live mains. OLWS approved contractors will install 4-inch and larger taps on live mains. Tapping sleeve and valve for 4-inch and larger taps shall conform to standard drawing no. 408.

Before attaching tapping sleeve, care shall be taken to clean water main of all debris and defects. Attach sleeve and valve to the main. Then attach proper tapping machine to valve. Pressure test this assembly before making tap. After making tap, remove the tapping machine and inspect fitting and valve for leaks. If any such leaks are found, Contractor shall be required to repair the defect. Attach branch main to valve and install pipe. New connections 4-inch and larger shall be securely thrust blocked using a poured block sized according to the system pressure and the size of the main or service installed. -Taps shall be made no closer than 18-inch from end of sleeve to nearest joint.

Excavation for tap shall be such as to fully expose main with a minimum depth below main of 12 inches. A minimum of 18-inch of main shall be exposed from the end of the tapping sleeve. Also, excavate enough area to accommodate tapping machine and workers. Backfilling shall be in accordance with OLWSD backfill standards.

### **4.3.4 Polyethylene Encasement of Pipe and Fittings**

When specified, install polyethylene encasement, tube type, on all pipe and appurtenances. Polyethylene film shall conform to ASTM standard specification D124878, having a minimum thickness of 0.008-inch (8 mil). Install this encasement in accordance with AWWA C105, Method A, 1 length of polyethylene tube for each length of pipe. When required, polyethylene tubing used on mains shall be held in place with 2 inch-wide adhesive tape which is compatible with polyethylene, with plastic binder twine, with nylon tie straps, or other method approved by the District Engineer.



The use of polyethylene sheets will not be allowed on pipe segments, only fittings. Sand backfill shall be placed within the pipe zone and bedding area wherever polyethylene encasement is used.

Polyethylene sheets may be used to cover valves, fittings, and all mechanical joints and flanged connections. Valves shall be wrapped up to the bottom of the operating nut. Three layers of polyethylene shall be wrapped snugly around the pipe and held in place by using an adhesive tape compatible with polyethylene, plastic binder twine, or nylon tie straps. Backfill material shall not be allowed to get under the polyethylene, and pockets in the polyethylene which can trap backfill material shall be eliminated.

#### **4.3.5 Placing Valve Units**

A valve unit shall consist of a valve, bolts, gaskets, followers, PVC riser pipe, and cast-iron valve box, complete with cover.

Valves shall be placed in a vertical position at locations shown on the plans. The Contractor shall check each valve to determine that the valve is properly adjusted to seat securely and open fully. Valves not meeting these requirements shall not be installed. Valve boxes and PVC riser pipe shall be placed in a vertical position over the valve operating nut and the backfill shall be carefully compacted around the box. Any valve boxes found off center from the valve operating nut shall be removed and replaced into the proper position. The top of the valve box shall be adjusted to meet finish grade. PVC riser pipe shall extend up inside the valve box 7 inches on the Vancouver box to allow future raising of the box. Notches shall be cut into the rim of the valve box on a line passing through the center of the box as detailed on standard drawing no. 313. Valve boxes shall be placed so that the notches line up parallel with the water main below. A collar of concrete with a depth of 4-inch, 24-inch x 24-inch square, shall be placed around the top of all valve boxes not in a paved area.

The Contractor shall not operate any valve touching potable water.

#### **4.3.6 Placing Fire Hydrant Assemblies**

The fire hydrant assembly shall consist of a mechanical joint hydrant, mechanical joint by flange auxiliary gate valve, cast-iron valve box, galvanized bolts, gaskets.

The fire hydrant shall be placed in a vertical position on a precast concrete block having a bearing surface of not less than 1 square foot. Hydrant drain holes shall not be blocked. Not less than 4 cubic feet of clean drain rock shall be placed around the base of the hydrant for drainage. The drain rock envelope must extend to 6-inch above the drain holes and must be fully wrapped in geotextile. See standard drawing no. 411 for other requirements. Fire hydrant extension kits may be installed with approval by the District Engineer. Where approved, fire hydrant extension kits may only be installed by OLWS water crews. In no instance will more than one fire hydrant extension kit per hydrant be installed.

### 4.3.7 Copper Service Installation

Where indicated on the drawings or as determined in the field, the Contractor will be required to install copper water services. This will require OLWS personnel or an approved contractor to install live taps (see 4.3030) as necessary. The Contractor will install the copper service pipe and OLWS meter stop and meter box.

All new copper pipe and service fittings shall be kept clean and free of debris. Where new services are installed, new meter boxes shall be set with the top of the box at finish grade. Meter boxes shall be located as follows, in order of preference:

1. Within the planter strip, excluding water quality facilities – with the OLWS Meter Stop located 18 inches behind the face of curb.
2. Behind the sidewalk in an approved area (either in the road right of way, a Public Utility Easement, or an OLWSD easement) - with the OLWS Meter Stop located 12-inch behind the back of sidewalk
3. In the sidewalk – with the OLWS Meter Stop located 18-inch behind the face of curb (or 12-inch behind the front of the sidewalk)
4. If there is no curb: 3/4-inch and 1-inch OLWS Meter Stops are to be located 40-inch outside of the property line, and 2-inch OLWS Meter Stops are to be located 50-inch outside of the property line
5. Depth: OLWS Meter Stops shall be installed with the top of the stop 7 to 9-inches below final grade

In addition:

1. The meter box must be located in front of the property served and a minimum of 18-inches away from a property corner.
2. The meter box shall not be located in a driveway or other areas where vehicle tires might pass over it (when suitable locations exist outside trafficked areas). The meter box must not be located in driveway approach wings.
3. The contractor is responsible for the proper placement of the OLWS meter stop in relation to the curb, sidewalk, or property line. If OLWS determines that the meter stop location or depth are not acceptable, the contractor must relocate the meter stop at no expense to OLWS. Extending the service line by use of a union or shortening the service line by bending it to use up excess length is not acceptable.

The meter box and cover required for a 3/4" meter shall be a DFW 11"X18"X12" gray "wide body" meter box part number DFW486WBC4-12-BODY; and a DFW 11"X18" gray solid meter box cover w/ magnet w/ ss pick hole pin part number DFW486C-4MP-LID.

The Meter box and cover required for a 1" meter shall be a DFW 13"X24"X12" gray meter box part number DFW1324C4-12-BODY and a DFW 13"x24" gray solid meter box cover w/magnet w/ss pick hole pin part number DFW1324C-4MP-LID.

All copper service pipe shall be bedded and covered with 0.75-inch minus crushed aggregate to a depth of 6 inches on all sides. If the service is located in a road right-of-way, all of the backfill will consist of 0.75-inch minus crushed aggregate.

Service lines shall be located in a direct line between the meter and a point on the main directly opposite the meter. Service lines shall have a minimum cover of 30 inches except where crossing road ditches where the cover may be reduced to 24 inches at said road ditch. The service line must be centered in the trench.

Where existing copper service is to be transferred to new main, and the existing main is to remain live, Contractor shall disconnect corporation stop from old main and install a lead-free brass plug. Contractor shall provide excavation down to old corporation stop, select backfill and compaction. Excavation and backfill shall be considered incidental to the project. Contractor shall perform surface restoration according to the bid item for that work.

All new services crossing existing metal gas lines shall have PVC sleeves as discussed on standard drawings no. 420.

Corporation stops shall be set at a 45 degree angle up from horizontal. Taps shall be a minimum distance of 18 inches from the bell or spigot end of the main, or from another service tap, or from any fitting.

Where a new section of copper service is to be installed, it shall be Type K, seamless soft annealed copper pipe conforming to ASTM B88. There shall be no splicing of copper unless the service is longer than 100 feet or as approved by the District Engineer (unique conditions). When splicing is approved between 2 pieces of copper, it shall be done with a 3 piece copper to copper union. No more than 1 splice per service shall be made and splicing shall be made outside of the existing or proposed travel lane. Existing galvanized service lines encountered by the Contractor shall be replaced with copper service pipe up to and through the angle meter stop.

Where 2-inch services are to be installed, the main shall be tapped thru a 2-inch service saddle and a 2-inch resilient wedge iron-bodied gate valve, have 2-inch type K rigid copper tubing and utilize a 2-inch full-port ball type angle meter stop with locking wings.

#### **4.3.8 Placing Permanent Blow-Off Assemblies**

A standard blow-off assembly shall consist of a main size x MJ cap tap, 2-inch x 1' brass nipple, 2-inch resilient wedge gate valve, 2-inch x 30-inch galvanized nipple, 2-inch galvanized 90° bend, 2-inch galvanized piping, 2 valve boxes, galvanized coupling and brass or PVC plug. The blow-off assembly shall be placed as shown in standard drawing no. 413.

#### **4.3.9 Removing Existing Water Works Materials**

When the Contractor removes existing pipe, gate valve units, fittings, fire hydrant units or other items to allow installation of the work specified herein, the Contractor shall haul the removed water works material away. Title to the removed materials shall transfer to the Contractor, except when otherwise specified.

OLWS reserves the right to designate other water works materials to be removed. The Contractor shall remove the designated water works materials and haul them to OLWS's designated storage yard.

#### **4.3.10 Abandoning Existing Mains and Valves**

Any existing water lines that are abandoned shall be severed and plugged as directed by the District Engineer. All abandoned valve boxes shall be removed, gravel filled, compacted, and asphalt plugged at no additional cost.

##### **4.3.10.01 Abandoning Existing Services**

3/4-inch and 1-inch services that are abandoned shall have the corp stop left in place and the copper service line severed within 2-inch of the corp stop.

1.5-inch and 2-inch services that are abandoned shall have the corp stop removed from the service saddle and the saddle plugged with a brass plug designated as 'lead-free', containing no more than .25% lead by a weighted average when used with respect to the wetted surfaces of pipe, fittings, and fixtures.

3-inch and larger services that are abandoned shall have the tee removed from the main line and the main then repaired with a section of solid pipe and MJ sleeves.

Abandoned meters and meter boxes are to be removed and returned to OLWS.

#### **4.3.11 Maintaining Service**

The Contractor shall schedule construction work specified herein to maintain a continuous water service to existing water users. Where it is necessary to shut down service to make required interties, the Contractor shall notify OLWS at least five working days prior to a planned water service shut down to allow OLWS to notify users of the impending loss of water service. Contractor may be required to make necessary service shutdowns of affected businesses after regular business hours at no additional cost to OLWS.

#### **4.3.12 Flushing**

The new pipeline shall be flushed, pressure tested, and disinfected before any connection to the existing water system is made. Temporary blow-offs and chlorination points shall be provided by Contractor at all dead ends and points of connection to the existing system. The new waterline shall be built as close as possible, as determined by the District Engineer, to the existing water system at points where connections are to be made.

All pipe, valves and fittings shall be thoroughly flushed prior to pressure testing and chlorination. Flushing shall be done through blow-off units, hydrants, individual services, and main at a minimum velocity of 2.5 F/S. All water used during flushing operations shall be measured through a Pitot Blade and stop watch. All results shall be reported to the District Engineer on a daily basis.

Prior to any flushing procedures taking place, the Contractor shall issue a flushing plan providing direction of flow, water damage control and a written schedule to the District

Engineer for approval. A 48 hour notice shall be given to the District Engineer prior to any system shutdown or flushing procedures. Under no circumstance shall the Contractor operate any OLWS valves without prior approval by the District Engineer.

The following chart shows minimum temporary blow-off/inlet sizes which shall be provided by the Contractor. Gate valves shall be provided on blow-off and inlet pipes to pressure test against, and to keep the pipe interior clean when backflow device is removed.

| <b>REQUIRED OPENINGS TO FLUSH PIPELINES</b> |  |   |
|---|--|---|
| <b>NOMINAL PIPE SIZE (INCHES)</b>           | <b>FLOW REQUIRED TO PRODUCE 2.5 FPS VELOCITY (GPM)</b> | <b>MINIMUM INLET &amp; OUTLET PIPE SIZE REQUIRED (INCHES)</b> |
| 4   | 110  | 2   |
| 6   | 240  | 2   |
| 8   | 430  | 4   |
| 10  | 660  | 4   |
| 12  | 950  | 4   |
| 14  | 1290   | 6   |
| 16  | 1690   | 6   |
| 18  | 2140   | 6   |
| 20  | 2640   | 6   |
| 24  | 3800   | 6   |

All flushing and testing water shall be delivered to the new waterline through Oregon State Health Division approved double check valve backflow prevention devices.

The Contractor shall provide or obtain a backflow prevention device. Certified backflow tester shall test device and furnish documentation to OLWS Construction Inspector after device is installed on site.

After flushing, the new system shall be pressure tested and disinfected. Payment for this item shall be included in the price bid for pipeline installation work.

### **4.3.13 Testing and Chlorination**

All of the pipe, fittings, services, and individual valves, except the last connection with the existing main, after being placed, must be pressure tested, conforming to AWWA C600 Section 4 specifications. If the Contractor elects to test the line in sections, the lengths of the sections and provisions for testing shall be subject to approval by the District Engineer.

Before testing the pipeline for leakage, the pipeline shall be thrust blocked. The interior of the pipeline shall be thoroughly cleaned to remove all foreign matter.

The Contractor shall furnish necessary thrust blocks, pumps, medium range pressure gauges, means of measuring water loss, and all other equipment, materials and labor required for making the tests.

All air vents shall be open during the filling of the pipeline with water. After a test section is completely filled, it shall be allowed to stand under slight pressure for at least 24 hours to allow the lining to absorb what water it will and to allow the escape of air from any small air pockets. During this period, the bulkheads, valves and exposed connections shall be examined for leaks. If any are found, they shall be stopped. The pressure shall then be raised slowly to the minimum hydrostatic pressure of 180 pounds per square inch, or 1.5 times the normal working pressure, whichever is higher, measured at the point of highest elevation and shall be maintained for a period of at least 1 hour, beginning at a time of day to be mutually agreed upon between the Contractor and the District Engineer.

Test pressure shall not exceed 150% of pipe pressure rating.

No leakage is acceptable. While the pipe is under pressure and stabilized, an inspection for leaks along the pipeline shall be made by the Contractor. The gauges should be graduated at 2 PSI increments. Any leaks found shall be recorded and shall be repaired by the Contractor. All such repairs shall be made subject to the approval of the District Engineer.

The Contractor, at their own expense, shall perform any excavation required to locate and repair leaks or other defects which may develop under the test. He shall remove backfill and paving already placed, shall replace such removed material, and shall make all repairs necessary to secure the required water tightness. All repairs and retests shall be made at the Contractor's sole expense.

All leakage tests shall be made in the presence of the District Engineer or OLWS Inspector.

The pipeline shall be thoroughly chlorinated and flushed in accordance with the Oregon State Health Division's publication, "Public Water Systems", ORS Chapter 333. The Contractor shall employ the use of storage tanks, basins, or other means to transport or treat the chlorinated water for discharge to an approved point of disposal. Adequate quantities of chlorine in a water solution shall be added to the pipeline and shall be allowed to stand a sufficient length of time to sterilize the interior of the pipeline. The chlorinated water shall be flushed from the pipeline and a water sample shall be taken from the pipeline. The water sample shall be tested biologically and an acceptable certification that the water is safe for domestic water consumption shall be obtained before placing the pipeline into service. If the water is not safe, the Contractor shall chlorinate and flush the line and take new samples until an acceptable safe water certification is obtained.

Chlorine may be applied by the following methods: Liquid chlorine gas/water mixture, direct chlorine gas feed, or calcium hypochlorite and water mixture. The chlorination agent shall be applied at the beginning of the section adjacent to the feeder connection and shall be injected through a corporation cock, hydrant, or other connection ensuring treatment of the entire line. Water shall be fed slowly into new line with chlorine applied in amounts to produce a dosage greater than 50 ppm but not more than 200 ppm throughout the system. After 24 hours, a

residual of not less than 25 ppm shall be produced in all parts of the line. If the check measurement taken after the 24-hour period indicates a free chlorine residual of less than 25 ppm, the system shall be flushed, rechlorinated, and rechecked until a final residual of 25 ppm or more is achieved and at no additional expense to OLWS.

During the chlorination process, all valves and accessories shall be operated. All parts of the line and services shall be chlorinated. After chlorination, the water shall be flushed from the line at its extremities until the replacement water tests are equal chemically and bacteriologically to those of the permanent source of supply. A minimum of 24 hours after dechlorination OLWS shall take two consecutive sets of samples, taken at least 24 hours apart. At least one set of samples shall be collected from every 1,200 feet of the new water main, plus one set from the end of the line, and one set from each branch. Water samples will be taken for bacteriological tests by OLWS.

The Contractor shall furnish and place all necessary fittings required for the testing, chlorinating and flushing of the pipeline. If a corporation stop is removed, the hole shall be filled with a lead-free brass plug.

Water used in testing and flushing the pipeline shall be purchased from OLWS.

#### **4.3.14 Cut-In and Connection to Existing Mains**

After new waterline is flushed, pressure tested and disinfected, but prior to any cut-in and connects, Contractor shall hold an onsite pre-connection meeting. Those to attend shall include onsite foreman, OLWS Inspector, OLWS Operations Personnel, and District Engineer.

This meeting shall take place prior to each connection and no longer than 1 week prior to the connection. At this meeting, Contractor shall have all fittings, pipe, chlorine swabbing equipment, pumps and hoses, and all equipment needed to make the cut-in connect. Cut-in schedule and shutdown coordination shall be discussed.

Once the bacteria test has been passed, cut-ins and connections to the existing water system shall be made by the Contractor. All fittings necessary for the cut-in and pumps adequate to handle water in the trench shall be on hand and ready for service before connection is commenced. If the new waterline is opened to the air before Contractor and OLWS personnel are ready to proceed with the connection, or if new waterline is contaminated by dirt or dirty water, the new waterline shall be disinfected again.

Fittings and pipe for cut-ins shall be swabbed out thoroughly with a 1% chlorine solution (½ pound of 64% calcium hypochlorite in 4 gallons of water). Swabbing equipment and solution shall be kept clean and fresh.

During each connection, work shall proceed without breaks until the connection is completed and water service is turned back on. Ground water shall not be allowed around any of the existing piping during the connection.

After the connection is completed and water service is turned back on, a visual leak inspection of all fittings shall be done by the Inspector prior to backfilling.

### **4.3.15 Clay Dams**

Where indicated on the plans, or as directed by the District Engineer, the Contractor shall place clay dams to prevent ground water movement along the trench. Dams shall be made of impervious backfill material composed of particles at least 50% of which pass a no. 200 sieve, and with a plasticity index not less than 20, unless otherwise indicated on the plans.

A dam shall fill the trench completely from side to side and top to bottom, except for the volume occupied by the pipeline and any materials required for surface restoration. Pipe in contact with clay dam will be wrapped with 2 layers of 8-mil polyethylene.

Flow shall be considered in design of water and storm drain system.

**END OF SECTION**



## **SECTION 5—STANDARD DRAWINGS**

|                           |                                       |
|---------------------------|---------------------------------------|
| <b>DRAWINGS 200 - 210</b> | <b>STORMWATER STANDARD DRAWINGS</b>   |
| <b>DRAWINGS 300 - 325</b> | <b>SEWER SYSTEM STANDARD DRAWINGS</b> |
| <b>DRAWINGS 400 - 435</b> | <b>WATER SYSTEM STANDARD DRAWINGS</b> |

# STORMWATER STANDARD DRAWING INDEX

- 200 STORMWATER STANDARD DRAWING INDEX
- 202 PLANTER INFILTRATION
- 204 RAINGARDEN INFILTRATION
- 206 VEGETATED SWALE INFILTRATION
- 207 FILTER STRIP
- 208 DRYWELL
- 209 SOAKAGE TRENCH
- 210 DETENTION POND



**STORMWATER STANDARD DRAWING**

## STORMWATER STANDARD DRAWING INDEX

| NO. | REVISIONS                          | DATE     | BY  |
|-----|------------------------------------|----------|-----|
| 1   | TITLE CHANGE, UPDATED DRAWING LIST | 8/8/2024 | TAP |
| 2   |                                    |          |     |
| 3   |                                    |          |     |
| 4   |                                    |          |     |

DRAWING NO.

**200**

DATE: 02/18/2020

SCALE: NTS

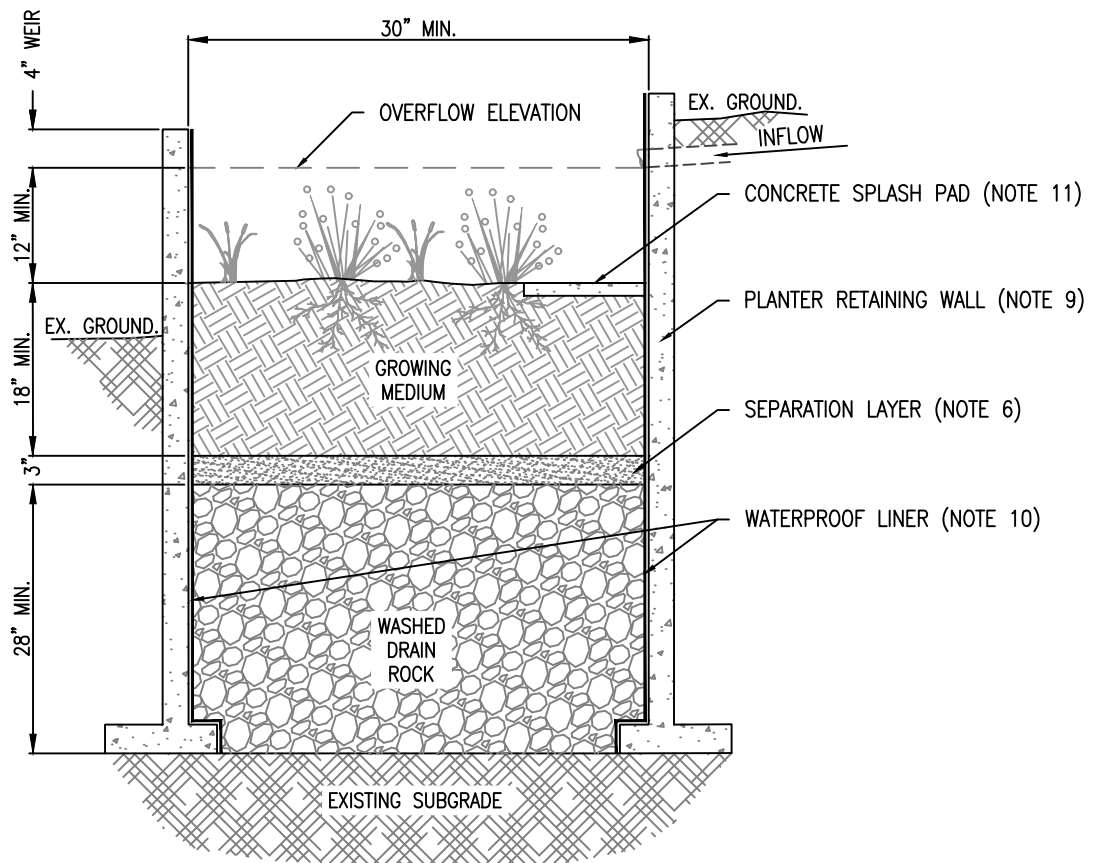

**NOTES:**

1. PROVIDE PROTECTION FROM ALL VEHICLE TRAFFIC, EQUIPMENT STAGING, AND FOOT TRAFFIC IN PROPOSED INFILTRATION AREAS PRIOR TO, DURING, AND AFTER CONSTRUCTION.
2. DIMENSIONS:  
 -WIDTH: 30" MINIMUM  
 -DEPTH OF PLANTER (FROM TOP OF GROWING MEDIUM TO OVERFLOW WEIR ELEVATION): 12"  
 -SLOPE OF PLANTER: 0.5% OR LESS
3. PLANTER MUST BE SETBACK A MINIMUM OF 5 FEET FROM PROPERTY LINE.
4. OVERFLOW WEIR ELEVATION MUST ALLOW FOR 4" OF FREEBOARD, MINIMUM. SIZE OVERFLOW WEIR FOR THE 100 YEAR DESIGN STORM. IDENTIFY EMERGENCY OVERFLOW ROUTE ON THE STORMWATER MANAGEMENT PLAN.
5. DRAIN ROCK SIZE: 1 1/2" - 3/4" WASHED WITH MINIMUM 28" DEPTH.
6. SEPARATION BETWEEN DRAIN ROCK AND GROWING MEDIUM SHALL BE A 3" LAYER OF 3/4" - 1/4" OPEN GRADED AGGREGATE.
7. GROWING MEDIUM WILL BE A MINIMUM 18" DEPTH. FACILITY SURFACE AREA MAY BE REDUCED BY 20% WHEN GROWING MEDIA DEPTH IS INCREASED TO 30" OR MORE.
8. VEGETATION WILL FOLLOW THE LANDSCAPE PLANS.
9. PLANTER WALL MATERIAL SHALL BE STONE, BRICK, CONCRETE OR OTHER DURABLE MATERIAL AND SHALL BE INCLUDED ON FOUNDATION PLANS. INSTALL INVERTED CURB AS NEEDED BETWEEN PLANTERS AND ROAD SUBGRADE. WALL HEIGHTS GREATER THAN 24" ABOVE GRADE REQUIRE HANDRAILS. SUBMIT RETAINING WALL DESIGN IN ACCORDANCE WITH APPLICABLE STRUCTURAL CODES FOR REVIEW AND APPROVAL.
10. WATERPROOF LINER SHALL BE 30 MIL PVC OR EQUIVALENT. A WATERPROOF LINER IS NOT REQUIRED IF THE WALL MATERIAL IS WATERPROOF REINFORCED CONCRETE OR APPROVED EQUAL.
11. INSTALL CONCRETE SPLASH PAD TO TRANSITION FROM INLET TO GROWING MEDIUM. SIZE OF PAD SHALL BE 1 FT X 1 FT.
12. SEASONAL HIGH GROUNDWATER SEPARATION DISTANCE AS REQUIRED.

**PLANTER INFILTRATION**

| NO. | REVISIONS | DATE | BY |
|-----|-----------|------|----|
| 1   |           |      |    |
| 2   |           |      |    |
| 3   |           |      |    |
| 4   |           |      |    |

DRAWING NO.

**202**

DATE: 4/10/2024

SCALE: NTS

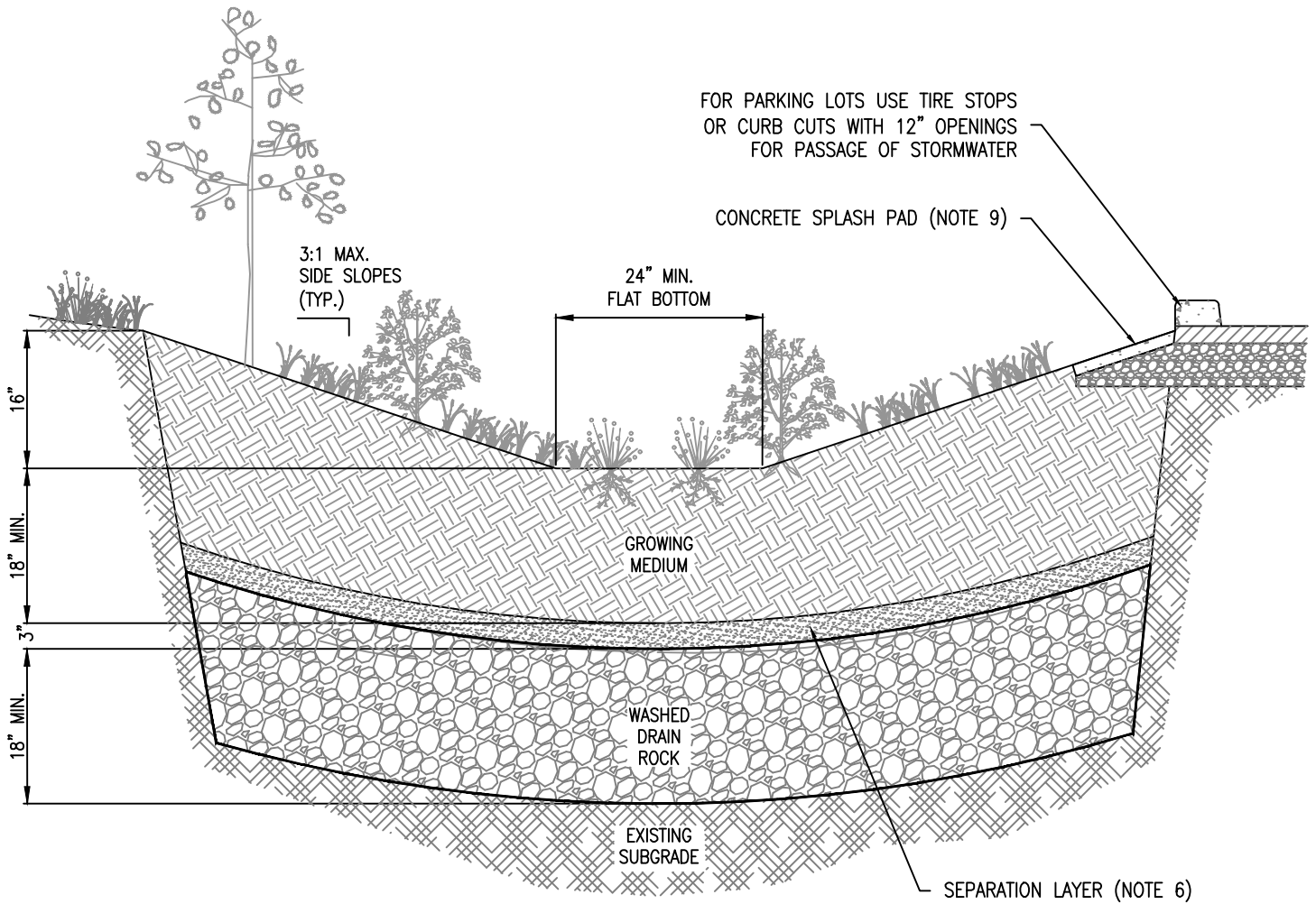

**NOTES:**

1. PROVIDE PROTECTION FROM ALL VEHICLE TRAFFIC, EQUIPMENT STAGING, AND FOOT TRAFFIC IN PROPOSED INFILTRATION AREAS PRIOR TO, DURING, AND AFTER CONSTRUCTION.
2. DIMENSIONS:
  - DEPTH OF BASIN (FROM TOP OF GROWING MEDIUM TO OVERFLOW ELEVATION): 16"
  - FLAT BOTTOM WIDTH: 24" MINIMUM
  - SIDE SLOPES OF BASIN: 3:1 MAXIMUM
  - SLOPE OF RAINGARDEN: 0.5% OR LESS
3. INFILTRATION RAINGARDEN MUST BE SETBACK A MINIMUM OF 10 FEET FROM FOUNDATIONS AND 5 FEET FROM PROPERTY LINE.
4. IDENTIFY EMERGENCY OVERFLOW ROUTE FOR THE 100 YEAR DESIGN STORM ON THE STORMWATER MANAGEMENT PLAN.
5. DRAIN ROCK SIZE: 1 1/2" - 3/4" WASHED WITH 18" DEPTH.
6. SEPARATION BETWEEN DRAIN ROCK AND GROWING MEDIUM SHALL BE A 3" LAYER OF 3/4" - 1/4" OPEN GRADED AGGREGATE.
7. GROWING MEDIUM WILL BE A MINIMUM 18" DEPTH. FACILITY SURFACE AREA MAY BE REDUCED BY 20% WHEN GROWING MEDIA DEPTH IS INCREASED TO 30" OR MORE.
8. VEGETATION WILL FOLLOW THE LANDSCAPE PLANS.
9. INSTALL CONCRETE SPLASH PAD TO TRANSITION FROM INLET TO GROWING MEDIUM.
10. SEASONAL HIGH GROUNDWATER SEPARATION DISTANCE AS REQUIRED.

| NO. | REVISIONS | DATE | BY |
|-----|-----------|------|----|
| 1   |           |      |    |
| 2   |           |      |    |
| 3   |           |      |    |
| 4   |           |      |    |

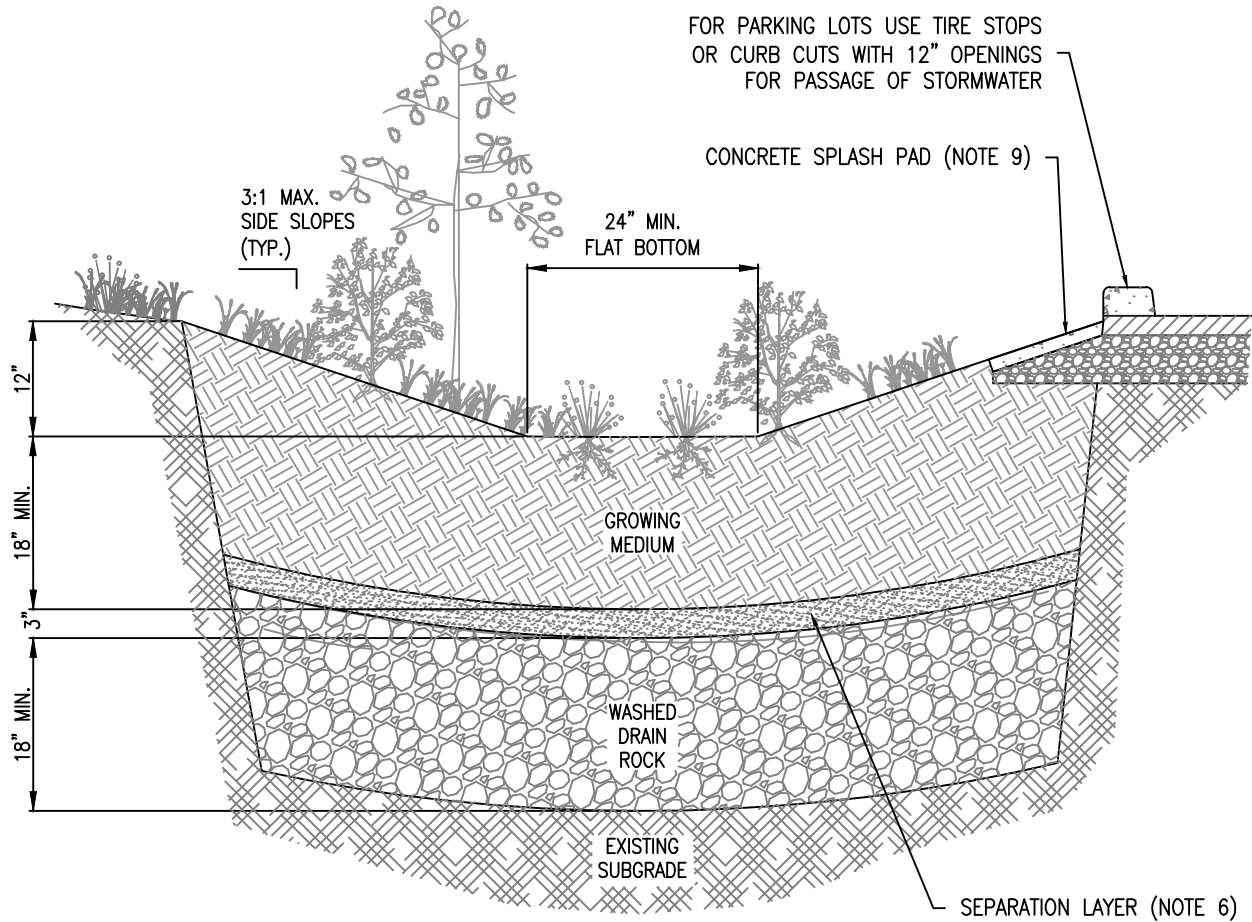

**NOTES:**

1. PROVIDE PROTECTION FROM ALL VEHICLE TRAFFIC, EQUIPMENT STAGING, AND FOOT TRAFFIC IN PROPOSED INFILTRATION AREAS PRIOR TO, DURING, AND AFTER CONSTRUCTION.
2. DIMENSIONS:
  - DEPTH OF SWALE (FROM TOP OF GROWING MEDIUM TO OVERFLOW ELEVATION): 12"
  - FLAT BOTTOM WIDTH: 24" MINIMUM
  - SIDE SLOPES OF SWALE: 3:1 MAXIMUM
  - LONGITUDINAL SLOPE OF SWALE: 6% OR LESS
3. INFILTRATION VEGETATED SWALES MUST BE SETBACK A MINIMUM OF 10 FEET FROM FOUNDATIONS AND 5 FEET FROM PROPERTY LINE.
4. IDENTIFY EMERGENCY OVERFLOW ROUTE FOR THE 100 YEAR DESIGN STORM ON THE STORMWATER MANAGEMENT PLAN.
5. DRAIN ROCK SIZE: 1 1/2" - 3/4" WASHED WITH 18" DEPTH.
6. SEPARATION BETWEEN DRAIN ROCK AND GROWING MEDIUM SHALL BE A 3" LAYER OF 3/4" - 1/4" OPEN GRADED AGGREGATE.
7. GROWING MEDIUM WILL BE A MINIMUM 18" DEPTH. FACILITY SURFACE AREA MAY BE REDUCED BY 20% WHEN GROWING MEDIA DEPTH IS INCREASED TO 30" OR MORE.
8. VEGETATION WILL FOLLOW THE LANDSCAPE PLANS.
9. INSTALL CONCRETE SPLASH PAD TO TRANSITION FROM INLET TO GROWING MEDIUM.
10. CHECK DAMS ARE REQUIRED FOR LONGITUDINAL SLOPES OVER 4% AND SHALL BE SPACED AT A MAXIMUM OF 2-FOOT ELEVATION INTERVALS. MAINTAIN 4-10 INCH DEEP ROCK CHECK DAMS AT DESIGN INTERVALS.
11. SEASONAL HIGH GROUNDWATER SEPARATION DISTANCE AS REQUIRED.

| NO. | REVISIONS | DATE | BY |
|-----|-----------|------|----|
| 1   |           |      |    |
| 2   |           |      |    |
| 3   |           |      |    |
| 4   |           |      |    |

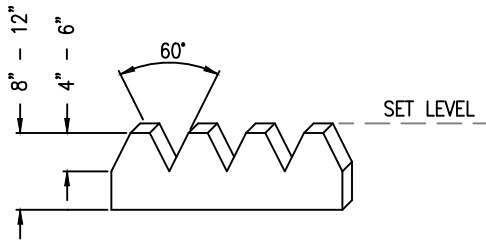

GRADE BOARD FLOW SPREADER DETAIL

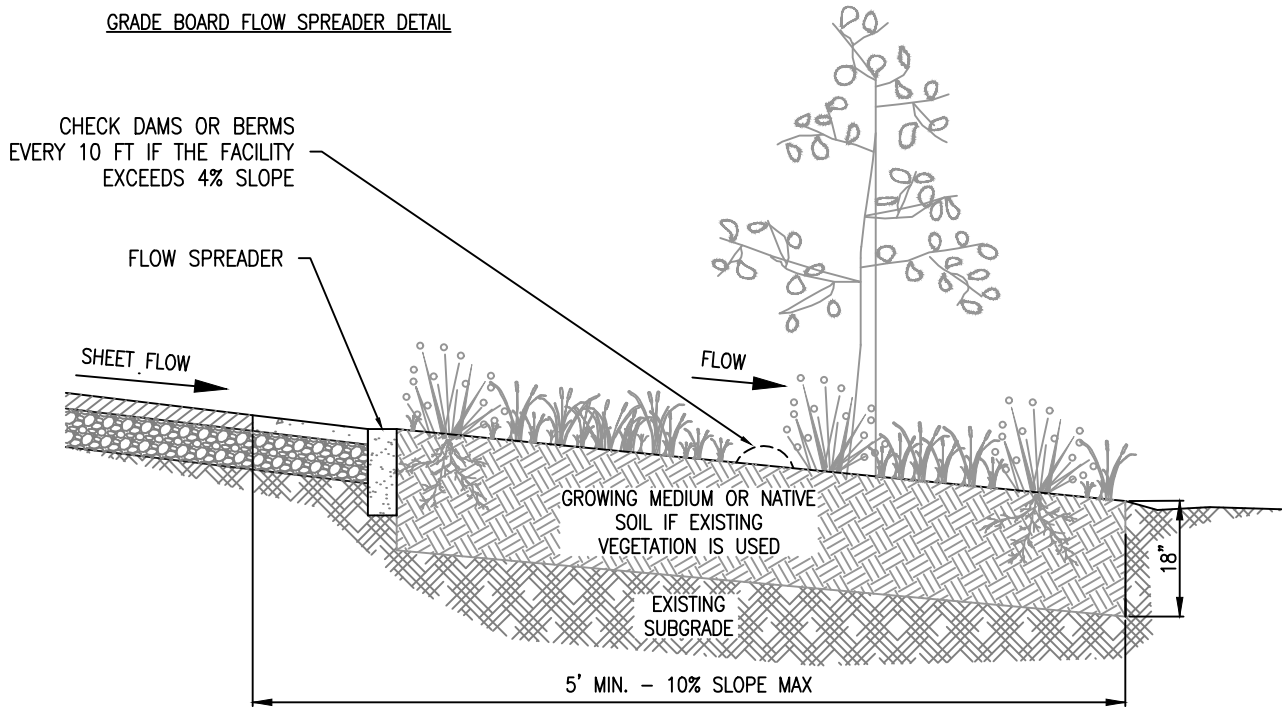

NOTES:

1. PROVIDE PROTECTION FROM ALL VEHICLE TRAFFIC, EQUIPMENT STAGING, AND FOOT TRAFFIC IN PROPOSED INFILTRATION AREAS PRIOR TO, DURING, AND AFTER CONSTRUCTION.
2. DIMENSIONS:
  - LENGTH: 5' MINIMUM
  - LONGITUDINAL SLOPE OF PLANTER: 0.5% TO 10%
3. FILTER STRIP MUST BE SETBACK A MINIMUM OF 5 FEET FROM PROPERTY LINE, 10 FEET FROM BUILDINGS, 50 FEET FROM WETLANDS, RIVERS, STREAMS AND CREEKS.
4. COLLECTION AND CONVEYANCE TO APPROVED DISCHARGE POINT MAY BE REQUIRED DEPENDING ON DESIGN AND SHALL BE SPECIFIED ON PLANS ACCORDING TO OLWS STANDARDS.
5. UNLESS EXISTING VEGETATED AREAS ARE USED FOR THE FILTER STRIP, GROWING MEDIUM SHALL BE USED WITHIN THE TOP 18". USE SAND/LOAM/COMPOST 3-WAY MIX OR APPROVED MIX THAT WILL SUPPORT HEALTHY PLANTS.
6. THE ENTIRE FILTER STRIP MUST HAVE 100% COVERAGE BY NATIVE GRASSES, NATIVE WILDFLOWER BLENDS, NATIVE GROUND COVERS, OR ANY COMBINATION THEREOF.
7. A GRADE BOARD OR SAND/GRAVEL TRENCH MAY BE REQUIRED AS A FLOW SPREADER TO DISPERSE THE RUNOFF EVENLY ACROSS THE FILTER STRIP TO PREVENT A POINT OF DISCHARGE. THE TOP OF THE LEVEL SPREADER MUST BE HORIZONTAL AND AT AN APPROPRIATE HEIGHT TO PROVIDE SHEETFLOW DIRECTLY TO THE SOIL WITHOUT SCOUR. LEVEL SPREADERS SHALL NOT HOLD A PERMANENT VOLUME OF RUNOFF. GRADE BOARDS CAN BE MADE OF ANY MATERIAL THAT WILL WITHSTAND WEATHER AND SOLAR DEGRADATION, TRENCHES USED AS LEVEL SPREADERS CAN BE FILLED WITH WASHED CRUSHED ROCK, PEA GRAVEL, OR SAND.
8. CHECK DAMS ARE REQUIRED FOR LONGITUDINAL SLOPES OVER 4% AND SHALL BE SPACED AT A MAXIMUM OF 2-FOOT ELEVATION INTERVALS. MAINTAIN 4-10 INCH DEEP ROCK CHECK DAMS AT DESIGN INTERVALS.

| NO. | REVISIONS | DATE | BY |
|-----|-----------|------|----|
| 1   |           |      |    |
| 2   |           |      |    |
| 3   |           |      |    |
| 4   |           |      |    |



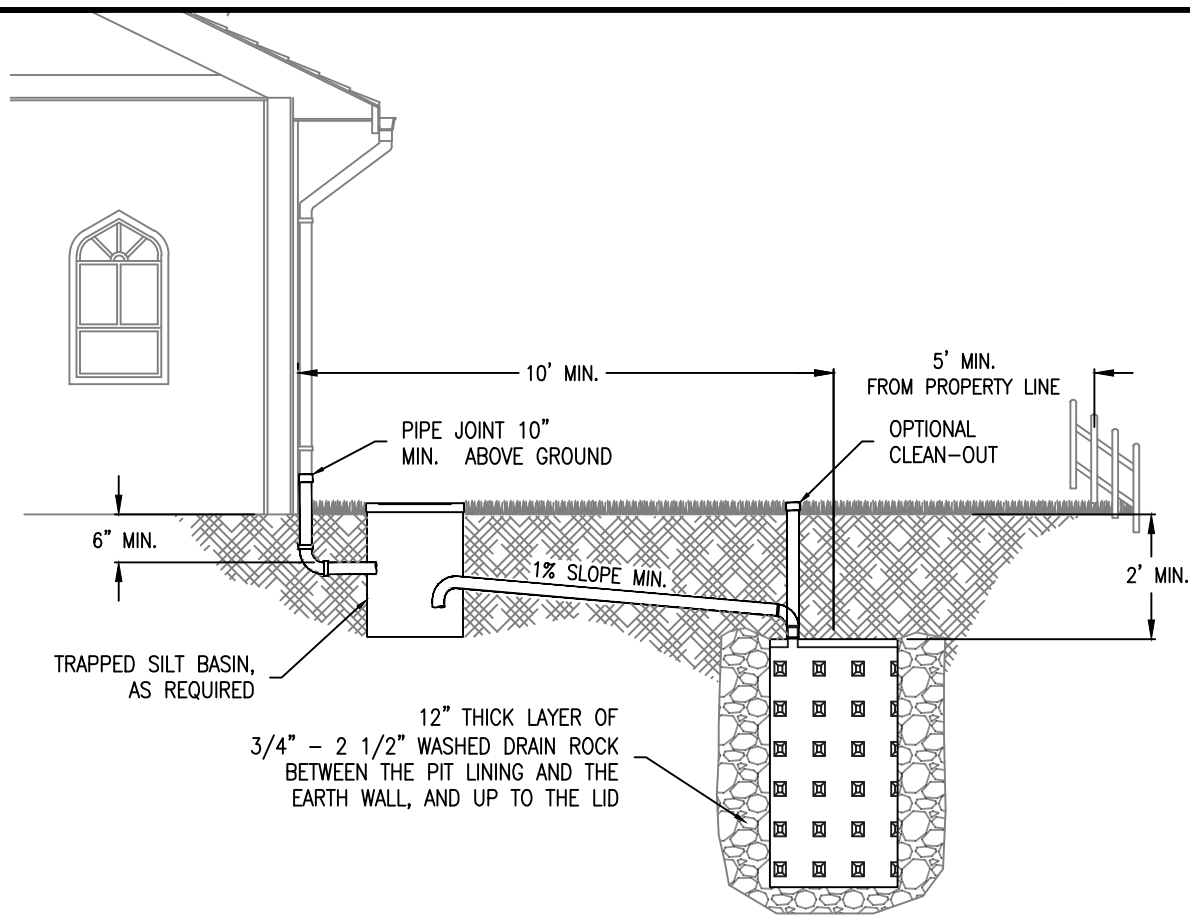

1. SIZING: SEE ADJACENT TABLE TO SIZE THE DRYWELL(S) BASED ON IMPERVIOUS AREA.
2. SITING CRITERIA: THE BASE OF THE DRYWELL MUST BE AT LEAST 5' ABOVE SEASONAL HIGH GROUNDWATER.
3. SETBACKS: MEASURED FROM THE CENTER, THE DRYWELL MUST BE 10' FROM FOUNDATIONS AND 5' FROM PROPERTY LINES EXCEPT NEXT TO THE RIGHT-OF-WAY WHERE NO SETBACK IS REQUIRED BETWEEN THE EDGE OF THE DRYWELL DRAIN ROCK AND THE PROPERTY LINE. THE FOUNDATION SETBACK IS 8" FOR PLASTIC MINI-DRYWELLS.
4. PIPING: CONFORM WITH OREGON PLUMBING SPECIALTY CODE (OPSC) REQUIREMENTS.
5. ACCESS: IN RESIDENTIAL SETTINGS, AN ACCESS CLEANOUT IS OPTIONAL BUT HIGHLY RECOMMENDED.
6. PRE-TREATMENT: A TRAPPED SILT BASIN SUCH AS A SUMPED CATCH BASIN IS REQUIRED EXCEPT FOR DRYWELLS MANAGING ROOF RUNOFF AND RUNOFF FROM PEDESTRIAN-ONLY AREAS.
7. THE TOP OF THE PERFORATED DRYWELL SECTIONS MUST BE LOWER THAN NEIGHBORING FOUNDATIONS.

| Drywell Depth  | Maximum Catchment Area Managed by One Drywell |              |
|--|---|--------------|
|  | 28" diameter                                  | 48" diameter |
| 5'   | 1000 sf                                       | 2500 sf      |
| 10'  | 2500 sf                                       | 4500 sf      |
| 15'  | 3500 sf                                       | 5000 sf      |
| 2x2 plastic mini-drywell (maximum of 2 drywells per catchment) | 500 sf  |              |

**CONSTRUCTION REQUIREMENTS**

SMEARING THE SOIL SURFACE DURING EXCAVATION CAN LIMIT INFILTRATION RATES. IF SMOOTH EXCAVATION TOOLS ARE USED, ROUGHEN THE SIDES AND BOTTOM OF THE EXCAVATION WITH A SHARP POINTED TOOL. REMOVE LOOSE MATERIAL FROM THE BOTTOM OF THE EXCAVATION.



**STORMWATER STANDARD DRAWING**

**DRYWELL**

| NO. | REVISIONS | DATE | BY |
|-----|-----------|------|----|
| 1   |           |      |    |
| 2   |           |      |    |
| 3   |           |      |    |
| 4   |           |      |    |

DRAWING NO.

**208**

DATE: 4/10/2024

SCALE: NTS

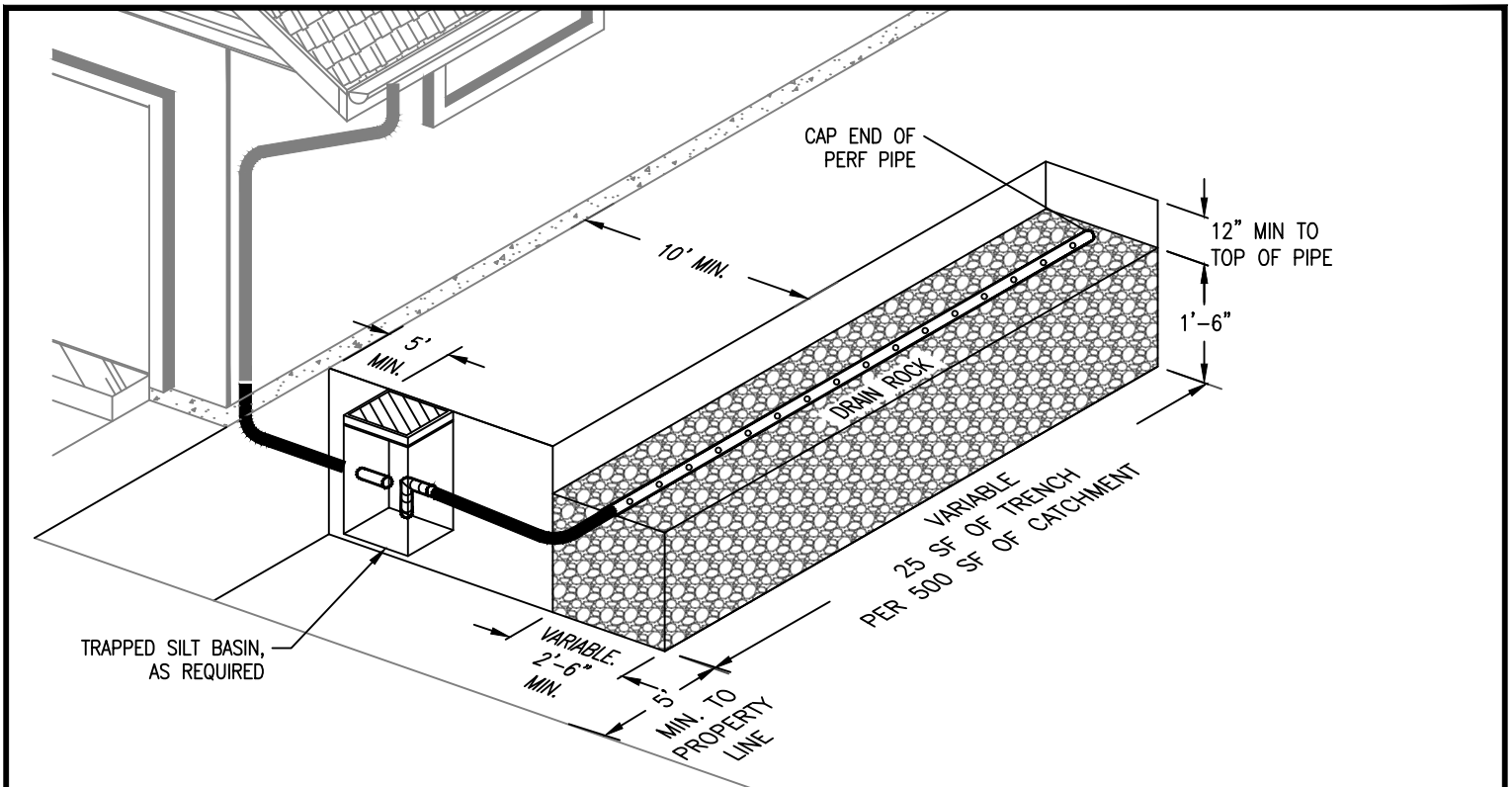

1. SITING CRITERIA: THE BASE OF THE SOAKAGE TRENCH MUST BE AT LEAST 5' ABOVE SEASONAL HIGH GROUNDWATER.
2. SIZING: 1'-6" TALL, 2'-6" WIDE MINIMUM. 25 SQUARE FEET OF TRENCH PER 500 SQUARE FEET OF CATCHMENT AREA.
3. SETBACKS: MEASURED FROM THE EDGE, THE SOAKAGE TRENCH MUST BE 10' FROM FOUNDATIONS AND 5' FROM PROPERTY LINES, EXCEPT NEXT TO THE RIGHT-OF-WAY.
4. PRE-TREATMENT: A TRAPPED SILT BASIN SUCH AS A SUMPED CATCH BASIN IS REQUIRED EXCEPT FOR SOAKAGE TRENCHES MANAGING ROOF RUNOFF AND RUNOFF FROM PEDESTRIAN-ONLY AREAS.
5. PIPING: CONFORM WITH OREGON PLUMBING SPECIALTY CODE (OPSC) REQUIREMENTS.
6. THE TOP OF THE SOAKAGE TRENCH MUST BE LOWER THAN FOUNDATIONS, INCLUDING BASEMENTS WITHIN 10 FEET OF THE SOAKAGE TRENCH.

SECTION

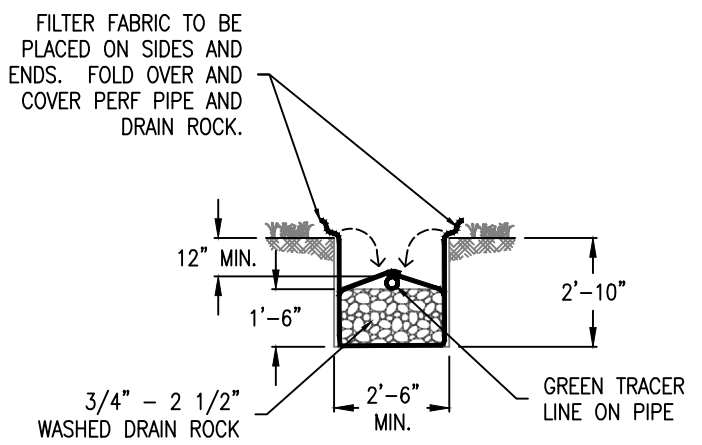

LINE TRENCH SIDES WITH PERMEABLE FILTER FABRIC AS SHOWN, ADD 18" OF DRAIN ROCK. PLACE PERF. PIPE AND COVER ALL.

CONSTRUCTION REQUIREMENTS

THE OUTLINE OF THE FACILITY MUST BE CLEARLY MARKED BEFORE SITE WORK BEGINS TO AVOID SOIL DISTURBANCE. USE OF HEAVY EQUIPMENT SHOULD BE MINIMIZED WITHIN 10 FEET OF SOAKAGE TRENCH AREAS. THE BOTTOM OF THE SOAKAGE TRENCH AND THE PERFORATED PIPE MUST BE LEVEL. CLAY CHECK DAMS MAY BE USED TO PREVENT WATER FROM COLLECTING NEAR THE DOWNSTREAM END. SMEARING THE SOIL SURFACE DURING EXCAVATION CAN POTENTIALLY LIMIT INFILTRATION RATES; IF SMOOTH EXCAVATION TOOLS ARE USED, ROUGHEN THE SIDES AND BOTTOM OF THE EXCAVATION WITH A SHARP POINTED TOOL. REMOVE LOOSE MATERIAL FROM THE BOTTOM OF THE EXCAVATION.



**STORMWATER STANDARD DRAWING**

SOAKAGE TRENCH

DRAWING NO.  
**209**

| NO. | REVISIONS | DATE | BY |
|-----|-----------|------|----|
| 1   |           |      |    |
| 2   |           |      |    |
| 3   |           |      |    |
| 4   |           |      |    |

DATE: 4/10/2024  
SCALE: NTS



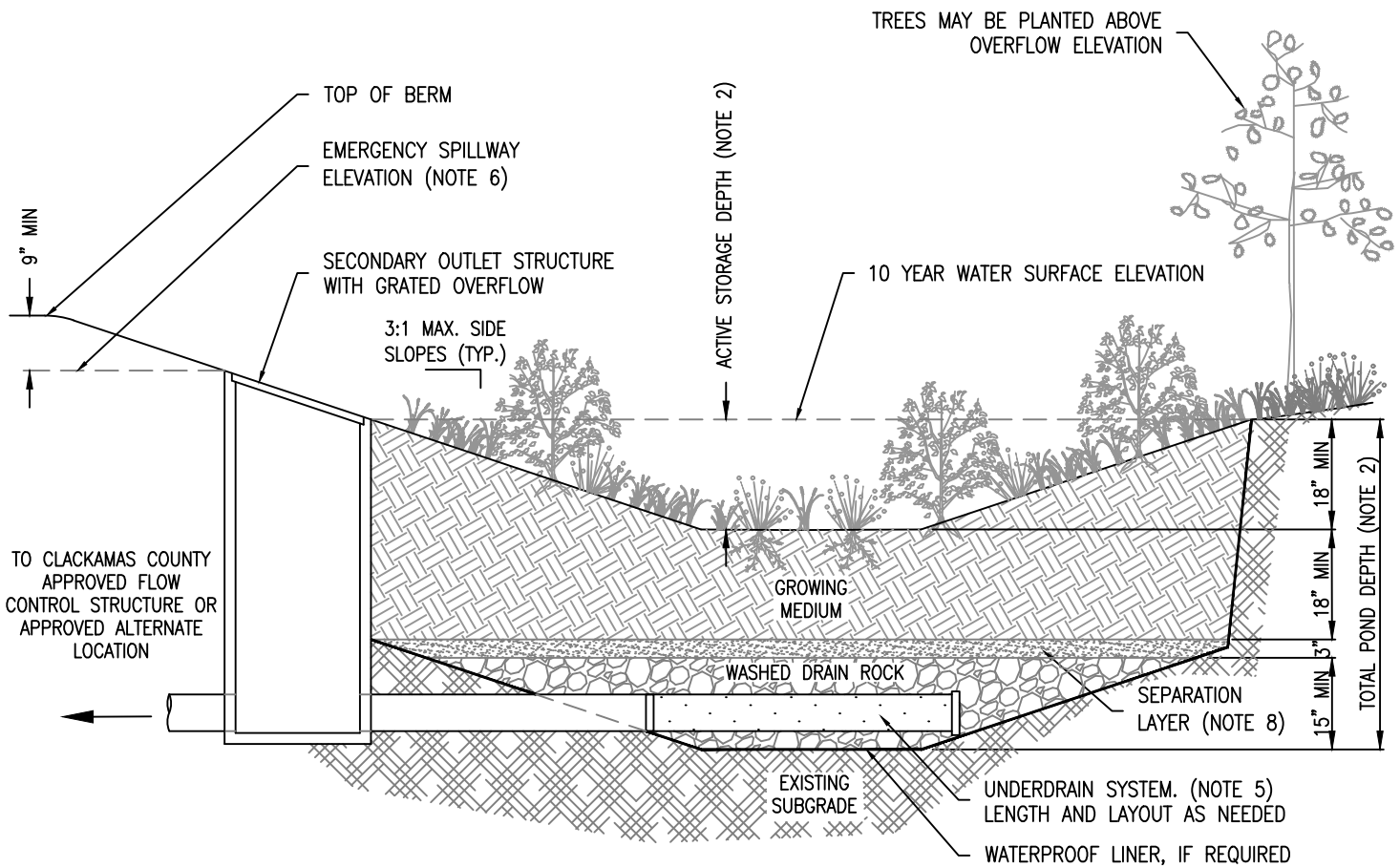

**NOTES:**

1. PROVIDE PROTECTION FROM ALL VEHICLE TRAFFIC, EQUIPMENT STAGING, AND FOOT TRAFFIC IN PROPOSED INFILTRATION AREAS PRIOR TO, DURING, AND AFTER CONSTRUCTION. UNLESS REQUIRED BY SITE CONDITIONS, UNLINED PONDS ARE PREFERRED TO ALLOW MAXIMUM INFILTRATION
2. DIMENSIONS:
  - ACTIVE STORAGE DEPTH (FROM TOP OF GROWING MEDIUM TO OVERFLOW ELEVATION): PER FACILITY SIZING MODEL
  - TOTAL POND DEPTH: 4" MINIMUM, PER FACILITY SIZING MODEL
  - BOTTOM SLOPE: 2.0% OR LESS OF
3. -SIDE SLOPE OF DETENTION POND: 3:1 MAXIMUM
4. DETENTION POND MUST BE SETBACK A MINIMUM OF 10 FEET FROM FOUNDATIONS AND 5 FEET FROM PROPERTY LINE.
5. PERFORATED UNDERDRAIN PIPING SHALL BE A MINIMUM OF 6" DIAMETER AND MATERIAL SHALL BE ABS SCH. 40, DUCTILE IRON, OR PVC SCH. 40. PIPING MUST HAVE 1% GRADE AND FOLLOW THE UNIFORM PLUMBING CODE. PVC PIPING NOT ALLOWED ABOVE GROUND.
6. EMERGENCY SPILLWAY TO BE SIZED TO CONVEY THE 100 YEAR DESIGN STORM. PROVIDE 6" MINIMUM FREEBOARD ABOVE THE 100-YEAR DESIGN STORM.
7. DRAIN ROCK SIZE: 1 1/2" - 3/4" WASHED WITH 15" DEPTH.
8. SEPARATION BETWEEN DRAIN ROCK AND GROWING MEDIUM SHALL BE A 3" LAYER OF 3/4" - 1/4" OPEN GRADED AGGREGATE.
9. GROWING MEDIUM WILL BE A MINIMUM 18" DEPTH.
10. VEGETATION WILL FOLLOW THE LANDSCAPE PLANS.
11. WATERPROOF LINE, IF REQUIRED, SHALL BE 30 MIL PVC OR EQUIVALENT FOR DETENTION POND.
12. SEASONAL HIGH GROUNDWATER SEPARATION DISTANCE AS REQUIRED.

**DETENTION POND**

| NO. | REVISIONS | DATE | BY |
|-----|-----------|------|----|
| 1   |           |      |    |
| 2   |           |      |    |
| 3   |           |      |    |
| 4   |           |      |    |

DRAWING NO.

**210**

DATE: 4/10/2024

SCALE: NTS

# OAK LODGE

WATER SERVICES

## SEWER SYSTEM STANDARD DRAWING INDEX

STANDARD DRAWINGS

|     |  |
|-----|--|
| 300 | INDEX  |
| 301 | CONSTRUCTION NOTES                               |
| 302 | TYPICAL TRENCH DETAIL                            |
| 303 | MANHOLE-TYPICAL                                  |
| 304 | MANHOLE – FLAT TOP                               |
| 305 | POURED-IN-PLACE SADDLE MANHOLE BASE SHEET 1 OF 2 |
| 306 | POURED-IN-PLACE SADDLE MANHOLE BASE SHEET 2 OF 2 |
| 307 | PRECAST MANHOLE BASE                             |
| 308 | FRAME & COVER (STANDARD)                         |
| 309 | FRAME & COVER (SUBURBAN)                         |
| 310 | FRAME & COVER (SECURE / WATERTIGHT)              |
| 320 | SERVICE CONNECTION TO MANHOLE                    |
| 321 | SERVICE CONNECTION TO MANHOLE – INSIDE DROP      |
| 322 | MANHOLE – OUTSIDE DROP                           |
| 323 | SERVICE LATERAL                                  |
| 324 | HOUSE / PUBLIC SEWER MAIN CONNECTION –TYPICAL    |
| 325 | 6” TAP ON AN EXISTING 8” MAIN LINE               |

| NO. | REVISIONS | DATE | BY |
|-----|-----------|------|----|
| 1   |           |      |    |
| 2   |           |      |    |
| 3   |           |      |    |
| 4   |           |      |    |

NOTES:

1. CONSTRUCTION OF IMPROVEMENTS SHALL BE IN ACCORDANCE WITH OAK LODGE WATER SERVICES (OLWS a.k.a. DISTRICT) DEVELOPER EXTENSION AGREEMENT (as applicable), DISTRICT STANDARD DETAILS AND THE OREGON STANDARD SPECIFICATIONS FOR CONSTRUCTION, MOST CURRENT EDITION, AS ISSUED BY THE OR. STATE DEPT. OF TRANSPORTATION.
2. A PRE-CONSTRUCTION CONFERENCE IS REQUIRED PRIOR TO CONSTRUCTION AND 48 HOURS ADVANCE NOTIFICATION OF THE LOCAL MUNICIPALITY, OLWS AND ALL AFFECTED UTILITY COMPANIES PRIOR TO THE ACTUAL START OF WORK.
3. THE CONTRACTOR SHALL BE RESPONSIBLE FOR COMPLYING WITH THE PROVISIONS OF THE ROAD OPENING PERMIT AS ISSUED BY CLACKAMAS COUNTY.
4. LOCATIONS OF EXISTING UTILITIES SHOWN ON THE PLANS ARE APPROXIMATE. IT SHALL BE THE CONTRACTOR'S RESPONSIBILITY TO VERIFY, LOCATE AND PROTECT ALL UTILITIES WITHIN THE PROJECT AREA. THE CONTRACTOR SHALL BE RESPONSIBLE FOR REPLACING OR REPAIRING ANY UTILITIES DAMAGED DURING CONSTRUCTION. SHOW THESE UTILITIES ON THE AS-BUILTS. IF A UTILITY IS DAMAGED, THE CONTRACTOR SHALL NOTIFY THE AFFECTED UTILITY COMPANY IMMEDIATELY.
5. SANITARY MAIN TRENCH SECTION AND ALL EXCAVATED AREAS SHALL BE BACKFILLED AND COMPACTED IN ACCORDANCE WITH THE STANDARD DETAILS, THE ROAD OPENING PERMIT, AND WITH SECTION 01140.40 OF THE STANDARD SPECIFICATIONS. COMPACTION TESTING SHALL BE REQUIRED DURING BACKFILLING OPERATIONS WITHIN ALL ROADWAYS AND AT THE DISCRETION OF THE DISTRICT. IF TRENCH BACKFILL DOES NOT MEET COMPACTION REQUIREMENTS, CONTRACTOR SHALL EXCAVATE, RECOMPACT AND RETEST MATERIAL AT CONTRACTOR'S EXPENSE.
6. RESTORATION OF DAMAGED ROAD SURFACING SHALL BE IN ACCORDANCE WITH CLACKAMAS COUNTY REQUIREMENTS. ALL OTHER AREAS SHALL BE RESTORED TO ORIGINAL CONDITION OR AS DIRECTED BY THE DISTRICT. THIS INCLUDES SHOULDERS, LANDSCAPING, WALLS, DRIVEWAYS, FENCES AND OTHER IMPROVEMENTS.
7. POLYVINYL CHLORIDE PIPE (PVC) SHALL CONFORM TO THE REQUIREMENTS OF ASTM D-3034, SDR 35, AND JOINT TYPE SHALL BE ELASTOMERIC GASKET CONFORMING TO ASTM D-3212.
8. MANHOLES TO BE PRECAST CONCRETE SECTIONS WITH MINIMUM INSIDE DIAMETER OF 48-INCHES, CONFORMING TO THE REQUIREMENTS OF ASTM C-478, EXCEPT AS NOTED ON THE PLANS.
9. POLYVINYL CHLORIDE PIPE (PVC) SHALL BE INSTALLED IN ACCORDANCE WITH THE MANUFACTURERS' RECOMMENDATIONS. PVC SEWER PIPE SHALL BE CONNECTED TO CONCRETE MANHOLES BY MEANS OF A KOR-N-SEAL BOOT (OR EQUIVALENT). SAND COLLARS WILL NOT BE ACCEPTED.
10. AFTER THE CONTRACTOR HAS BACKFILLED THE PIPE ZONE OF THE TRENCH AS REQUIRED, HE SHALL THEN BACKFILL THE BALANCE OF THE TRENCH, WITH THE TYPE OF BACKFILL SPECIFIED, IN ONE FOOT (1') LAYERS, MECHANICALLY COMPACTING EACH LAYER TO 95% OF MAXIMUM DENSITY IN ROADWAYS AND 85% TO 90% IN ALL OTHER AREAS. MAXIMUM RELATIVE DENSITY SHALL BE DETERMINED PER AASHTO T-180. IN PLACE, DENSITY SHALL BE DETERMINED PER AASHTO T-191, T-205 OR T-238. ANY SUBSEQUENT SETTLEMENT OF THE TRENCH OR DITCH DURING THE GUARANTEE PERIOD SHALL BE CONSIDERED TO BE THE RESULT OF IMPROPER COMPACTION AND SHALL BE PROMPTLY CORRECTED BY THE CONTRACTOR AT NO EXPENSE TO THE DISTRICT OR THE OWNER.
11. SANITARY SEWER PIPE AND APPURTENANCES SHALL BE TESTED FOR LEAKAGE IN ACCORDANCE WITH OLWS STANDARDS. LEAKAGE TESTS INCLUDE AN AIR TEST OF THE SEWER MAINS AND SERVICE CONNECTIONS AND VACUUM TEST OF THE MANHOLES. ANY PORTION OF THE SEWER WHICH FAILS TO PASS THESE TESTS SHALL BE EXCAVATED, REPAIRED OR REALIGNED, AND RETESTED. IN ADDITION TO LEAKAGE TESTING, SANITARY SEWERS CONSTRUCTED OF PVC SEWER PIPE SHALL BE DEFLECTION TESTED AFTER THE TRENCH BACKFILL AND COMPACTION HAS BEEN COMPLETED. THE TEST SHALL BE CONDUCTED BY PULLING AN APPROVED SOLID POINTED MANDREL 95% OF THE INSIDE DIAMETER THROUGH THE PIPELINE ON A MANHOLE TO MANHOLE BASIS. IN ADDITION, ALL MAIN LINES MUST BE VIDEO INSPECTED, AND A VIDEO RECORD ON A FLASH DRIVE MUST BE SUBMITTED TO OLWS. NOTE THAT ALL TESTS AND THE VIDEO INSPECTIONS MUST BE PERFORMED IN THE PRESENCE OF THE OLWS INSPECTOR.
12. UNLESS OTHERWISE SPECIFIED ON THE PLANS OR DIRECTED BY THE ENGINEER, EACH SERVICE CONNECTION SHALL BE LAID IN A SEPARATE TRENCH ON A STRAIGHT LINE AND GRADIENT FROM THE TEE TO THE END OF THE SERVICE CONNECTION. THE SERVICES CONNECTION SHALL BE INSTALLED PERPENDICULAR TO THE MAIN LINE AND MUST HAVE A MINIMUM OF 5 FEET OF COVER IN ALL PARTS OF THE ROAD RIGHT OF WAY AND UTILITY EASEMENT. NO SERVICE CONNECTION SHALL BE LAID ON A SLOPE OF LESS THAN TWO PERCENT, UNLESS OTHERWISE DIRECTED BY THE ENGINEER OR SHOWN ON THE PLANS. THE ENGINEER WILL PROVIDE A CUT STAKE AT THE TERMINAL POINT OF EACH SERVICE CONNECTION. THE CONTRACTOR WILL USE A PIPE LASER TO ACHIEVE CORRECT GRADE AND ALIGNMENT. EACH SERVICE CONNECTION SHALL BE PLUGGED WITH A RUBBER RING PLUG. A 2 X 4 MARKER PAINTED GREEN SHALL BE PLACED AT THE END OF EACH SERVICE CONNECTION, AND SHALL EXTEND FROM THE END OF THE PIPE TO A POINT THREE FEET (3') OR MORE ABOVE THE SURFACE OF THE GROUND. A DETECTABLE GREEN MAGNETIC TAPE WITH THE WORD "SEWER" AT REGULAR INTERVALS SHALL BE PLACED ALONG THE SERVICE CONNECTION FROM THE MAINLINE TEE TO THE GROUND SURFACE. EACH SERVICE CONNECTION MUST HAVE A CLEAN OUT WITH A TRAFFIC-RATED BOX LOCATED AT THE EDGE OF THE ROAD RIGHT-OF-WAY OR UTILITY EASEMENT.
13. IN EASEMENT AREAS ALL MANHOLES SHALL HAVE TAMPER-PROOF LIDS PER OLWS SPECIFICATIONS, OR APPROVED EQUAL. IN EASEMENT AREAS MANHOLE FRAMES SHALL BE INSTALLED A MINIMUM OF 6" ABOVE THE SURROUNDING GRADE.
14. THE CONTRACTOR SHALL AT ALL TIMES PROVIDE AND MAINTAIN AMPLE MEANS AND DEVICES TO REMOVE AND DISPOSE OF ALL WATER ENTERING THE TRENCH EXCAVATION DURING THE PROCESS OF LAYING THE PIPE. WATER AND DEBRIS SHALL NOT ENTER INTO THE DISTRICT'S SEWER SYSTEM. WATER AND DEBRIS SHALL BE DISPOSED OF IN AN APPROVED MANNER.
15. THERE MUST BE A MINIMUM OF 5 FEET OF CLEAR HORIZONTAL SEPARATION BETWEEN A WATER MAIN AND A SANITARY LINE. THERE MUST BE A MINIMUM OF 5 FEET OF CLEAR HORIZONTAL SEPARATION BETWEEN A WATER SERVICE AND A SANITARY LINE.



**SANITARY SYSTEM STANDARD DRAWING**

**SANITARY SEWER  
CONSTRUCTION NOTES**

| NO. | REVISIONS                               | DATE       | BY  |
|-----|---|------------|-----|
| 1   | TITLE and NOTES 5, 8, 9, 11, 12, 13, 15 | 1/9/2019   | HSO |
| 2   | NOTE 15, SPACING REQ                    | 12/14/2020 | HSO |
| 3   | NOTES 11, 13                            | 3/5/2024   | TAP |
| 4   |   |            |     |

DRAWING NO.

**301**

DATE: 9/12/2017

SCALE: NTS

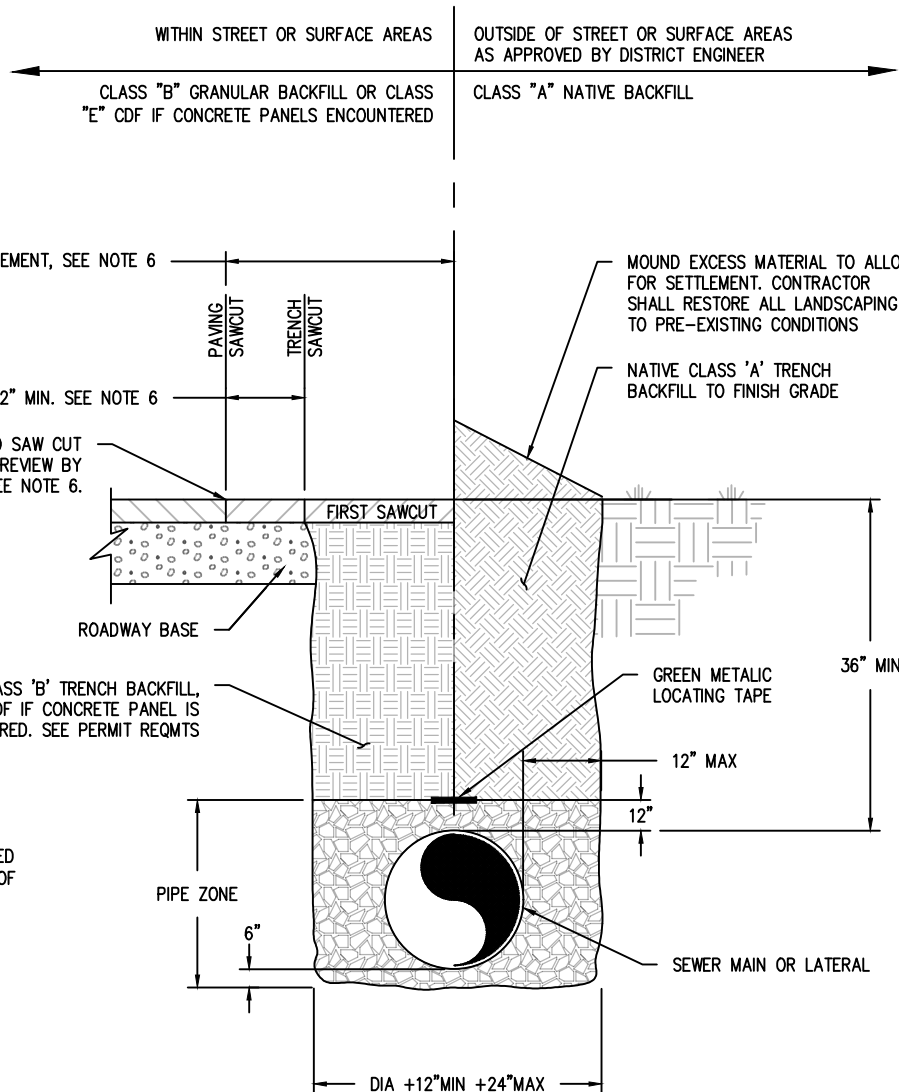

**NOTES:**

1. PIPE ZONE MATERIAL SHALL BE 3/4"-0" CRUSHED ROCK GRANULAR BACKFILL COMPACTED TO 95% OF AASHTO T-99.
2. CLASS "A" NATIVE BACKFILL MAY ONLY BE USED OUTSIDE OF PAVED AREAS AND REQUIRES OLWS APPROVAL. BACKFILL SHALL BE COMPACTED TO 90% OF AASHTO T-99 IN LIFTS NOT EXCEEDING 18" (LOOSE MEASURE).
3. CLASS "B" 3/4"-0" CRUSHED ROCK GRANULAR BACKFILL SHALL BE USED WITHIN PAVED AREAS. BACKFILL SHALL BE COMPACTED TO 95% OF AASHTO T-99.
4. BACKFILL SHALL BE PLACED AND COMPACTED IN A MAXIMUM OF 24-INCH LIFTS. COMPACTION TESTING REQUIRED AT A FREQUENCY OF 1 TEST EVERY 100 FEET OF TRENCH.
5. RESURFACING TO BE MINIMUM 4 INCHES 1/2-INCH LEVEL 2 HMAC (PG 64-22) OR MATCH EXISTING, WHICHEVER IS GREATER.
6. SAWCUT WIDTH AND AC PAVEMENT REPLACEMENT SHALL BE PER APPLICABLE JURISDICTIONAL REQUIREMENTS. SAWCUT CLEAN EDGE FOR AC PAVEMENT REPLACEMENT. SAND SEAL JOINT.
7. PROVIDE CLASS "E" CDF BACKFILL FOR ALL TRENCH CROSSINGS LOCATED IN VEHICLE TRAVEL LANES OF ARTERIAL & COLLECTOR STREETS, OR WHERE CONCRETE PANELS ARE ENCOUNTERED. IF THESE SPECIFICATIONS CONFLICT WITH THE SPECIFICATIONS OF ANOTHER APPLICABLE JURISDICTION, THE MORE STRINGENT SPECIFICATION SHALL GOVERN.

| NO. | REVISIONS | DATE | BY |
|-----|-----------|------|----|
| 1   |           |      |    |
| 2   |           |      |    |
| 3   |           |      |    |
| 4   |           |      |    |

LOCATE FRAME AND COVER OVER LEDGE OF AT LEAST 12" IN WIDTH

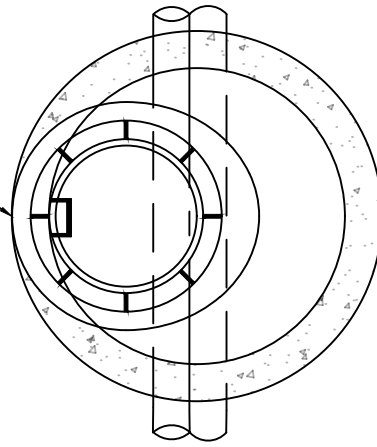

PLAN

MANHOLE FRAME MUST BE FLUSH WITH ROADWAY WITHOUT THE USE OF PAVING RINGS, SEE NOTE 5 FOR ADDITIONAL INFORMATION

NON-SHRINK GROUT REQUIRED AT ALL JOINTS WITH FRAME, RINGS, AND BARREL SECTIONS

POLYETHYLENE STEPS W/ IRON REINFORCEMENT, 8"x12" WIDE, 2" DROP. LOCATE FIRST STEP OVER SHELF AND INSTALL W/ 3" IMBED AT 12" O.C., TYP., U.N.O., SEE NOTE 6 FOR ADDITIONAL INFORMATION

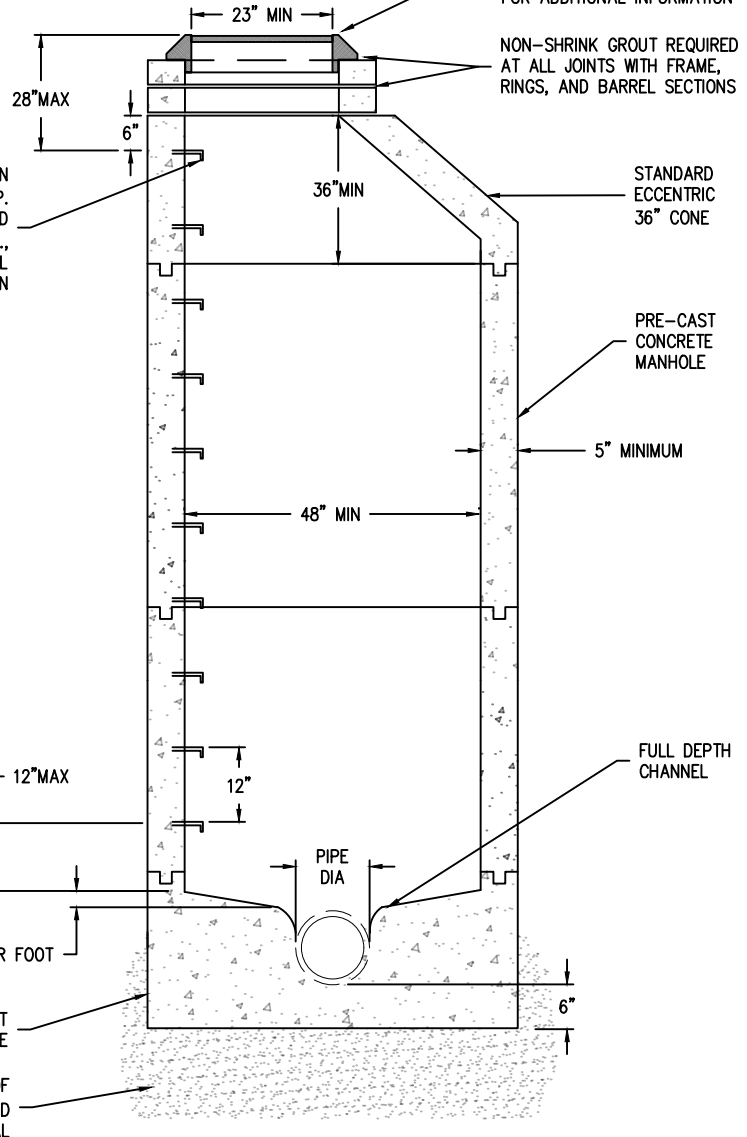

SECTION

NOTES:

1. MANHOLE LID TO BE FLUSH WITH ROADWAY OR 6" ABOVE FINISH GRADE IN EASEMENTS UNLESS OTHERWISE SPECIFIED.
2. SHELF SHALL NOT BE BELOW THE SPRING LINE OF THE PIPE.
3. STRUCTURE OPENINGS TO BE PRE-CAST OR CORE DRILLED ONLY.
4. ALL PRE-CAST MANHOLE SECTIONS SHALL CONFORM TO THE REQUIREMENTS OF ASTM C-478.
5. ALL JOINTS AND RUBBER GASKETS SHALL CONFORM TO THE REQUIREMENTS OF ASTM C-443.
6. STEPS SHALL CONFORM TO THE REQUIREMENTS OF ASTM C-478. MANHOLE STEPS MUST BE TIGHT AND FIRMLY EMBEDDED. ALL STEPS WITHIN A MANHOLE SHALL BE OF THE SAME DESIGN, TYPE, AND (MIXING OF UNMATCHED STEPS IS NOT PERMITTED). MANHOLES UNDER 3' DEEP DO NOT REQUIRE STEPS.
7. ALL PIPE CONNECTIONS TO MANHOLE SHALL BE WATERTIGHT.
8. CHANNEL MUST HAVE A MINIMUM OF 0.2' DROP BETWEEN INLET AND OUTLET.
9. CHANNELS MUST BE ABLE TO PASS A 7"x30" CYLINDER INTO PIPES.

| NO. | REVISIONS | DATE | BY |
|-----|-----------|------|----|
| 1   |           |      |    |
| 2   |           |      |    |
| 3   |           |      |    |
| 4   |           |      |    |

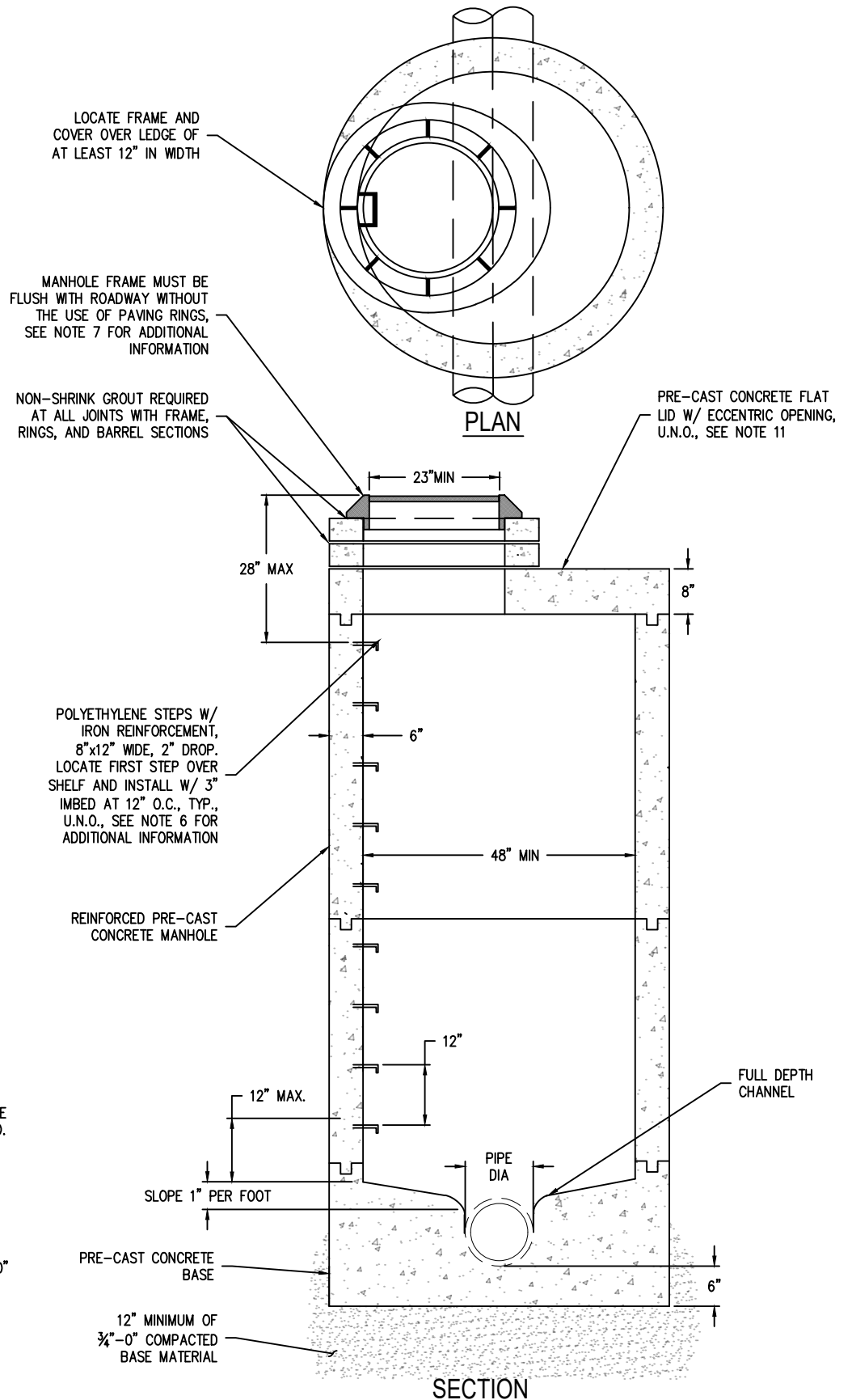

**NOTES:**

1. FLAT TOP IS REQUIRED WHEN HEIGHT FROM SHELF TO TOP OF LAST BARREL SECTION IS 4' OR LESS.
2. SHELF SHALL NOT BE BELOW THE SPRING LINE OF THE PIPE.
3. STRUCTURE OPENINGS TO BE PRE-CAST OR CORE DRILLED ONLY.
4. ALL PRE-CAST MANHOLE SECTIONS SHALL CONFORM TO THE REQUIREMENTS OF ASTM C-478.
5. ALL JOINTS AND RUBBER GASKETS SHALL CONFORM TO THE REQUIREMENTS OF ASTM C-443.
6. STEPS SHALL CONFORM TO THE REQUIREMENTS OF ASTM C-478. MANHOLE STEPS MUST BE TIGHT AND FIRMLY EMBEDDED. ALL STEPS WITHIN A MANHOLE SHALL BE OF THE SAME DESIGN, TYPE, AND (MIXING OF UNMATCHED STEPS IS NOT PERMITTED.) MANHOLES UNDER 3' DEEP DO NOT REQUIRE STEPS.
7. MANHOLE LID TO BE 6" ABOVE FINISH GRADE IN EASEMENTS UNLESS OTHERWISE SPECIFIED.
8. ALL PIPE CONNECTIONS TO MANHOLE SHALL BE WATERTIGHT.
9. CHANNEL MUST HAVE A MINIMUM OF 0.2' DROP BETWEEN INLET AND OUTLET.
10. CHANNELS MUST BE ABLE TO PASS A 7"x30" CYLINDER INTO PIPES.
11. CONCENTRIC LID REQUIRED WHEN HEIGHT FROM SHELF TO TOP OF LAST BARREL SECTION IS 3' OR LESS.

POLYETHYLENE STEPS W/ IRON REINFORCEMENT, 8"x12" WIDE, 2" DROP. LOCATE FIRST STEP OVER SHELF AND INSTALL W/ 3" IMBED AT 12" O.C., TYP., U.N.O., SEE NOTE 6 FOR ADDITIONAL INFORMATION

REINFORCED PRE-CAST CONCRETE MANHOLE

PRE-CAST CONCRETE BASE

12" MINIMUM OF 3/4"-0" COMPACTED BASE MATERIAL

| NO. | REVISIONS | DATE | BY |
|-----|-----------|------|----|
| 1   |           |      |    |
| 2   |           |      |    |
| 3   |           |      |    |
| 4   |           |      |    |



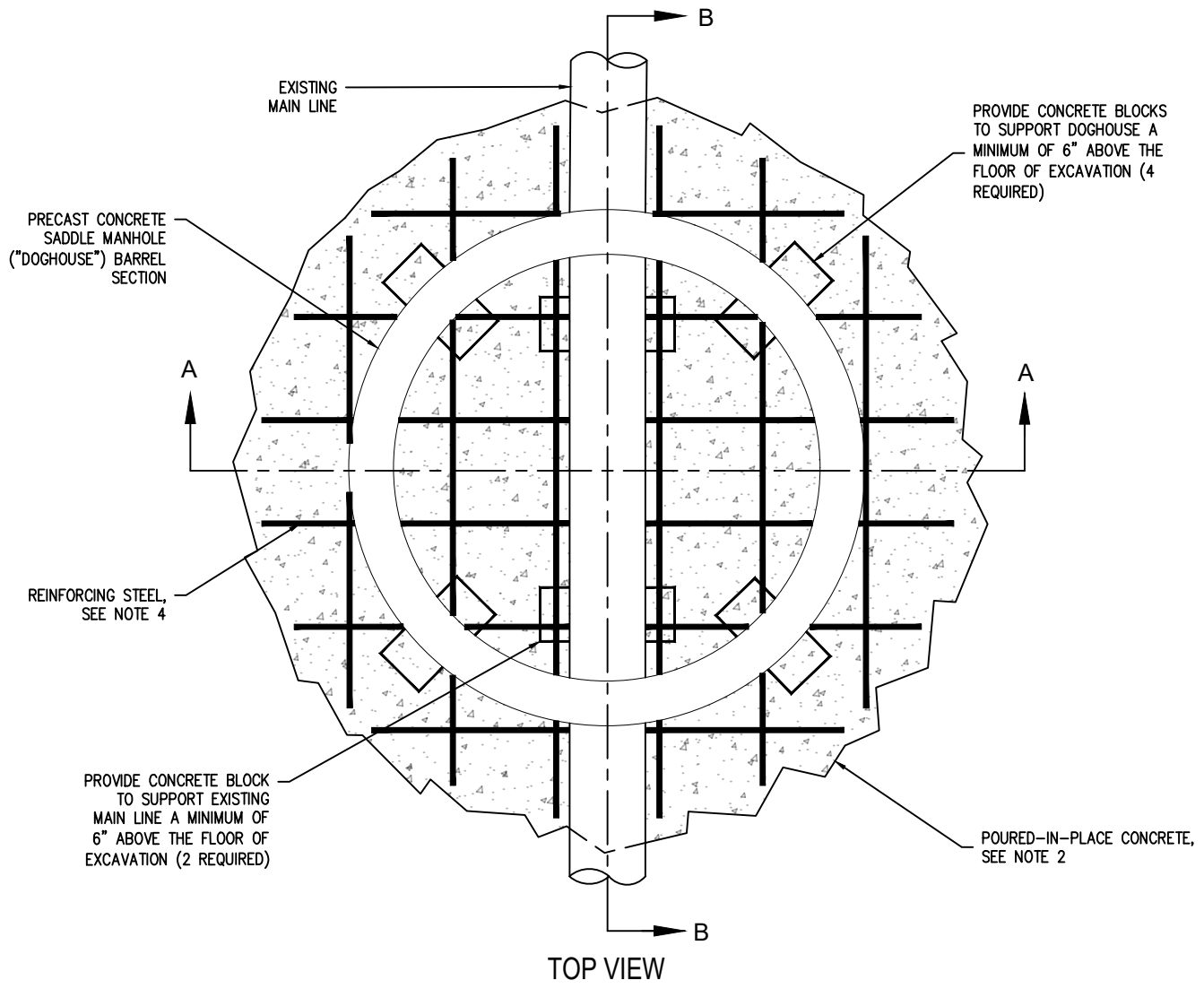

TOP VIEW

1. POURED-IN-PLACE BASE IS ALLOWED ONLY FOR NEW MANHOLES CONSTRUCTED OVER EXISTING MAIN LINES. ALL OTHER MANHOLE BASES MUST BE PRE-CAST UNITS.
2. A MINIMUM OF 6" OF POURED-IN-PLACE CONCRETE MUST BE PROVIDED UNDER ALL PARTS OF THE EXISTING MAIN AND UNDER THE BOTTOM OF THE DOGHOUSE. THIS CONCRETE MUST EXTEND 12" OUTSIDE OF THE MANHOLE WALL IN ALL DIRECTIONS AND MUST EXTEND 6" ABOVE THE BOTTOM OF THE DOGHOUSE BOTH INSIDE AND OUTSIDE THE MANHOLE.
3. THE POURED CONCRETE MUST HAVE A MINIMUM OF 5 SACKS OF CEMENT PER CUBIC YARD AND MEET A MINIMUM 3000 psi COMPRESSION TEST AFTER 28 DAYS.
4. REINFORCING SHALL BE #5 REBAR AT 12" ON CENTER, EACH WAY, OR TWO (2) MATS OF 6 x 6 x 10 GAUGE SHEET MESH. CENTER REINFORCING WITHIN POURED-IN-PLACE CONCRETE SLAB WITH 3" COVER.
5. THE DIAMETER OF THE PRE-CAST OPENINGS IN THE DOGHOUSE CAN BE NO MORE THAN 6" GREATER THAN THE OUTSIDE DIAMETER OF THE EXISTING MAIN. THE DOGHOUSE SHALL BE PLACED SO THAT THE EXISTING MAIN IS CENTERED IN THE OPENING.
6. IF THE EXISTING MAIN IS PVC OR HDPE, SANDED COLLARS MUST BE INSTALLED ON THE MAIN AND CENTERED IN THE PRE-CAST OPENINGS.
7. PIPE CONNECTIONS MUST BE MADE TO THE PRE-CAST OR CORED HOLES WITH KOR-N-SEAL BOOTS OR EQUIVALENT WHENEVER POSSIBLE. SANDED COLLARS WILL BE ACCEPTED ONLY WHEN THEY ARE POURED INTO THE MANHOLE BASE.
8. THE ANNULAR SPACES BETWEEN THE EXISTING MAIN AND THE PRE-CAST OPENINGS MUST BE FILLED WITH CONCRETE WHICH EXTENDS WELL BEYOND THE OPENINGS IN ALL DIRECTIONS, BOTH INSIDE AND OUTSIDE OF THE MANHOLE.
9. NOTE THAT THE TOP OF EXISTING MAIN IS NOT TO BE "CUT OUT" UNTIL A MANHOLE VACUUM TEST HAS BEEN WITNESSED AND APPROVED BY THE OLWS INSPECTOR. THE OPENING IN THE PIPE IS TO BE NEATLY FINISHED AND SHALL BE SIZED TO ALLOW A 7" x 30" CYLINDER TO PASS INTO ALL PIPES.

| NO. | REVISIONS | DATE | BY |
|-----|-----------|------|----|
| 1   |           |      |    |
| 2   |           |      |    |
| 3   |           |      |    |
| 4   |           |      |    |

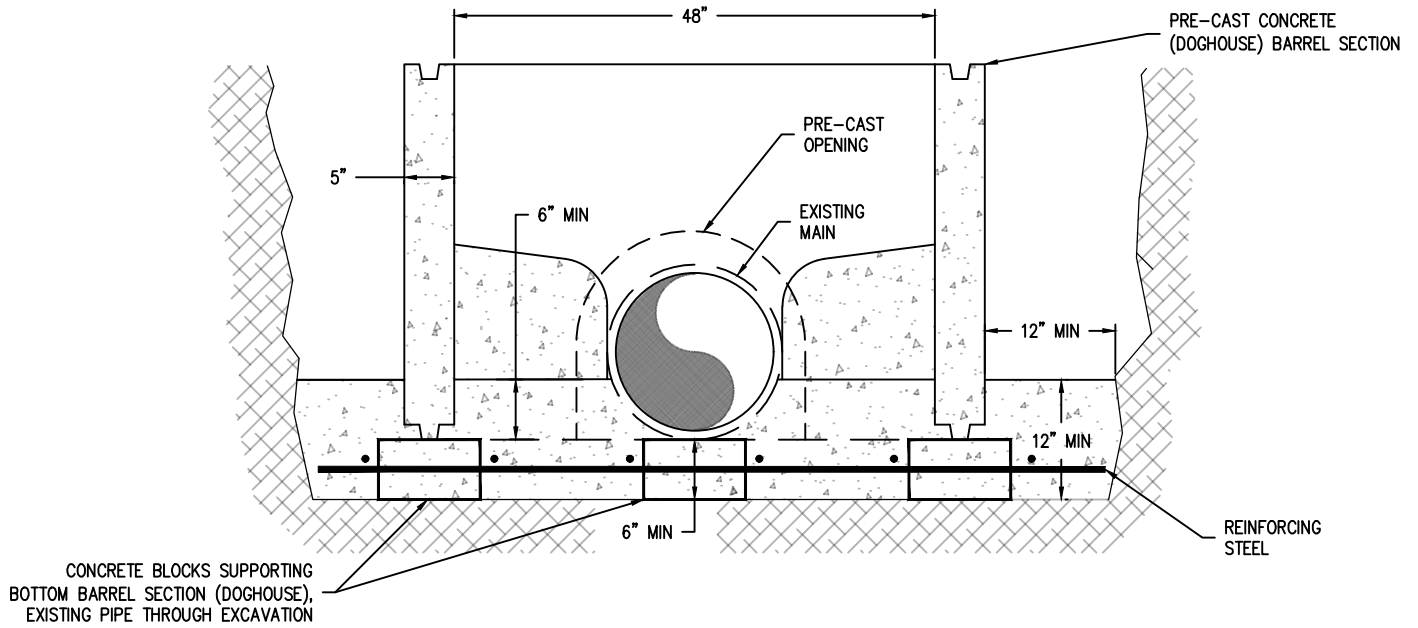

**SECTION A-A**

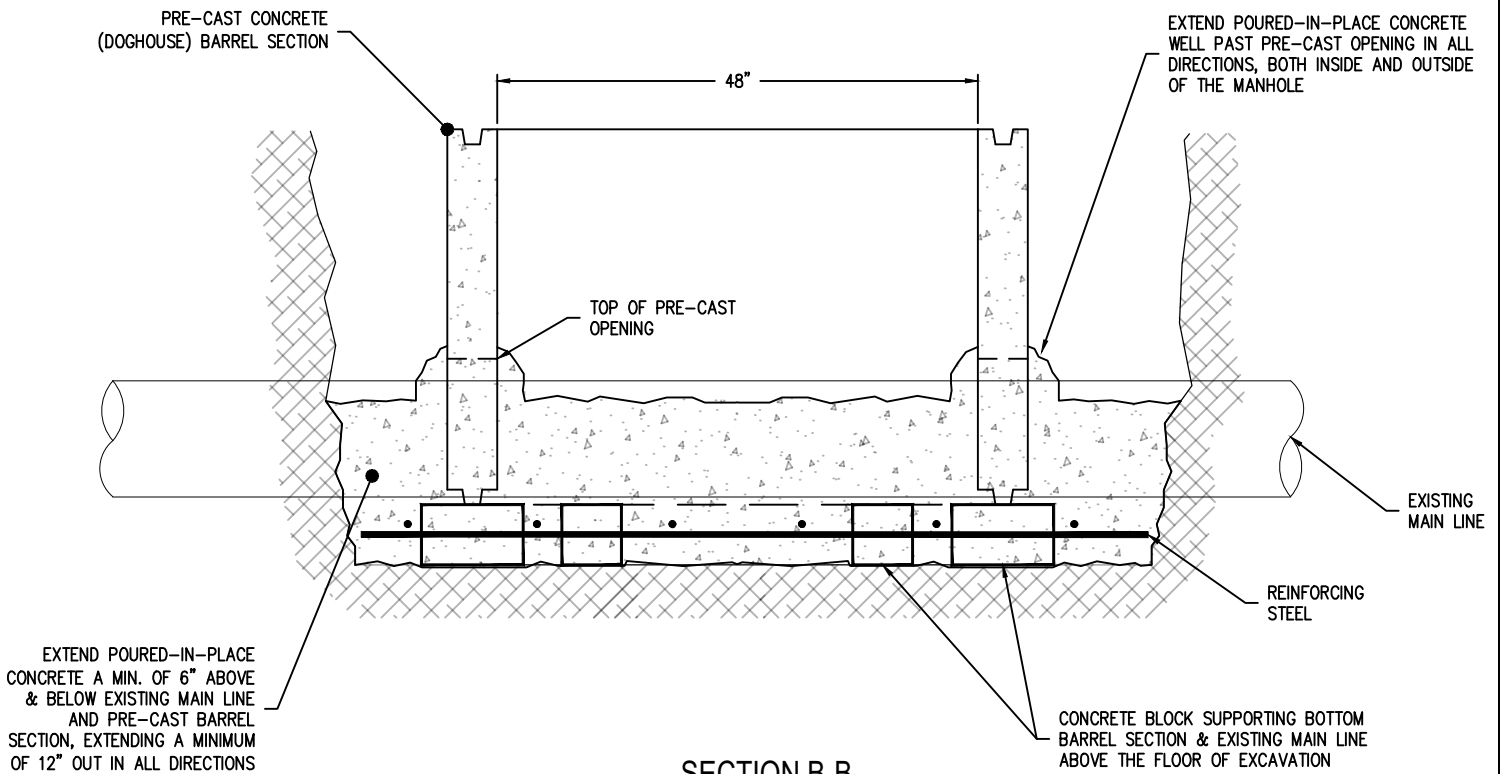

**SECTION B-B**

| NO. | REVISIONS | DATE | BY |
|-----|-----------|------|----|
| 1   |           |      |    |
| 2   |           |      |    |
| 3   |           |      |    |
| 4   |           |      |    |



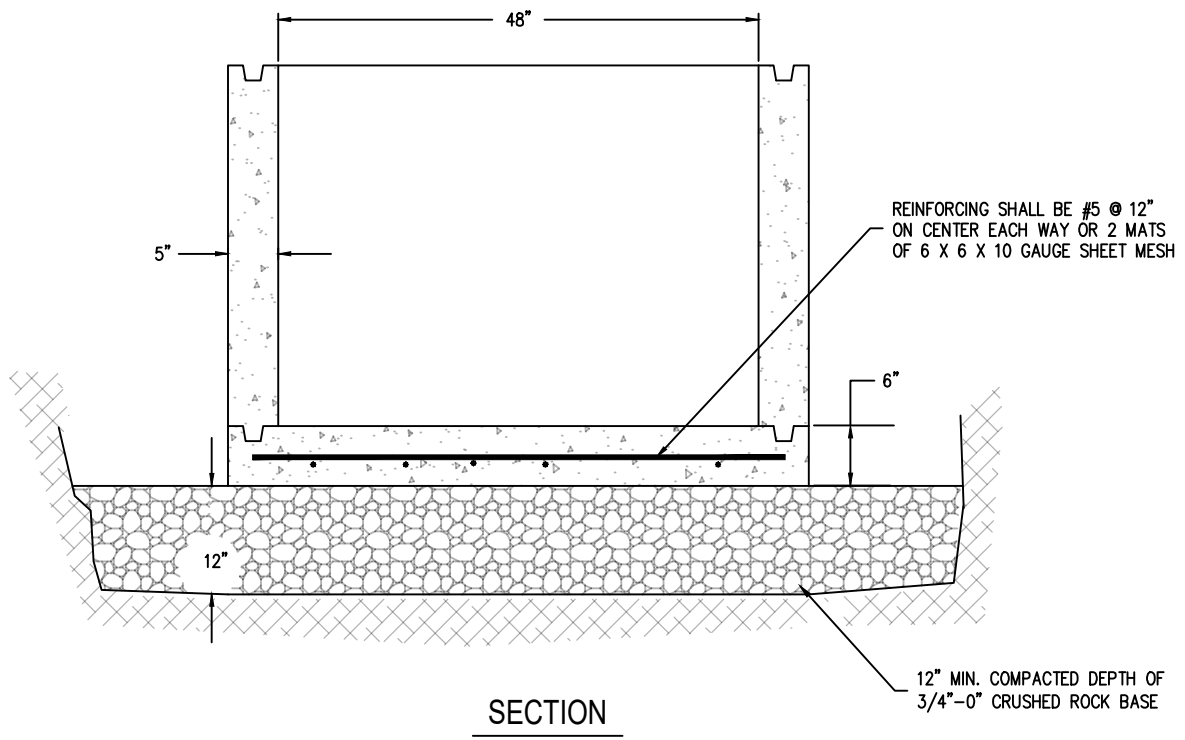

**NOTES:**

1. ALL MANHOLE BASE SECTIONS SHALL BE PRE-CAST CONCRETE, EXCEPT THOSE LOCATED OVER EXISTING MAIN LINES.
2. PIPE CONNECTIONS MUST BE MADE TO PRE-CAST OR CORED HOLES WITH A KOR-N-SEAL BIT OR EQUIVALENT. SANDED COLLARS ARE NOT ACCEPTABLE.

| NO. | REVISIONS | DATE | BY |
|-----|-----------|------|----|
| 1   |           |      |    |
| 2   |           |      |    |
| 3   |           |      |    |
| 4   |           |      |    |

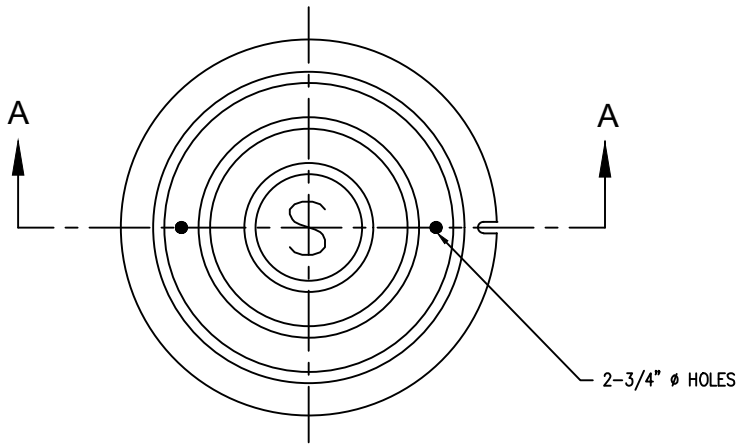

TOP VIEW

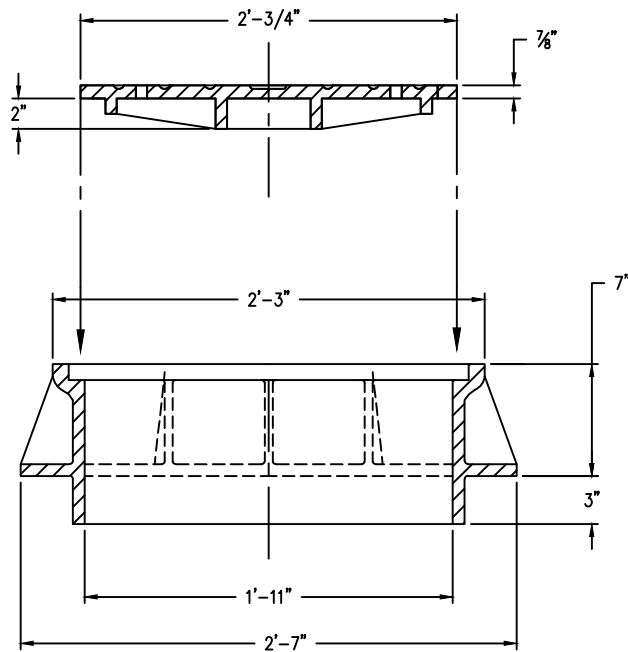

SECTION A-A

NOTES:

1. STANDARD FRAME AND COVER TO BE USED ON COLLECTOR, ARTERIAL, AND INDUSTRIAL STREETS OR AS NOTED ON CONSTRUCTION PLANS.
2. SANITARY COVER WILL HAVE TWO 3/4"  $\emptyset$  HOLES.

**OAK LODGE**  
 WATER SERVICES

FRAME & COVER (STANDARD)

DRAWING NO.

**308**

SANITARY SYSTEM STANDARD DRAWING

| NO. | REVISIONS | DATE | BY |
|-----|-----------|------|----|
| 1   |           |      |    |
| 2   |           |      |    |
| 3   |           |      |    |
| 4   |           |      |    |

DATE: 09/12/2017

SCALE: NTS

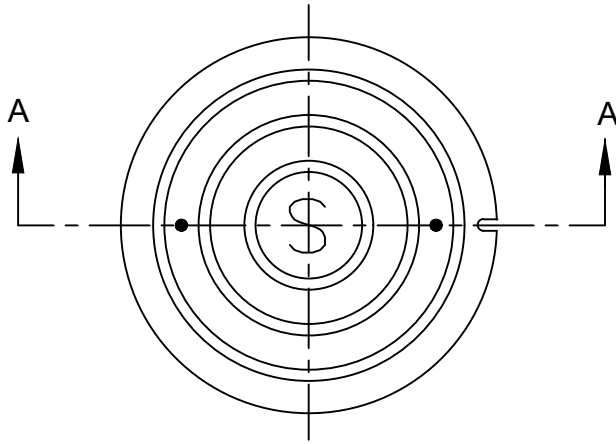

TOP VIEW

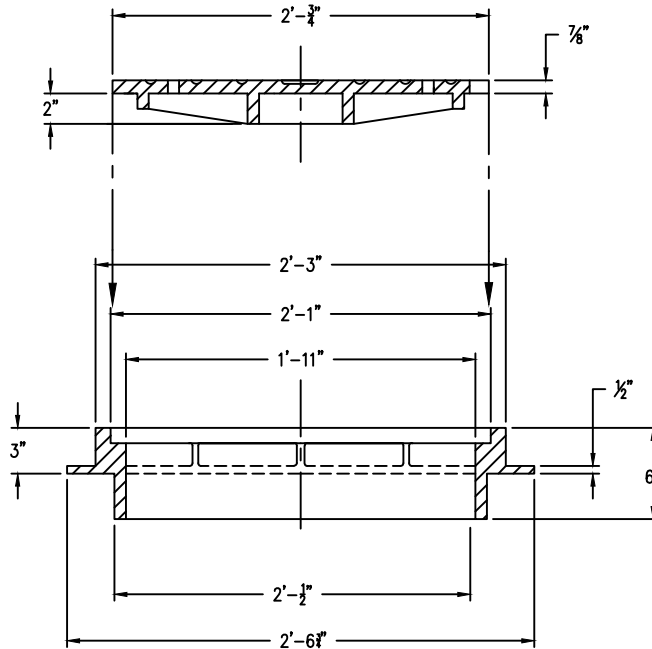

SECTION A-A

NOTES

1. COVER AND FRAME SHALL BE OF GRAY CAST IRON  
A.S.T.M. A-48 CLASS 30
2. SUBURBAN FRAME & COVER CAN BE USED IN  
EASEMENTS AND SUBDIVISION STREETS EXCEPT  
COLLECTOR, ARTERIAL, AND INDUSTRIAL STREETS, OR  
AS NOTED ON CONSTRUCTION PLANS.
3. SANITARY COVER WILL HAVE TWO 3/4" Ø HOLES.

**OAK LODGE**  
WATER SERVICES

SANITARY SYSTEM STANDARD DRAWING

FRAME & COVER (SUBURBAN)

| NO. | REVISIONS | DATE | BY |
|-----|-----------|------|----|
| 1   |           |      |    |
| 2   |           |      |    |
| 3   |           |      |    |
| 4   |           |      |    |

DRAWING NO.

309

DATE: 09/12/2017

SCALE: NTS

**TAMPERPROOF MANHOLE RING**

**3-BOLTDOWN COVER**

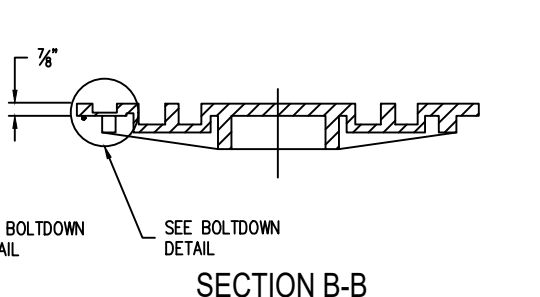
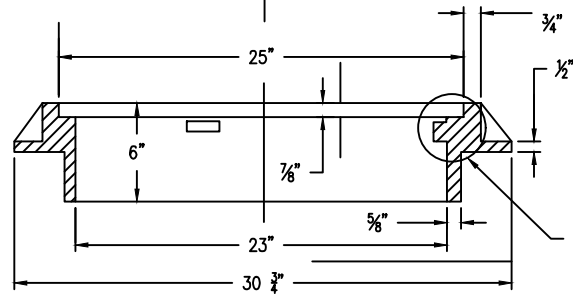
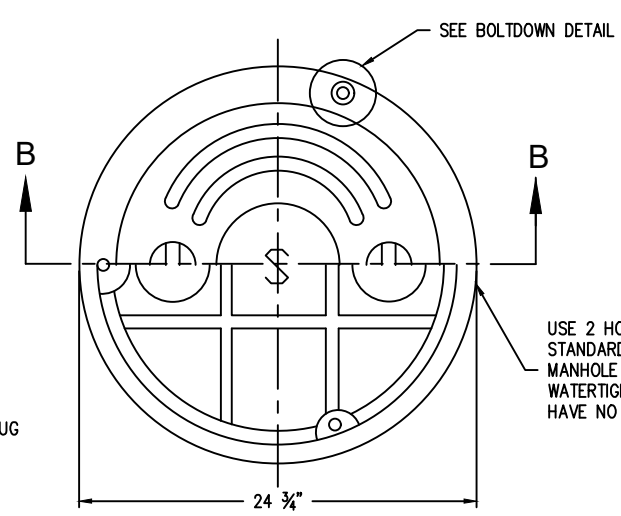
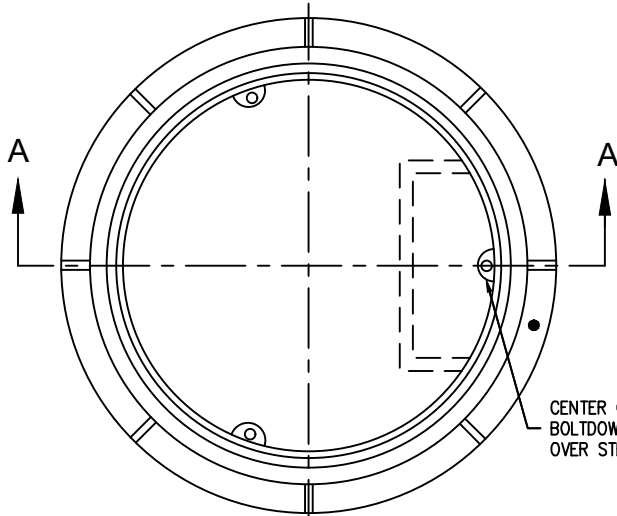

**SECTION A-A**

**SECTION B-B**

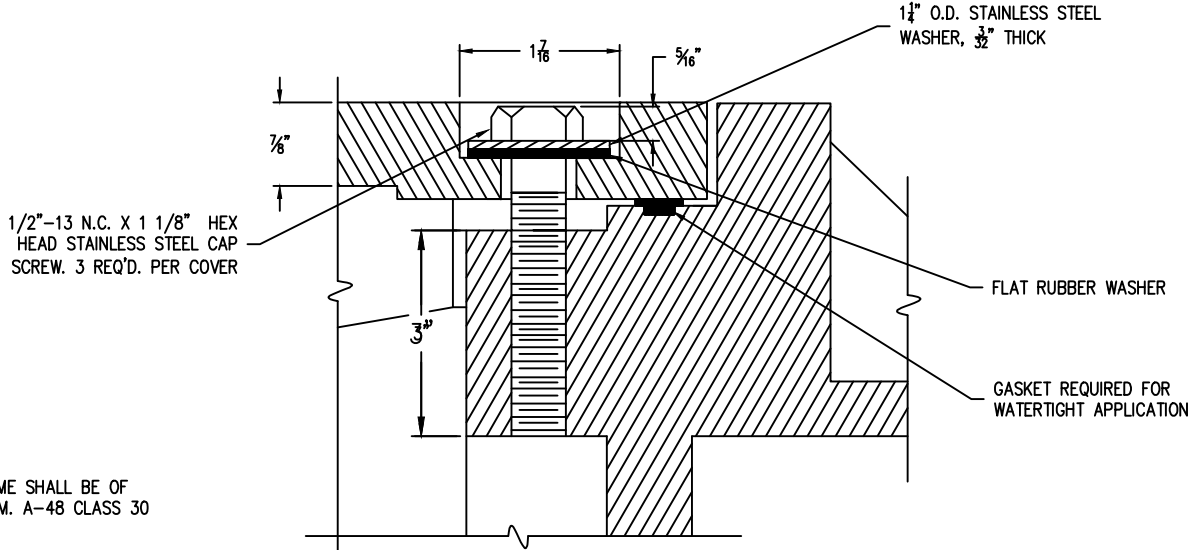

**BOLT-DOWN DETAIL**

NOTE: COVER AND FRAME SHALL BE OF GRAY CAST IRON A.S.T.M. A-48 CLASS 30

**OAK LODGE**  
 WATER SERVICES  
 SANITARY SYSTEM STANDARD DRAWING

**FRAME & COVER (SECURE / WATERTIGHT)**

| NO. | REVISIONS | DATE | BY |
|-----|-----------|------|----|
| 1   |           |      |    |
| 2   |           |      |    |
| 3   |           |      |    |
| 4   |           |      |    |

DRAWING NO.  
**310**

DATE: 09/12/2017  
 SCALE: NTS

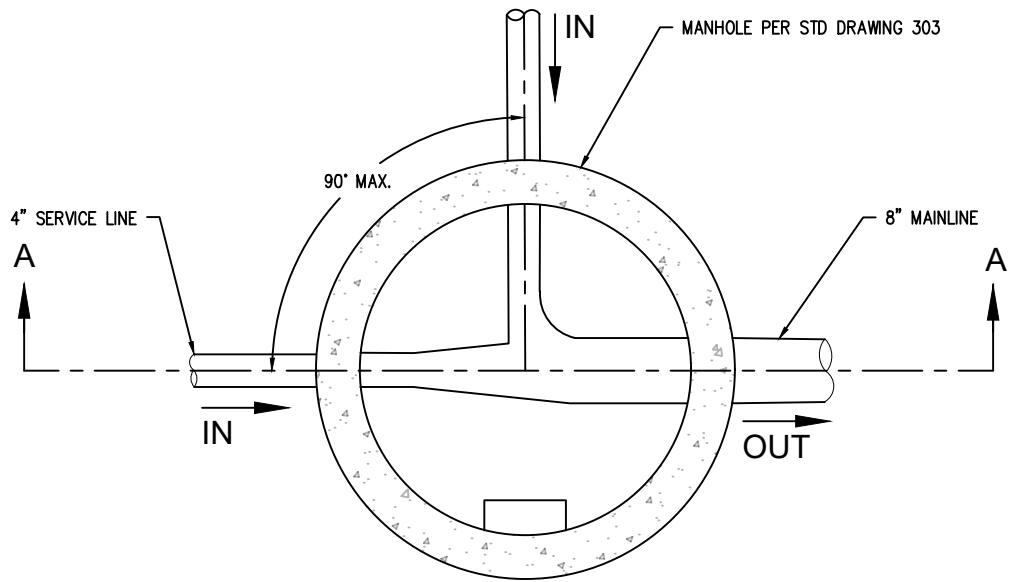

PLAN

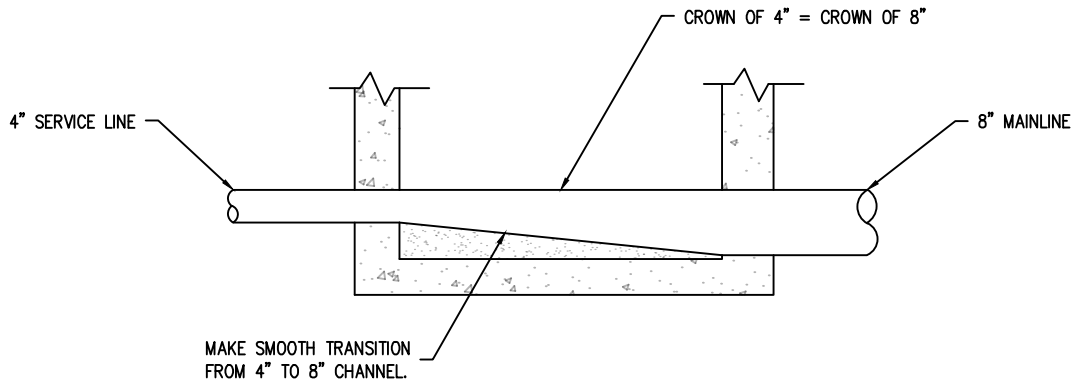

SECTION A-A

NOTES:

1. CHANNEL MANHOLE TO MATCH INLET & OUTLET PIPE DIAMETERS & PROVIDE SMOOTH TRANSITION.
2. MATCH CROWN OF INLET & OUTLET PIPES & CHANNELIZATION.

| NO. | REVISIONS | DATE | BY |
|-----|-----------|------|----|
| 1   |           |      |    |
| 2   |           |      |    |
| 3   |           |      |    |
| 4   |           |      |    |

1. OLWS MAY ALLOW INSIDE DROP SERVICE CONNECTIONS AT THE DISCRETION OF THE DISTRICT ENGINEER.
2. INSIDE DROPS MAY BE 4" OR 6" & SHALL BE SIZED TO MATCH THE INFLOW PIPE.
3. THE ENTRY POINT IN THE MANHOLE WALL MUST BE CORE DRILLED.
4. THE SERVICE LATERAL IS TO BE SEALED INTO THE CORED HOLE WITH A KOR-N-SEAL BOOT OR EQUIVALENT.
5. THE SERVICE LATERAL WILL COUPLE DIRECTLY TO A PVC SLIP TEE IN THE MANHOLE TO ALLOW THE DROP PIPE TO CONTACT THE MH WALL FOR ITS ENTIRE LENGTH.
6. THE DROP PIPE, 45° BEND, AND EXTENSION PIPE ARE TO HAVE GLUED JOINTS.
7. THE DROP PIPE EXTENSION MUST CONVEY SEWAGE ALL THE WAY TO THE MAIN CHANNEL.
8. THE DROP PIPE IS TO BE SECURED TO THE MANHOLE WALL BY:  
 STAINLESS STEEL STRAPS MEASURING A MINIMUM OF 1-1/2" WIDE BY 1/8" THICK;  
 STRAP SPACING WILL BE 3' ON CENTER, WITH A MINIMUM OF 2 STRAPS;  
 EACH STRAP WILL BE SECURED TO THE WALL BY A PAIR OF 5/16" STAINLESS STEEL WEDGE ANCHORS.
9. THE ANNULAR SPACE AT THE CORED HOLE IS TO BE GROUTED NEATLY AFTER ASSEMBLY.

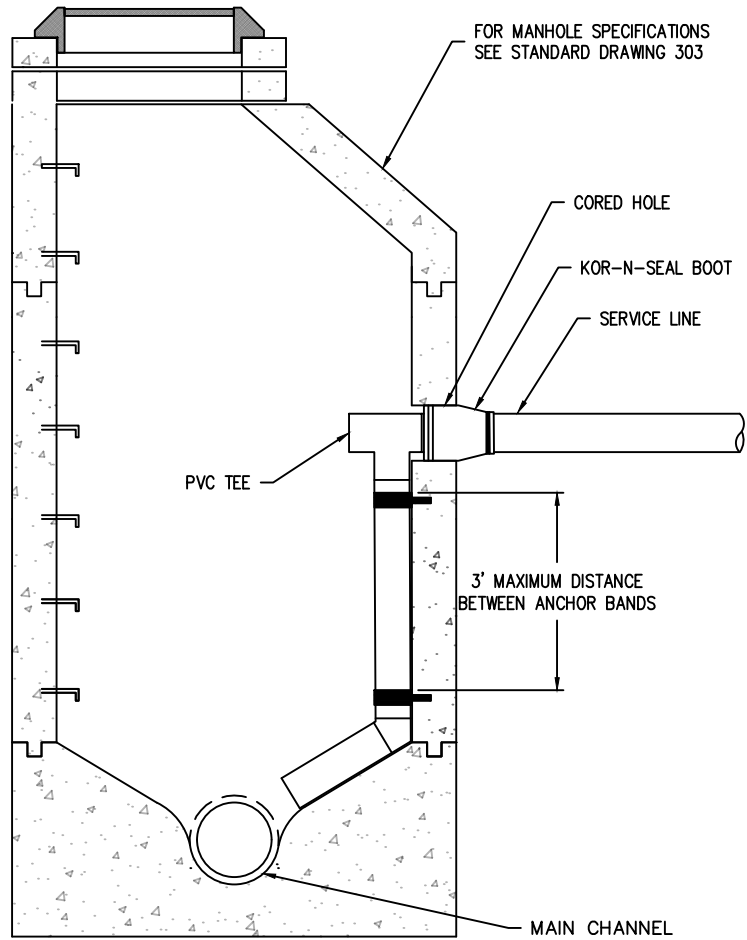

SECTION

| NO. | REVISIONS     | DATE     | BY  |
|-----|---------------|----------|-----|
| 1   | MISC CALLOUTS | 1/9/2019 | HSO |
| 2   |               |          |     |
| 3   |               |          |     |
| 4   |               |          |     |

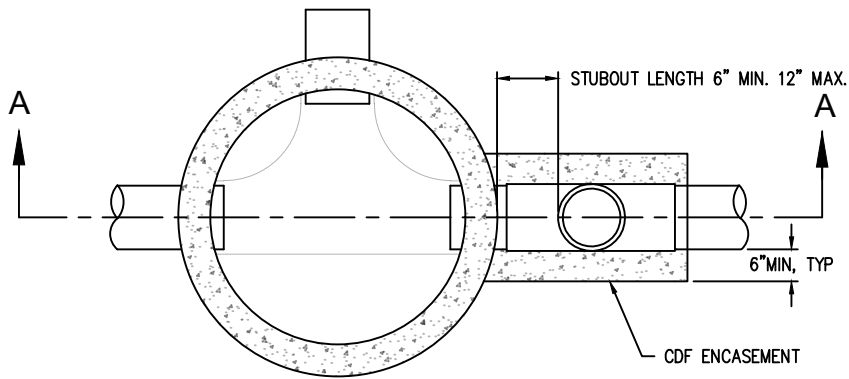

PLAN

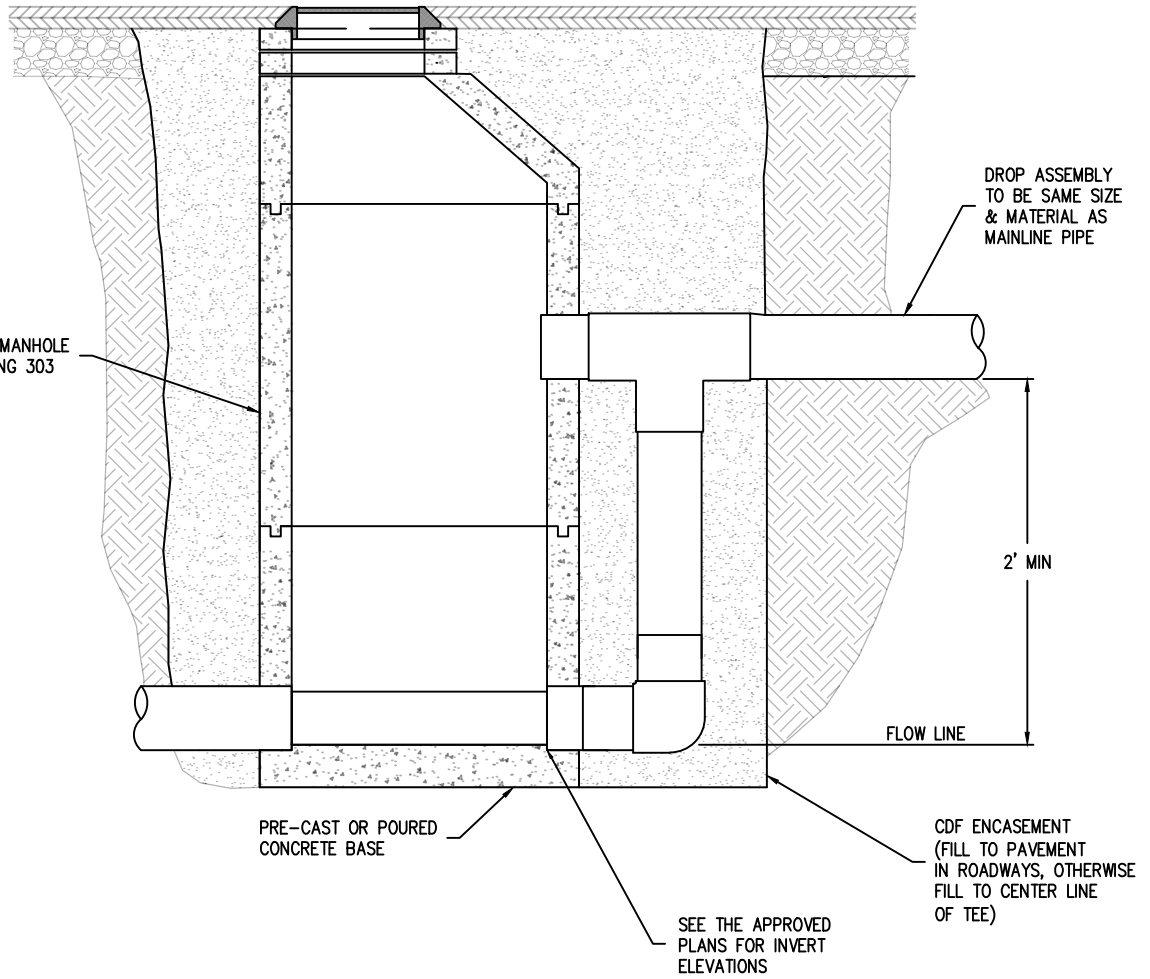

SECTION A-A

| NO. | REVISIONS | DATE | BY |
|-----|-----------|------|----|
| 1   |           |      |    |
| 2   |           |      |    |
| 3   |           |      |    |
| 4   |           |      |    |

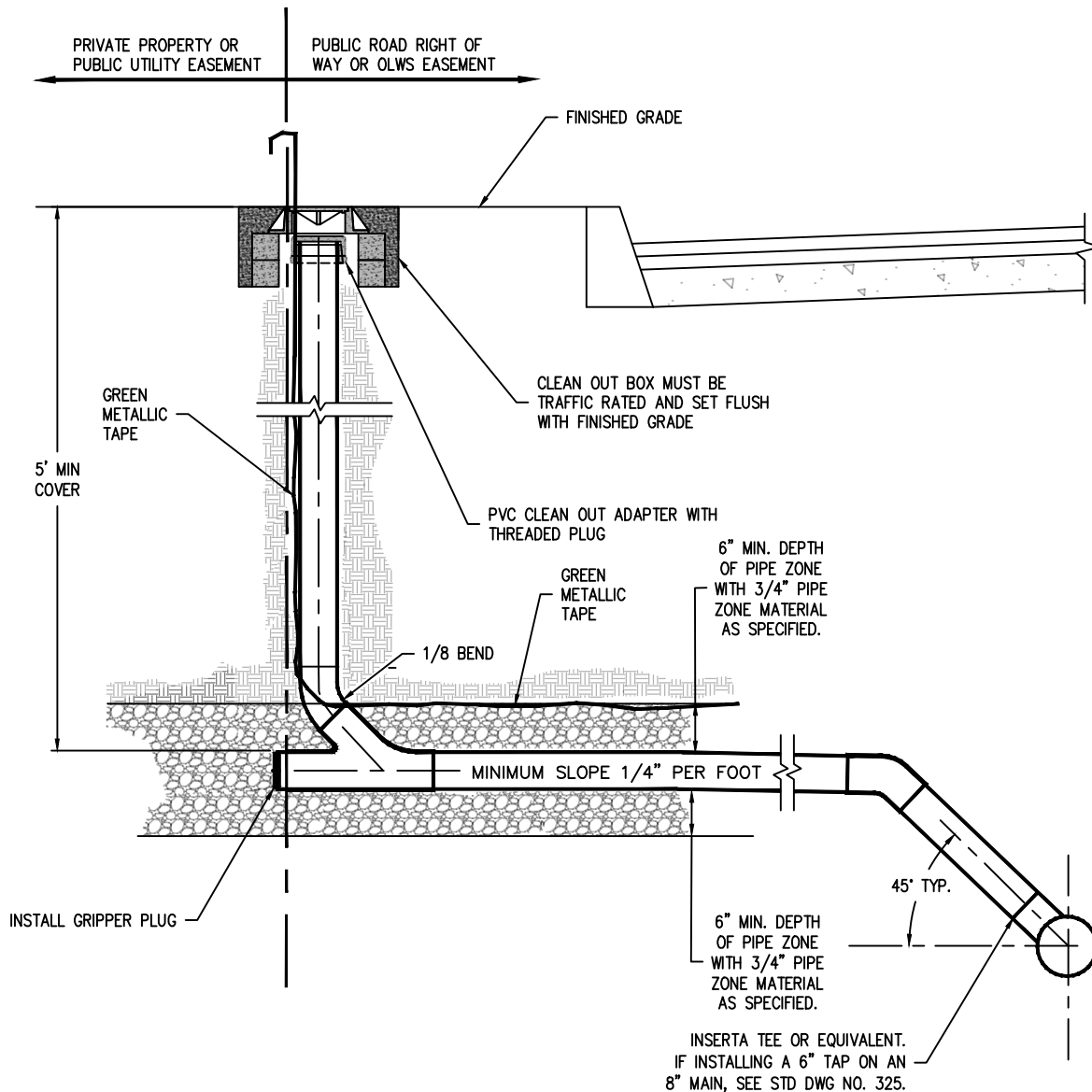

**NOTES:**

1. 4" LATERALS MUST HAVE 4" CLEAN OUT RISERS, AND 6" LATERALS MUST HAVE 6" CLEAN OUT RISERS.
2. THE CLEAN OUT RISER MUST BE LOCATED WITHIN 6" OF THE PROPERTY LINE AND JUST INSIDE THE ROAD RIGHT OF WAY OR THE OLWS EASEMENT. THE CLEAN OUT RISERS MAY NOT BE LOCATED ON PRIVATE PROPERTY OR IN A PUBLIC UTILITY EASEMENT.
3. THE LATERAL MUST BE INSTALLED WITH A MINIMUM GRADE OF 2% AND MUST RUN PERPENDICULAR FROM THE MAIN TO THE CLEAN OUT.
4. THE CLEAN OUT RISER MUST BE TOPPED WITH A PVC CLEAN OUT ADAPTER WITH A THREADED PLUG.
5. THE CLEAN OUT MUST BE PROTECTED BY A TRAFFIC RATED BOX. EITHER A CAST IRON UNIT OR A COMBINATION CONCRETE AND CAST IRON UNIT IS ACCEPTABLE.
6. OLWS MAY REQUIRE THE TV INSPECTION OF A LATERAL AFTER BACKFILL AND COMPACTION.

| NO. | REVISIONS                      | DATE     | BY  |
|-----|--------------------------------|----------|-----|
| 1   | MISC CALLOUTS, DIMS, AND NOTES | 1/9/2019 | HSO |
| 2   | NOTE CORRECTIONS               | 3/5/2024 | TAP |
| 3   |                                |          |     |
| 4   |                                |          |     |



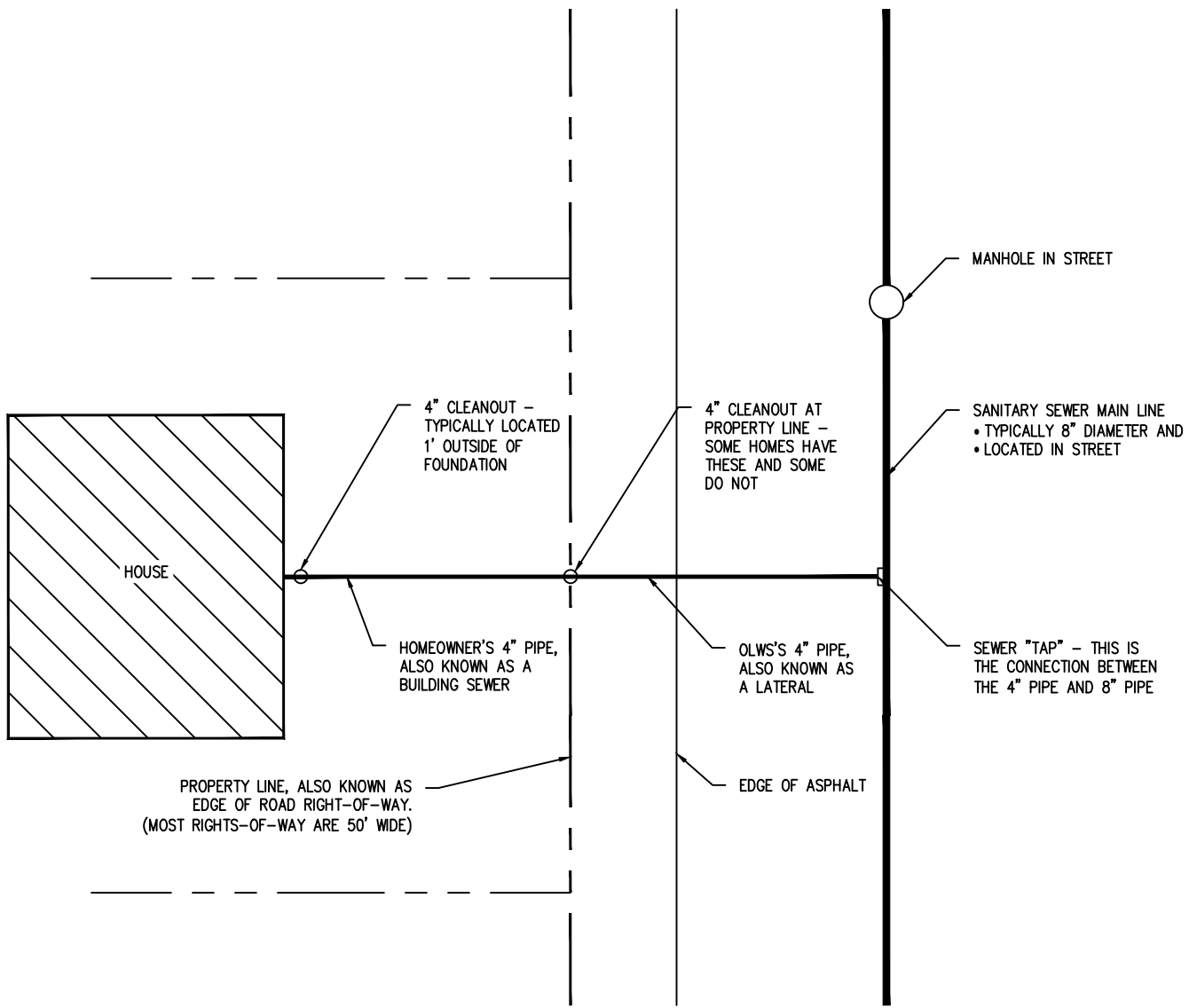

← PRIVATE PROPERTY | STREET →

| NO. | REVISIONS | DATE | BY |
|-----|-----------|------|----|
| 1   |           |      |    |
| 2   |           |      |    |
| 3   |           |      |    |
| 4   |           |      |    |

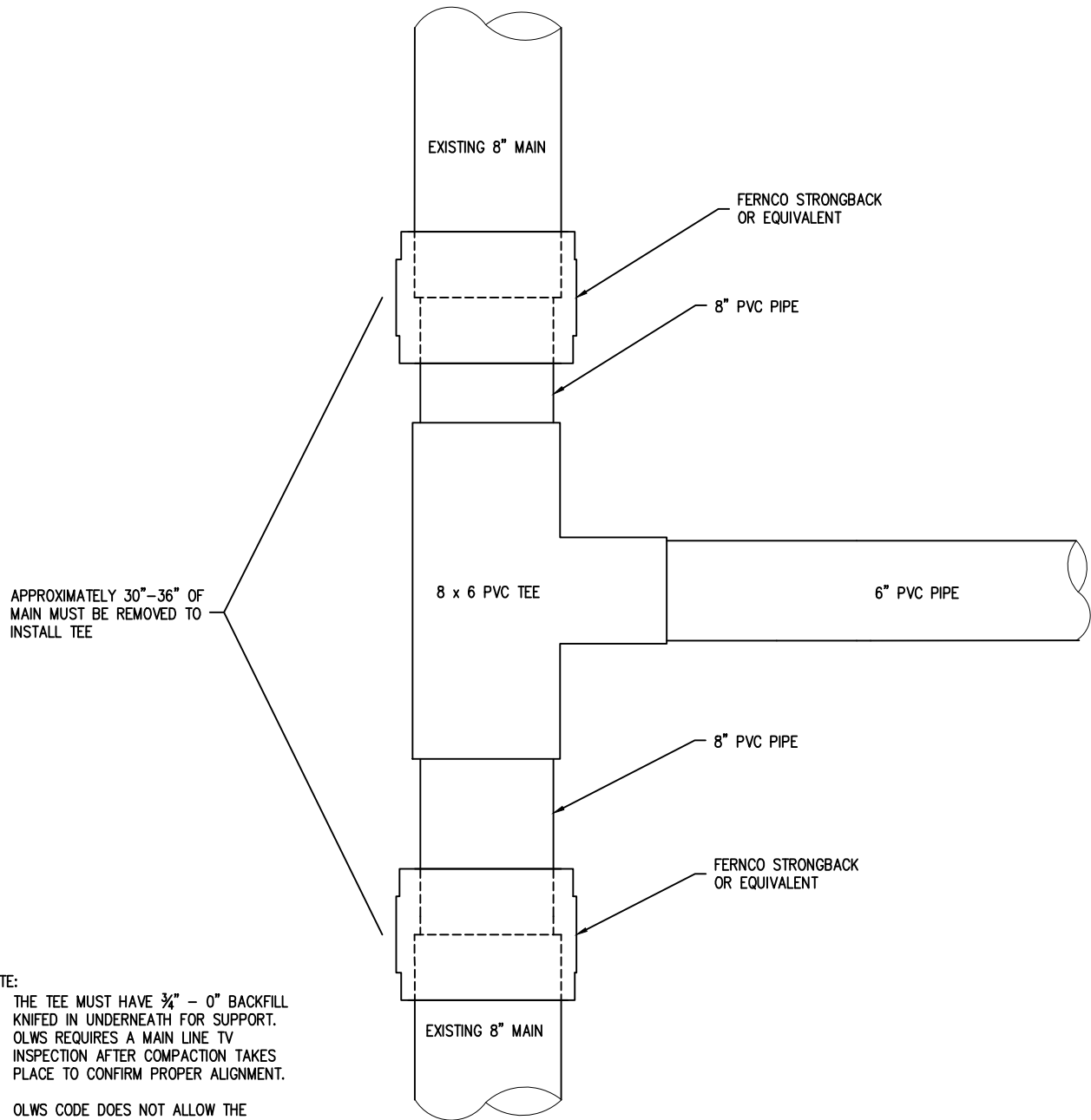

APPROXIMATELY 30"–36" OF MAIN MUST BE REMOVED TO INSTALL TEE

**NOTE:**

1. THE TEE MUST HAVE  $\frac{3}{4}$ " – 0" BACKFILL KNIFED IN UNDERNEATH FOR SUPPORT. OLWS REQUIRES A MAIN LINE TV INSPECTION AFTER COMPACTION TAKES PLACE TO CONFIRM PROPER ALIGNMENT.
2. OLWS CODE DOES NOT ALLOW THE INSTALLATION OF A 6" INSERTA TEE ON AN 8" MAIN LINE AS IT WEAKENS THE STRUCTURAL INTEGRITY OF THE MAIN LINE. INSTEAD, A SECTION OF MAINLINE MUST BE REMOVED AND AN 8"x 6" PVC TEE SPLICED IN TO PROVIDE THE NEW TAP. NOTE THAT THIS OPERATION WILL REQUIRE THE SUBMISSION OF A WRITTEN "PUMP AROUND PLAN" FOR OLWS REVIEW.

| NO. | REVISIONS                    | DATE     | BY  |
|-----|------------------------------|----------|-----|
| 1   | REMOVED COUPLER JOINT ON TEE | 1/9/2019 | HSD |
| 2   | NOTE CORRECTIONS             | 3/5/2024 | TAP |
| 3   |                              |          |     |
| 4   |                              |          |     |

# WATER SYSTEM STANDARD DRAWING INDEX

|     |                                     |
|-----|-------------------------------------|
| 400 | WATER SYSTEM STANDARD DRAWING INDEX |
| 401 | WATER SYSTEM CONSTRUCTION NOTES     |
| 402 | PIPE TRENCH                         |
| 407 | RESTRAINED JOINTS                   |
| 408 | TAPPING AND CUT-IN METHODS          |
| 410 | ISOLATION VALVE DETAIL              |
| 411 | FIRE HYDRANT ASSEMBLY               |
| 412 | FIRE HYDRANT LOCATIONS              |
| 413 | BLOWOFF ASSEMBLY                    |
| 420 | ONE INCH WATER SERVICE ASSEMBLY     |
| 421 | TWO INCH WATER SERVICE ASSEMBLY     |
| 422 | THREE INCH WATER SERVICES ASSEMBLY  |
| 430 | WATER METER LOCATION                |
| 435 | WATER SAMPLING STATION              |



**WATER SYSTEM STANDARD DRAWING**

## WATER SYSTEM STANDARD DRAWING INDEX

| NO. | REVISIONS                        | DATE       | BY  |
|-----|----------------------------------|------------|-----|
| 1   | MISC DRAWINGS REMOVED OR RENAMED | 01/29/2019 | HSO |
| 2   | INDEX CORRECTIONS, ADDED DRAWING | 7/30/2024  | TAP |
| 3   |                                  |            |     |
| 4   |                                  |            |     |

DRAWING NO.

# 400

DATE: 9/12/2017

SCALE: NTS

NOTES:

1. CONSTRUCTION OF IMPROVEMENTS SHALL BE IN ACCORDANCE WITH OAK LODGE WATER SERVICES (OLWS a.k.a. DISTRICT) DEVELOPER EXTENSION AGREEMENT (as applicable), DISTRICT STANDARD DETAILS AND THE OREGON STANDARD SPECIFICATIONS FOR CONSTRUCTION, MOST CURRENT EDITION, AS ISSUED BY THE OR. STATE DEPT. OF TRANSPORTATION.
2. A PRE-CONSTRUCTION CONFERENCE IS REQUIRED PRIOR TO CONSTRUCTION AND 48 HOURS ADVANCE NOTIFICATION OF THE LOCAL MUNICIPALITY, OLWS AND ALL AFFECTED UTILITY COMPANIES PRIOR TO THE ACTUAL START OF WORK.
3. THE CONTRACTOR SHALL BE RESPONSIBLE FOR COMPLYING WITH THE PROVISIONS OF THE ROAD OPENING PERMIT AS ISSUED BY CLACKAMAS COUNTY.
4. LOCATIONS OF EXISTING UTILITIES SHOWN ON THE PLANS ARE APPROXIMATE. IT SHALL BE THE CONTRACTOR'S RESPONSIBILITY TO VERIFY, LOCATE AND PROTECT ALL UTILITIES WITHIN THE PROJECT AREA. THE CONTRACTOR SHALL BE RESPONSIBLE FOR REPLACING OR REPAIRING ANY UTILITIES DAMAGED DURING CONSTRUCTION. SHOW THESE UTILITIES ON THE AS-BUILTS. IF A UTILITY IS DAMAGED, CONTRACTOR SHALL NOTIFY THE AFFECTED UTILITY COMPANY IMMEDIATELY.
5. ALL MAINS, SERVICES, VALVES, FITTINGS, AND OTHER APPURTENANCES MUST BE INSPECTED BY A DISTRICT REPRESENTATIVE BEFORE BURIAL.
6. WATER MAIN TRENCH SECTION AND ALL EXCAVATED AREAS SHALL BE BACKFILLED AND COMPACTED IN ACCORDANCE WITH THE STANDARD DETAILS, WITH SECTION 01140.40 OF THE STANDARD SPECIFICATIONS, AND WITH CLACKAMAS COUNTY ROAD OPENING PERMIT. COMPACTION TESTING SHALL BE REQUIRED DURING BACKFILLING OPERATIONS WITHIN ALL ROADWAYS AND AT THE DISCRETION OF THE DISTRICT. IF TRENCH BACKFILL DOES NOT MEET COMPACTION REQUIREMENTS, CONTRACTOR SHALL EXCAVATE, RECOMPACT AND RETEST MATERIAL AT CONTRACTOR'S EXPENSE.
7. RESTORATION OF DAMAGED ROAD SURFACING SHALL BE IN ACCORDANCE WITH CLACKAMAS COUNTY'S REQUIREMENTS. ALL OTHER AREAS SHALL BE RESTORED TO ORIGINAL CONDITION OR AS DIRECTED BY THE DISTRICT. THIS INCLUDES SHOULDERS, LANDSCAPING, WALLS, FENCES, DRIVEWAYS, AND OTHER IMPROVEMENTS.
8. THE WATER MAIN SHALL BE INSTALLED WITH A MINIMUM OF 36" OF COVER. INSTALLATION OF MAIN WITH GREATER THAN 48" OF COVER SHALL BE ACCEPTABLE ONLY UNDER THE DIRECTION OF THE DISTRICT.
9. ALL VALVES AND FITTINGS MUST BE MECHANICALLY RESTRAINED BY MEGALUG OR ROMAGRIP JOINT RESTRAINING GLANDS. ALL BELL AND SPIGOT JOINTS MUST BE RESTRAINED BY FIELD LOK GASKETS OR APPROVED EQUAL.
10. A SANITARY GAP MUST BE PROVIDED BETWEEN THE EXISTING AND NEW WATER SYSTEMS. CONNECTION TO THE EXISTING WATER SYSTEM SHALL BE PERFORMED BY THE CONTRACTOR ONLY AFTER COMPLETING OF AN ACCEPTABLE HYDROSTATIC PRESSURE TEST AND THE PIPELINE IS DISINFECTED AND RECEIPT OF APPROVAL OF WATER QUALITY TEST RESULTS FROM THE TESTING LAB.
11. CONTRACTOR SHALL PERFORM PRESSURE TEST AT 180psl OR 1.5 TIMES THE NORMAL WORKING PRESSURE, WHICHEVER IS HIGHER, INCLUDING ON HYDRANTS AND SERVICE LINES. MAINLINE SHALL BE TESTED IN SECTIONS OF NO MORE THAN 1,500 FEET. PRESSURE SHALL BE MAINTAINED FOR 1 HOUR MINIMUM. ANY LEAKAGE IS UNACCEPTABLE.
12. A PIPE PLUG SHALL BE USED ON EACH JOINT DURING INSTALLATION TO PROTECT AGAINST FLOODING OF THE PIPE.
13. NO OTHER UTILITIES SHALL BE INSTALLED WITHIN 36" HORIZONTALLY OF ANY ACTIVE WATER LINE UNLESS OTHERWISE PRE-APPROVED BY THE DISTRICT.
14. CONTRACTOR SHALL POTHOLE A SUFFICIENT DISTANCE AHEAD TO VERIFY DEPTH OF ALL EXISTING WATER MAINS AND CROSSING UTILITIES PRIOR TO CONSTRUCTION AND CONNECTIONS AND TO ANTICIPATE ANY NECESSARY CHANGES IN FITTINGS OR ALIGNMENT.
15. A PROPOSED CONSTRUCTION DRAWING MUST BE SUBMITTED TO THE DISTRICT BEFORE WATER SERVICE WILL BE PROVIDED.
16. DEFLECTION AT PIPE AND FITTING JOINTS WILL BE ALLOWED UP TO 3.0" (11" OVER 18') OR AS RECOMMENDED BY MANUFACTURER, WHICHEVER IS LESS.
17. CONTRACTOR SHALL ONLY DISPOSE OF WASTE MATERIAL AT SITES APPROVED BY CLACKAMAS COUNTY. STOCKPILE MATERIALS ONLY ON DISTRICT APPROVED SITES.
18. **HATCH NOTE:** ALL VAULT HATCHES 2'x2' OR LARGER SHALL BE HINGED, SPRING ASSIST OPENING, INCLUDE RECESSED PADLOCK HASP, DRAINABLE FRAME (C OR U CHANNEL WITH PIPE CONNECTION), H2O RATED MINIMUM, ALUMINUM OR GALVANIZED STEEL. IF HATCH WILL BE LOCATED IN A TRAVELED AREA (ROAD OR DRIVEWAY), SUBMIT MANUFACTURER'S STATEMENT THAT HATCH IS RATED FOR CONTINUOUS AND DELIBERATE H2O TRAFFIC SERVICE. HATCHES SHALL BE CAST INTO VAULT LID OR RISER.
19. ALL PIPE 3" AND LARGER SHALL BE DUCTILE IRON (DI) MINIMUM CLASS 52 (12" AND SMALLER), EXCEPT WHERE TRENCH BACKFILL AND LOADING DICTATE A STRONGER CLASS PIPE OR IN AREAS WHERE PRESSURE EXCEEDS 150 PSI. ALL HYDRANT RUNS AND PIPING INSTALLED WITH MEGA-LUG TYPE JOINT RESTRAINTS SHALL BE DUCTILE IRON PIPE CLASS 52, NO EXCEPTIONS. PIPING INSTALLED WITHIN VAULTS OR OTHER EXPOSED AREAS SHALL BE DUCTILE IRON CLASS 53.
20. CASINGS SHALL BE NEW STEEL, HDPE OR PVC; MATERIAL AND WALL THICKNESS AT THE DISCRETION OF THE DISTRICT. PIPE THROUGH CASINGS SHALL BE SUPPORTED WITH RUNNERS SPACED NO FARTHER THAN 8 FEET APART. RUNNERS SHALL BE MANUFACTURED PRODUCTS (PSI, CALPICO, OR APPROVED EQUAL), NO BLOCKS AND STRAPS. CASING ENDS SHALL BE CAPPED WITH MANUFACTURED CASING END SEALS.
21. WATER MAINS AND SERVICES MUST BE INSTALLED A MINIMUM CLEAR DISTANCE OF 5 FEET HORIZONTALLY FROM SANITARY SEWERS.
22. CONTRACTORS WORKING WITHIN THE RIGHT OF WAY OR ON EXISTING DISTRICT INFRASTRUCTURE SHALL BE LICENSED, BONDED AND HAVE EXPERIENCE INSTALLING PUBLIC DOMESTIC WATER SYSTEMS AND BE PREPARED TO PRESENT EXAMPLES OF 5 SUCH PROJECTS UPON REQUEST BY THE DISTRICT.

WATER SYSTEM CONSTRUCTION NOTES

| NO. | REVISIONS  | DATE       | BY  |
|-----|------------|------------|-----|
| 1   | MISC NOTES | 02/18/2020 | HSO |
| 2   |            |            |     |
| 3   |            |            |     |
| 4   |            |            |     |

DRAWING NO.

401

DATE: 9/12/2017

SCALE: NTS

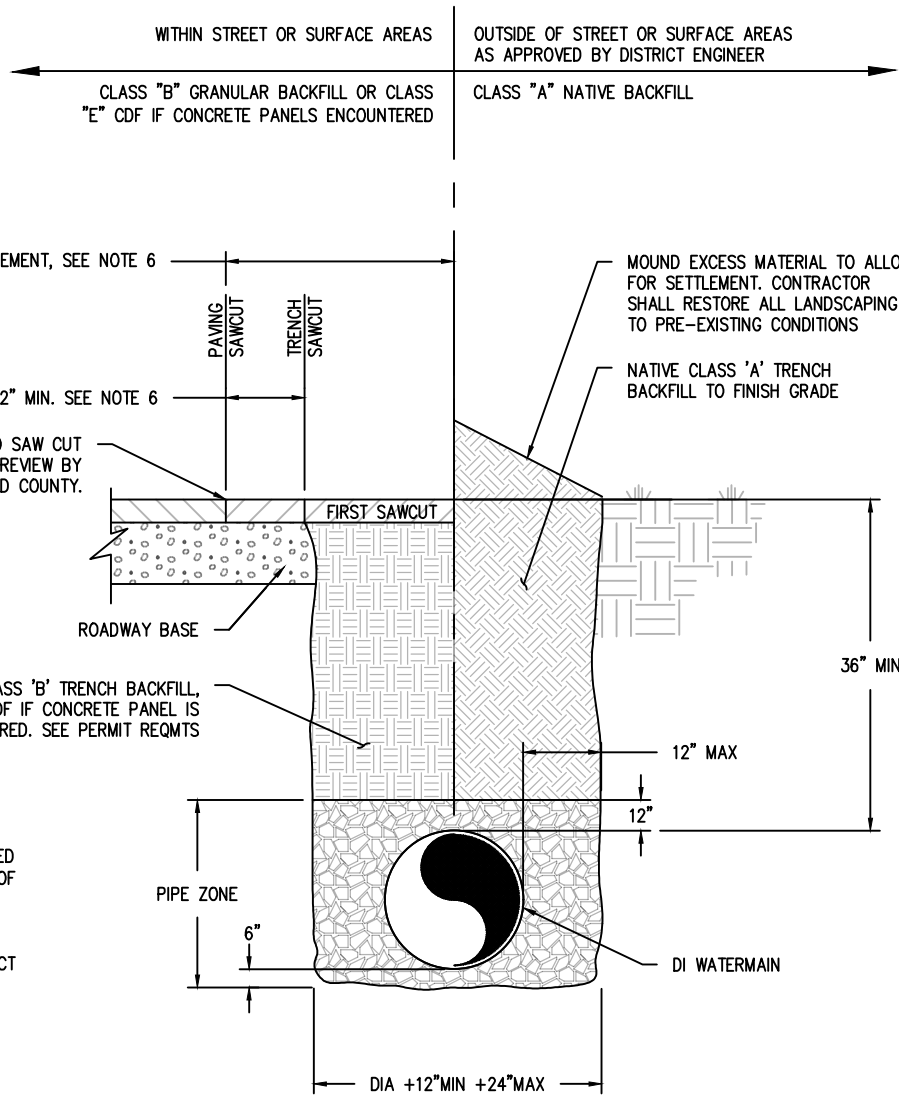

**NOTES:**

1. PIPE ZONE MATERIAL SHALL BE 3/4"-0" CRUSHED ROCK GRANULAR BACKFILL COMPACTED TO 95% OF AASHTO T-99.
2. CLASS "A" NATIVE BACKFILL MAY ONLY BE USED OUTSIDE OF PAVED AREAS AND REQUIRES DISTRICT APPROVAL. BACKFILL SHALL BE COMPACTED TO 90% OF AASHTO T-99 IN LIFTS NOT EXCEEDING 18" (LOOSE MEASURE).
3. CLASS "B" 3/4"-0" CRUSHED ROCK GRANULAR BACKFILL SHALL BE USED WITHIN PAVED AREAS. BACKFILL SHALL BE COMPACTED TO 95% OF AASHTO T-99.
4. BACKFILL SHALL BE PLACED AND COMPACTED IN A MAXIMUM OF 24-INCH LIFTS. COMPACTION TESTING REQUIRED PER COUNTY SPECIFICATIONS.
5. COMPLETE SURFACE AND PAVEMENT RESTORATION IN ACCORDANCE WITH THE PROVISIONS OF THE ROAD OPENING PERMIT FROM CLACKAMAS COUNTY.
6. SAWCUT WIDTH AND AC PAVEMENT REPLACEMENT SHALL BE PER APPLICABLE JURISDICTIONAL REQUIREMENTS. SAWCUT CLEAN EDGE FOR AC PAVEMENT REPLACEMENT. SAND SEAL JOINT.
7. PROVIDE CLASS "E" CDF BACKFILL FOR ALL TRENCH CROSSINGS LOCATED IN VEHICLE TRAVEL LANES OF ARTERIAL & COLLECTOR STREETS, OR WHERE CONCRETE PANELS ARE ENCOUNTERED. IF THESE SPECIFICATIONS CONFLICT WITH THE SPECIFICATIONS OF ANOTHER APPLICABLE JURISDICTION, THE MORE STRINGENT SPECIFICATION SHALL GOVERN.

TYPICAL PIPE TRENCH DETAIL

DRAWING NO.

402

| NO. | REVISIONS | DATE | BY |
|-----|-----------|------|----|
| 1   |           |      |    |
| 2   |           |      |    |
| 3   |           |      |    |
| 4   |           |      |    |

DATE: 02/18/2020

SCALE: NTS

RESTRAINED JOINT PIPE IS APPROPRIATE TO USE IN MANY SITUATIONS. HOWEVER, OLWS WILL BE THE SOLE DETERMINER IF THE APPLICATION IS APPROPRIATE ON A GIVEN JOB. TYPICAL APPLICATIONS INCLUDE:

1. DEAD END MAINS THAT MAY BE EXTENDED.
2. SOILS NOT SUPPORTIVE OF THRUST BLOCKING.
3. INSUFFICIENT BEARING SOIL BEHIND FITTINGS.
4. VERTICAL BENDS (not covered here. must be designed by engineer for each job)

THE FOLLOWING PRODUCTS ARE PRE-APPROVED FOR USE IN RESTRAINED JOINT APPLICATIONS. ALL RESTRAINED JOINT PIPE SHALL BE DUCTILE IRON, UNLESS OTHERWISE APPROVED IN WRITING BY THE DISTRICT.

1. GRIFFIN: SNAP-LOK or BOLT-LOK
2. US PIPE: TR-FLEX or FIELD-LOK GASKET
3. PACIFIC STATES: THRUST-LOCK
4. EBAA IRON: MEGALUG
5. ROMAC: ROMAGRIP

THE FOLLOWING TABLE HAS BEEN DEVELOPED USING THE DUCTILE IRON PIPE RESEARCH ASSOCIATION RESTRAINED JOINT CALCULATOR. THE FOLLOWING CONDITIONS MUST BE MET FOR THESE RESULTS TO BE VALID. IF ANY OF THESE CONDITIONS CANNOT BE MET, PROJECT SPECIFIC CALCULATIONS MUST BE PROVIDED:

- A) THIS TABLE ONLY FOR BARE DUCTILE IRON PIPE. ANY OTHER TYPES OF PIPE WILL REQUIRE RE-EVALUATION.
- B) PIPE LAYING CONDITION TYPE 4 or 5. SELECT GRANULAR BEDDING MATERIAL BELOW PIPE. PIPE ZONE MATERIAL EXTENDING TO TOP OF PIPE MECHANICALLY COMPACTED. PIPE RESTING DIRECTLY ON NATIVE TRENCH BOTTOM IS NOT ACCEPTABLE.
- C) BEDDING SAND IS WELL GRADED WITH FINES. IF GRAVELLY SAND IS USED, LENGTHS MUST BE MULTIPLIED BY 1.3
- D) DEPTH OF COVER IS 3 FEET MINIMUM.
- E) 300psi TEST PRESSURE MAXIMUM. FOR HIGHER TEST PRESSURE, TABLE LENGTHS MUST BE MULTIPLIED BY THE PROPORTIONAL DIFFERENCE. EXAMPLE: FOR 350psi,  $350/300=1.17$  THEREFORE, LENGTHS MUST BE MULTIPLIED BY 1.17

THE LENGTH "L" GIVEN BELOW INDICATES THE DISTANCE THAT PIPE MUST BE RESTRAINED PAST THE FITTING JOINT. ALL JOINTS WITHIN THIS DISTANCE MUST BE RESTRAINED, INCLUDING THE FITTING.

| PIPE DIAMETER | RESTRAINED LENGTH, "L" |           |          |          |                         |          |            |
|---------------|------------------------|-----------|----------|----------|-------------------------|----------|------------|
|               | 11¼' BEND              | 22½' BEND | 45' BEND | 90' BEND | TEE w/SAME SIZE BRANCH* | DEAD END | REDUCER ** |
| 4"            | 3'                     | 5'        | 11'      | 25'      | 26'                     | 50'      | 30'        |
| 6"            | 4'                     | 7'        | 14'      | 36'      | 48'                     | 72'      | 37'        |
| 8"            | 5'                     | 10'       | 19'      | 46'      | 70'                     | 94'      | 67'        |
| 10"           | 6'                     | 11'       | 24'      | 56'      | 90'                     | 114'     | 70'        |
| 12"           | 7'                     | 13'       | 28'      | 66'      | 110'                    | 134'     | 71'        |
| 16"           | 10'                    | 17'       | 35'      | 85'      | 151'                    | 175'     | 104'       |
| 18"           | 11'                    | 19'       | 40'      | 95'      | 170'                    | 196'     | 106'       |

\* assumes all three legs restrained, and a minimum 5' stick of pipe in each run leg.  
 \*\* assumes reducer down 2 sizes. (example 12"x8"). Larger reductions shall be treated as a tee.

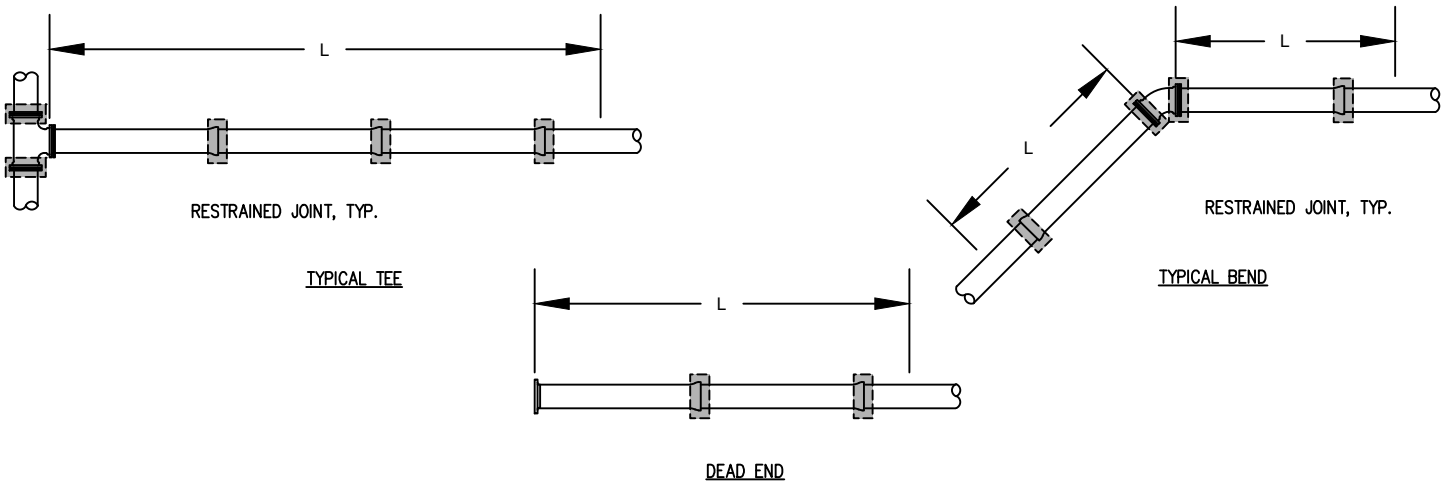

| NO. | REVISIONS     | DATE      | BY  |
|-----|---------------|-----------|-----|
| 1   | UPDATED NOTES | 3/11/2024 | TAP |
| 2   |               |           |     |
| 3   |               |           |     |
| 4   |               |           |     |

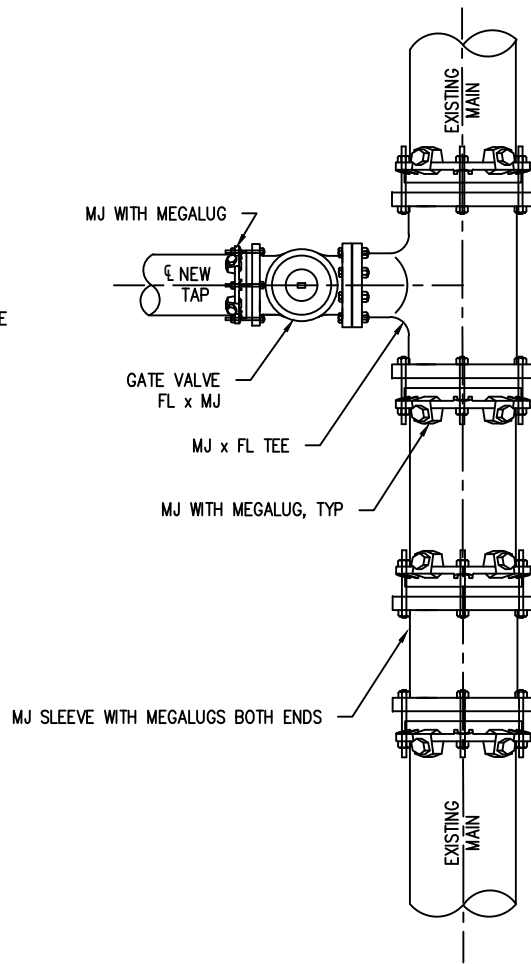
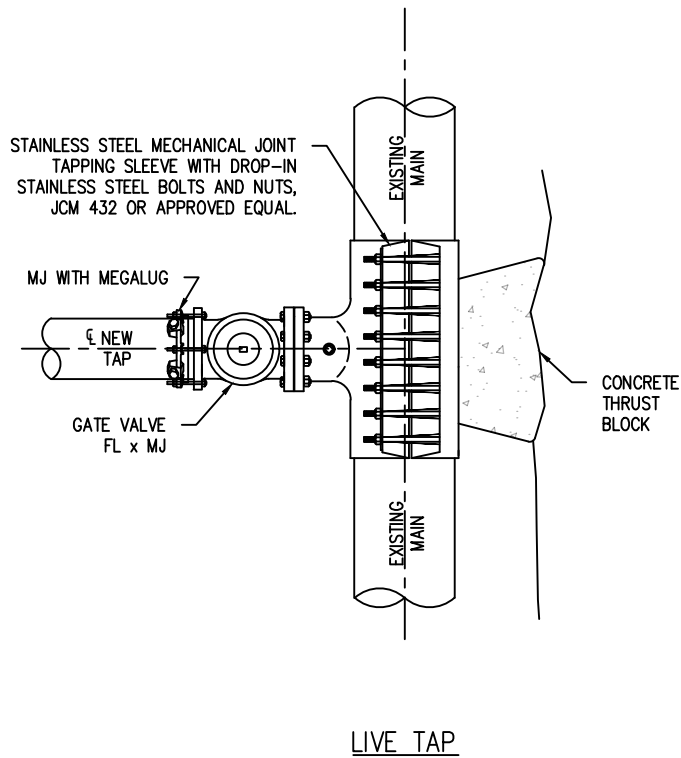

**NOTES:**

1. TAPPING SLEEVE SHALL BE STAINLESS STEEL MECHANICAL SLEEVE.
2. CONNECTIONS TO EXISTING MAIN SHALL BE PERFORMED UNDER THE DIRECT SUPERVISION OF OLWS AND WILL NOT BE ALLOWED ON FRIDAYS, HOLIDAYS OR WEEKENDS. VALVES SHALL BE OPERATED BY OLWS ONLY.
3. 11 MIL PLASTIC OR CONSTRUCTION FABRIC SHALL BE WRAPPED AROUND PIPE AND FITTINGS BEFORE THRUST BLOCK IS POURED.
4. SUPPORT VALVE AND SLEEVE CONTINUOUSLY THROUGH INSTALLATION.
5. TEST TAPPING SLEEVE PRIOR TO CUTTING EXISTING MAIN.

| NO. | REVISIONS                                | DATE     | BY  |
|-----|--|----------|-----|
| 1   | BACKFILL REMOVED, SLEEVE MATERIAL TO SST | 1/2/2020 | HSD |
| 2   |  |          |     |
| 3   |  |          |     |
| 4   |  |          |     |

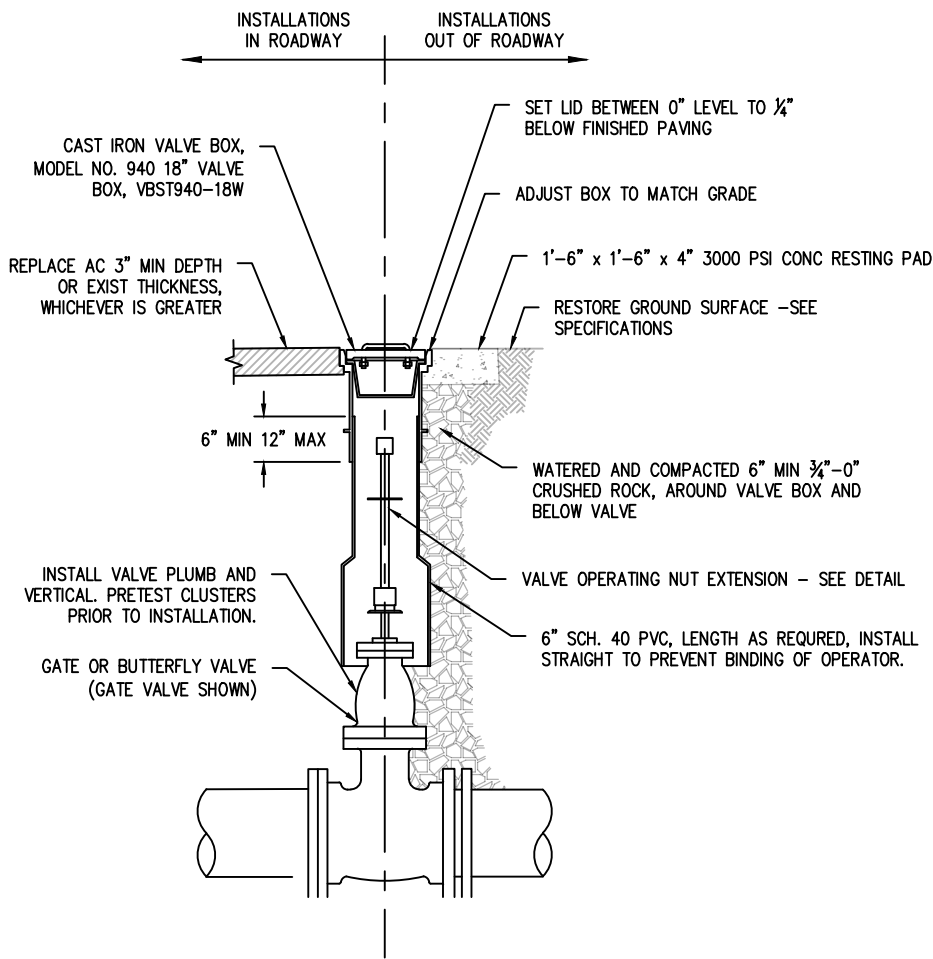

ISOLATION VALVE DETAIL

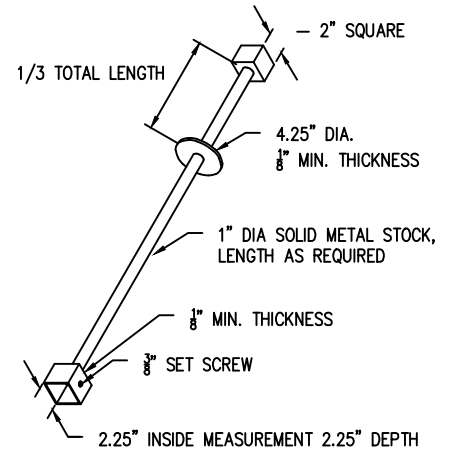

OPERATING NUT EXTENSION

**ISOLATION VALVE NOTES:**

1. VALVES SHALL BE INSTALLED AT NO MORE THAN 500 FT SPACING REGARDLESS OF MAIN SIZE.
2. ISOLATION VALVES 2" AND LARGER ARE TO BE NRS RESILIENT SEATED GATE VALVES MEETING AWWA C509 OR C515. VALVES 14" AND LARGER SHALL BE BUTTERFLY VALVES MEETING AWWA C504.
3. BACKFILL AROUND VALVE BOXES SHALL BE COMPACTED USING A JUMPING JACK.
4. STAR PIPE PRODUCTS MODEL NUMBERS SHOWN. OWNER APPROVED EQUALS WILL BE ALLOWED.
5. ALL VALVES SHALL BE SUPPLIED WITH VALVE BOX AND LID. LID SHALL HAVE RECESSED HANDLE.
6. ALL VALVES THAT WILL BE PART OF A CUT-IN CONNECTION OR HOT TAP ON AN EXISTING MAIN SHALL BE PRE-PRESSURE TESTED ON BOTH SIDES OF THE SEAT PRIOR TO INSTALLATION.

**OPERATING NUT EXTENSION NOTES:**

1. EXTENSIONS ARE REQUIRED WHEN THE VALVE NUT IS 5 FEET OR DEEPER BELOW FINISHED GRADE. EXTENSIONS ARE TO BE A MINIMUM OF ONE (1) FOOT LONG, ONLY ONE EXTENSION PER VALVE. ALL EXTENSIONS ARE TO BE SIZED AS NOTED AND MADE OF STEEL TO ASTM A36 A40 A120.
2. FOR EXTENSIONS LONGER THAN 4 FEET AND/OR VALVES LARGER THAN 12" DIAMETER, BAR SHALL BE 1 1/4" DIAMETER.

| NO. | REVISIONS                             | DATE       | BY  |
|-----|---------------------------------------|------------|-----|
| 1   | SPACING AND DEPTH REQ'D               | 02/18/2020 | HSO |
| 2   | SPACING AND DEPTH REQ'D               | 12/14/2020 | HSO |
| 3   | REVISED MANUFACTURER, EXTENSION REQ'D | 7/25/2024  | TAP |
| 4   |                                       |            |     |



# HYDRANT RELOCATION

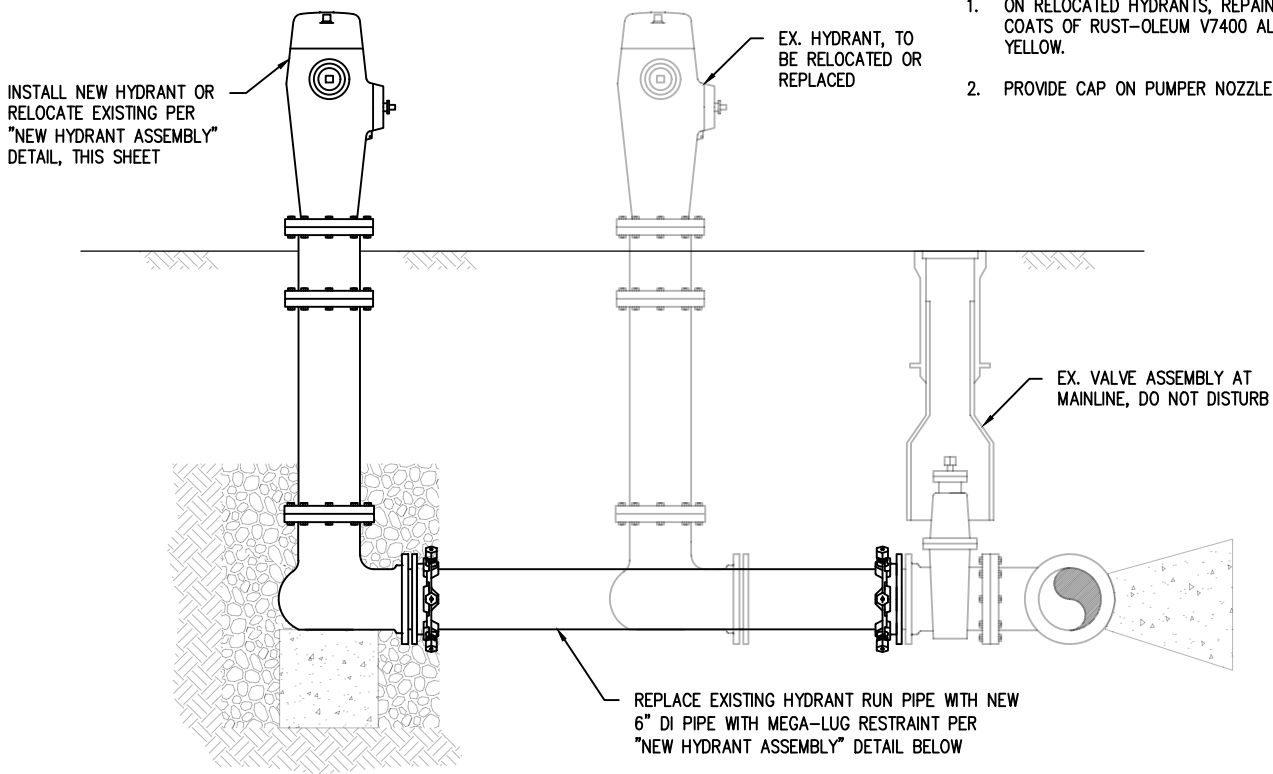

- RELOCATED HYDRANT NOTES:**
- ON RELOCATED HYDRANTS, REPAINT HYDRANTS WITH TWO COATS OF RUST-OLEUM V7400 ALKYD ENAMEL, FIRE HYDRANT YELLOW.
  - PROVIDE CAP ON PUMPER NOZZLE PER OLWS STANDARDS.

# NEW HYDRANT ASSEMBLY

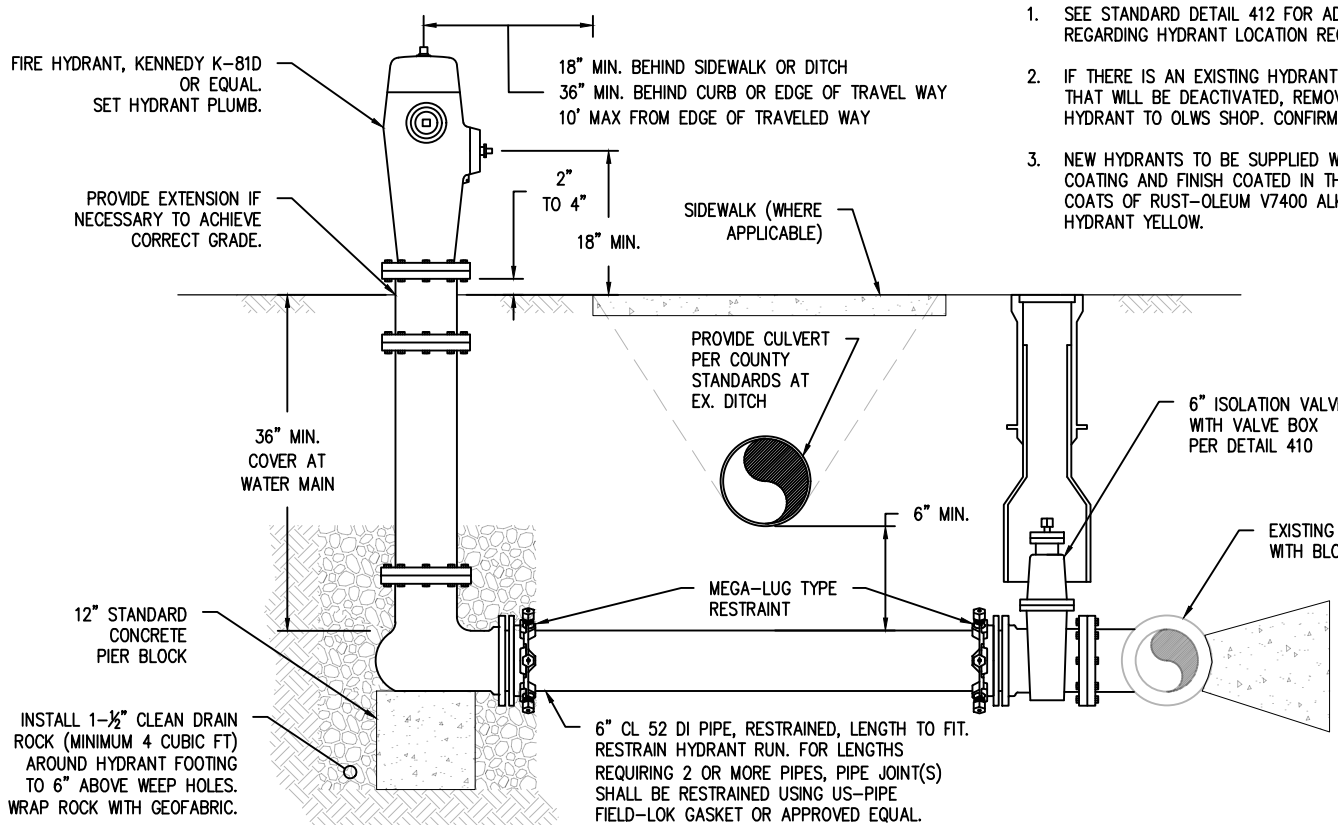

- NEW HYDRANT NOTES:**
- SEE STANDARD DETAIL 412 FOR ADDITIONAL DETAILS REGARDING HYDRANT LOCATION REQUIREMENTS.
  - IF THERE IS AN EXISTING HYDRANT IN THE VICINITY THAT WILL BE DEACTIVATED, REMOVE AND DELIVER HYDRANT TO OLWS SHOP. CONFIRM WITH OLWS.
  - NEW HYDRANTS TO BE SUPPLIED WITH FACTORY COATING AND FINISH COATED IN THE FIELD WITH TWO COATS OF RUST-OLEUM V7400 ALKYD ENAMEL, FIRE HYDRANT YELLOW.

**OAK LODGE**  
**WATER SERVICES**  
**WATER SYSTEM STANDARD DRAWING**

**FIRE HYDRANT ASSEMBLY**

| NO. | REVISIONS                          | DATE      | BY  |
|-----|------------------------------------|-----------|-----|
| 1   | MINOR DRAIN ROCK AND BLOCK CHANGES | 1/2/2020  | HSD |
| 2   | CHANGE TO FH MANUFACTURER          | 7/24/2024 | TAP |
| 3   |                                    |           |     |
| 4   |                                    |           |     |

DRAWING NO.  
**411**  
 DATE: 9/12/2017  
 SCALE: NTS

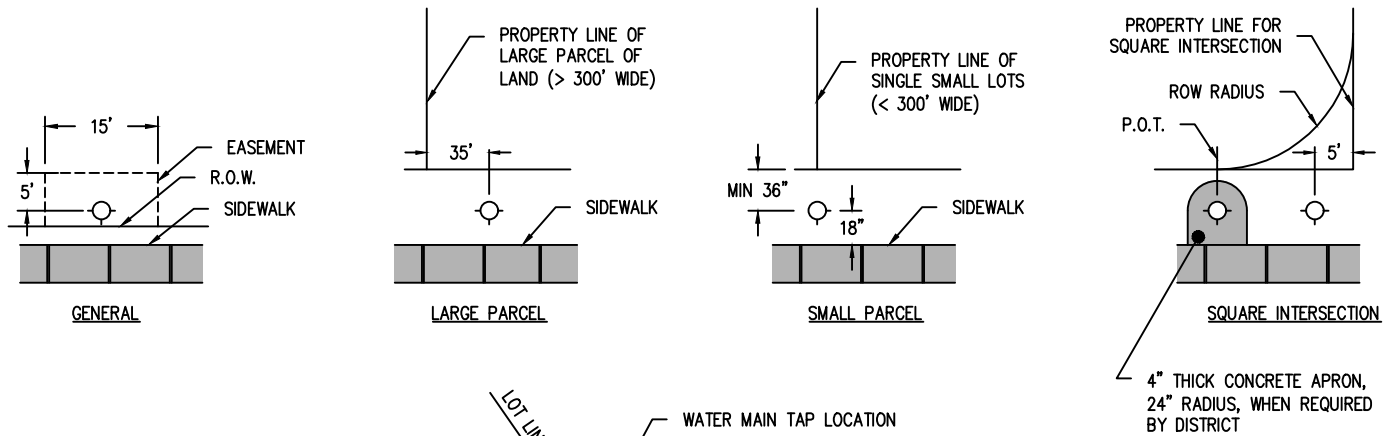

**HYDRANT LOCATIONS NOTES:**

1. COORDINATE HYDRANT LOCATION WITH DISTRICT.
2. HYDRANTS SHALL BE INSTALLED AT THE END OF ALL 8" DIAMETER AND LARGER DEAD END MAINS.
3. IF HYDRANT CANNOT BE LOCATED WITHIN ROW WITH 3' CLEAR, AN EASEMENT MUST BE PROVIDED.

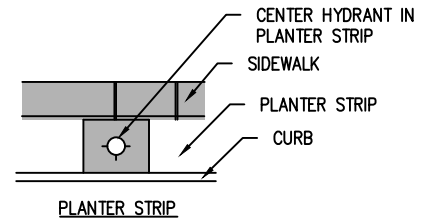
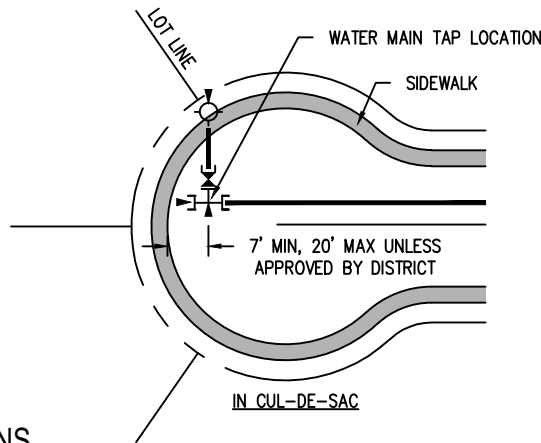

**TYPICAL HYDRANT LOCATIONS**

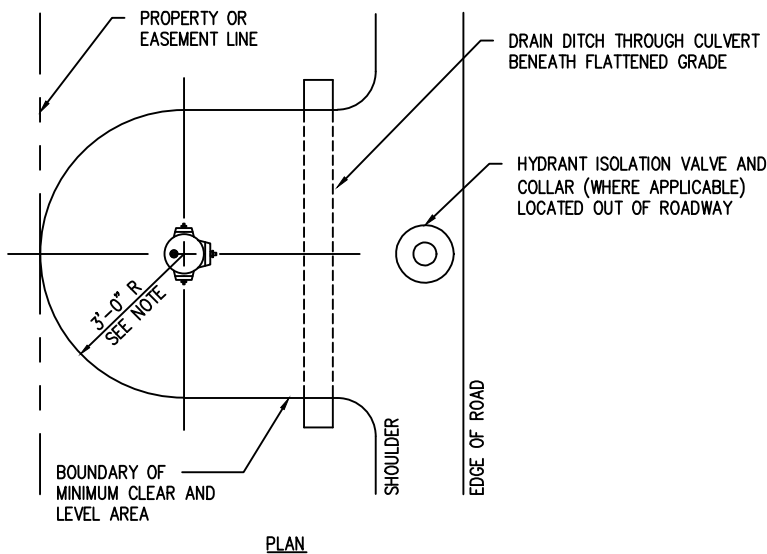

**NOTES:**

1. SURFACE TO 4" THICK CONCRETE PAD, FREE FROM OBSTRUCTIONS, LEVEL, AND UNIFORMLY GRADED AROUND HYDRANT, MIN OF 3 FEET IN ALL DIRECTIONS.
2. ROCKERY OR KEYSTONE TYPE RETAINING WALL TO BE PROVIDED WHERE NECESSARY IN CUT AND FILL AREAS.

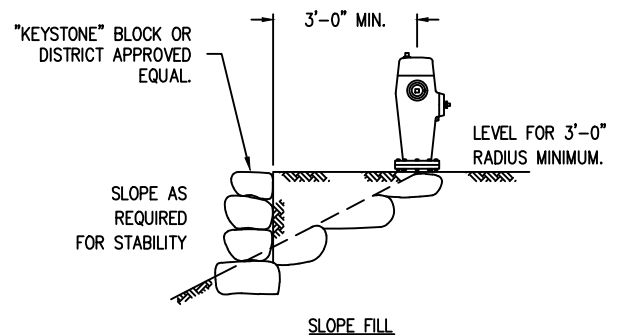
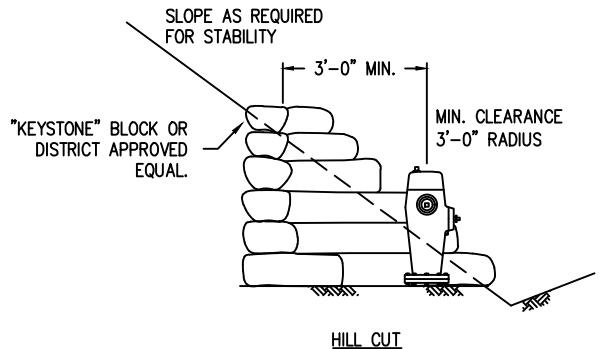

**CLEARANCE AND GRADING REQUIREMENTS FOR HYDRANTS**

**FIRE HYDRANT LOCATIONS**

DRAWING NO.

**412**

| NO. | REVISIONS                     | DATE       | BY  |
|-----|-------------------------------|------------|-----|
| 1   | REARRANGED AND ADDED HEADINGS | 02/18/2020 | HSC |
| 2   |                               |            |     |
| 3   |                               |            |     |
| 4   |                               |            |     |

DATE: 07/07/2017  
 SCALE: NTS

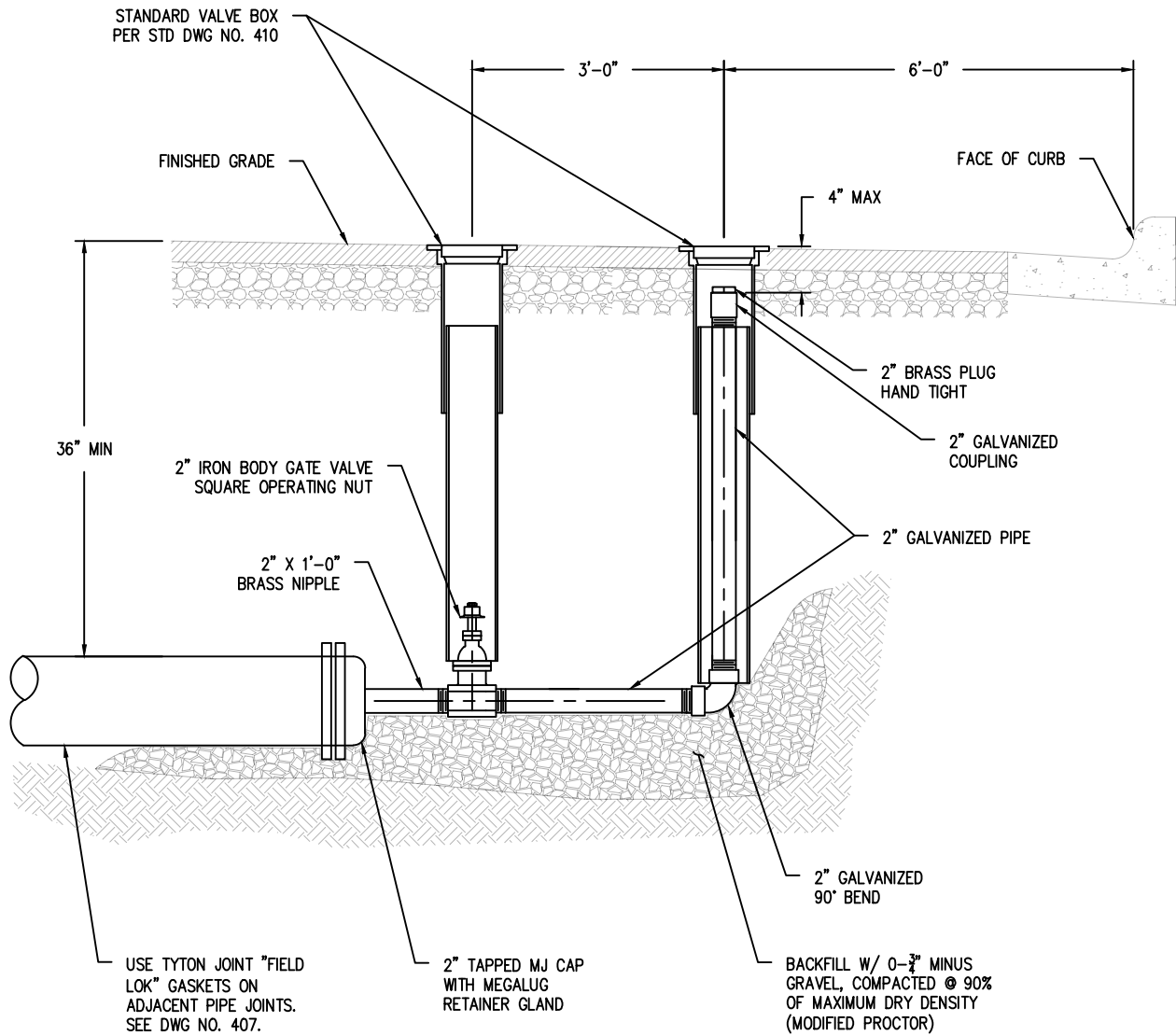

| NO. | REVISIONS | DATE | BY |
|-----|-----------|------|----|
| 1   |           |      |    |
| 2   |           |      |    |
| 3   |           |      |    |
| 4   |           |      |    |

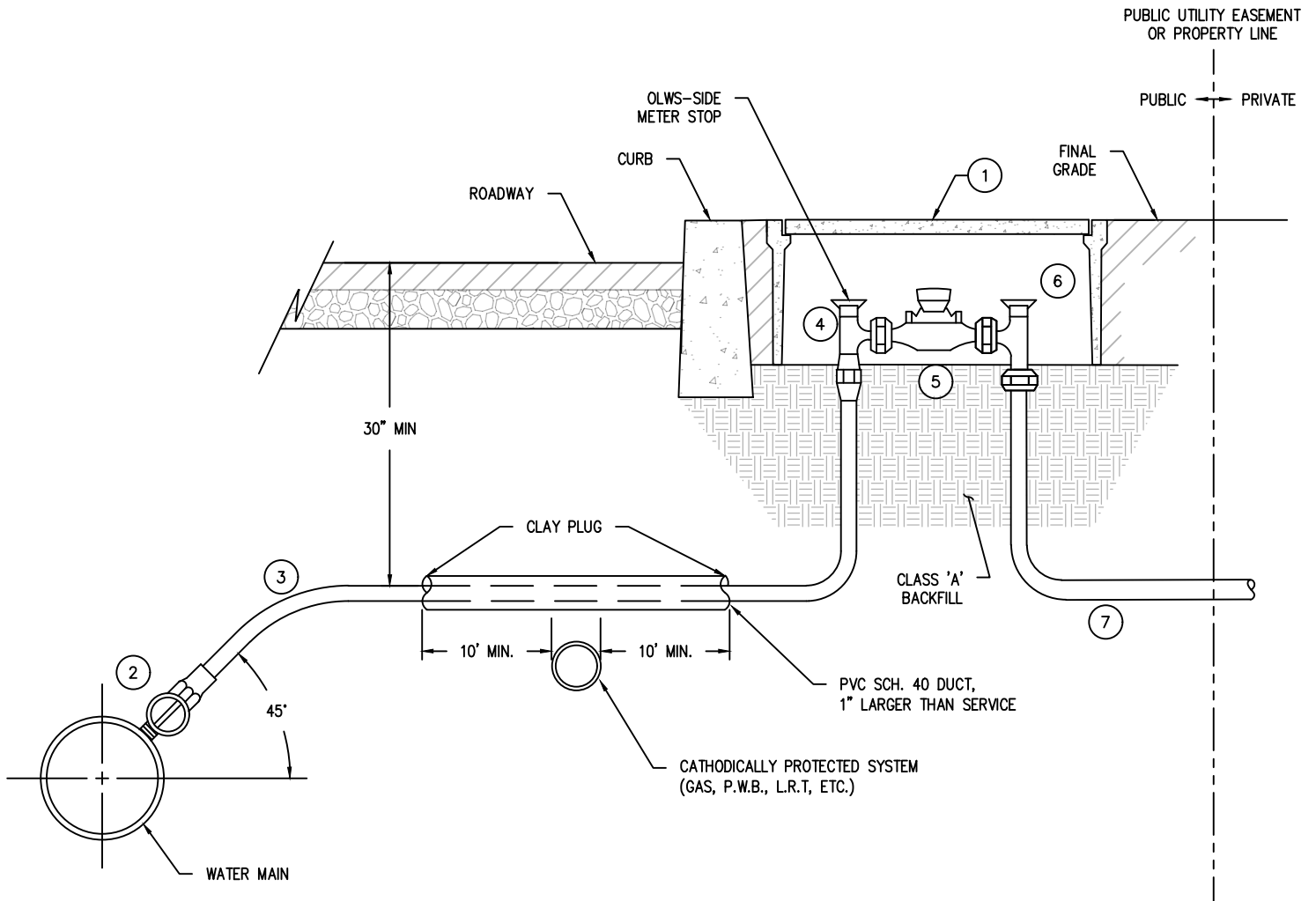

**NOTES:**

1. SUBSTITUTES FOR ANY MATERIALS SHOWN SHALL BE PRE-APPROVED BY OLWS.
2. WATER MAIN TRENCH MUST BE 3-FOOT WIDE X 6-FOOT DEEP MINIMUM, WITH 1-FOOT CLEAR BEHIND THE MAIN AND 1-FOOT CLEAR UNDER THE MAIN.
3. ALL PIPE AND STRUCTURE ZONES SHALL BE BACKFILLED USING 3/4" MINUS CRUSHED AGGREGATE AND COMPACTED TO 95% MAX. DENS. AS DETERMINED BY AASHTO T-180. COPPER SERVICE SHALL BE BEDDED AND COVERED WITH BACKFILL 6" ALL AROUND SERVICE. IN ROADS, BACKFILL SHALL BE EXTENDED TO TOP OF EXCAVATION.
4. WHEN AN ACTIVE CATHODIC PROTECTED SYSTEM IS ENCOUNTERED, SCH. 40 PVC SHALL BE INSTALLED AS SHOWN ABOVE WITH CLAY PLUG.
5. THE COMPLETE WATER SERVICE MUST BE INSPECTED OLWS PRIOR TO BACKFILL OR BE RE-EXCAVATED WITHOUT COST TO OLWS.
6. FOR LOCATION OF OLWS-SIDE METER STOP RELATIVE TO PROPERTY LINE, EASEMENT LINE, CURB, OR SIDEWALK, SEE DRAWING 430.

**KEYNOTES:**

1. OLWS STANDARD METER BOX WITH TOP OF LID AT FINAL GRADE.
2. CORPORATION STOP VALVE. FULL-PORT BALL TYPE UNIT TAPPED DIRECTLY INTO WATER MAIN WITH MALE IRON PIPE THREADS. OPERATING NUT INSTALLED IN 3 O'CLOCK OR 9 O'CLOCK POSITION.
3. 3/4" OR 1" SOFT TEMPER, TYPE 'K' COPPER TUBING COMPLYING WITH ASTM B-88. ENTIRE SERVICE SHALL BE SINGLE PIECE OF NEW PIPE FROM CORP STOP TO OLWS-SIDE METER STOP. COPPER-TO-COPPER UNIONS ARE ONLY ACCEPTABLE WHEN WATER SERVICE IS LONGER THAN 100 FEET AND ONLY WITH PRIOR APPROVAL OF DISTRICT ENGINEER.
4. OLWS-SIDE METER STOP INSTALLED 7" TO 9" BELOW FINISH GRADE. FULL-PORT BALL TYPE ANGLED METER STOP WITH LOCKING WINGS.
5. WATER METER, TO BE SUPPLIED AND INSTALLED BY OLWS.
6. CUSTOMER-SIDE METER STOP SAME AS OLWS-SIDE, EXCEPT BOTH BALL-TYPE AND KEY-TYPE ARE ACCEPTABLE AND LOCKING WINGS ARE NOT REQUIRED.
7. CUSTOMER-SIDE PLUMBING WITHIN THE METER BOX SHALL BE PEX OR COPPER. PVC IS NOT ACCEPTABLE.

| NO. | REVISIONS                             | DATE       | BY  |
|-----|---------------------------------------|------------|-----|
| 1   | SPECS                                 | 02/18/2020 | HSO |
| 2   | TRENCH DIMENSIONS AND UNION ALLOWANCE | 12/14/2020 | HSO |
| 3   | NOTE CORRECTIONS                      | 3/5/2024   | TAP |
| 4   |                                       |            |     |

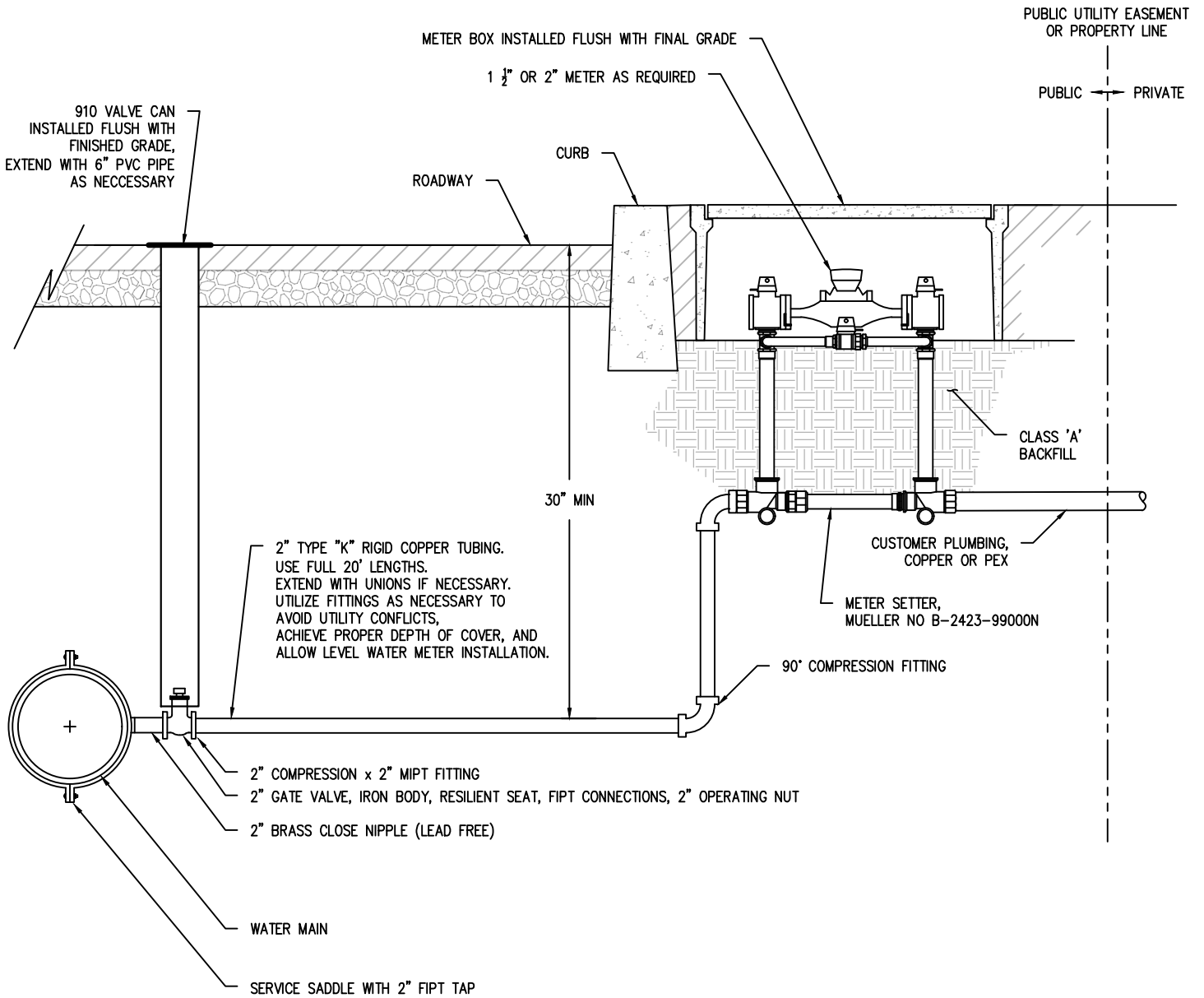

1 1/2" AND 2" WATER SERVICE ASSEMBLY

| NO. | REVISIONS               | DATE       | BY  |
|-----|-------------------------|------------|-----|
| 1   | CLARIFICATION AND TYPOS | 12/14/2020 | HCO |
| 2   | ADDED METER SETTER      | 7/30/2024  | TAP |
| 3   |                         |            |     |
| 4   |                         |            |     |

DRAWING NO.

421

DATE: 02/18/2020

SCALE: NTS

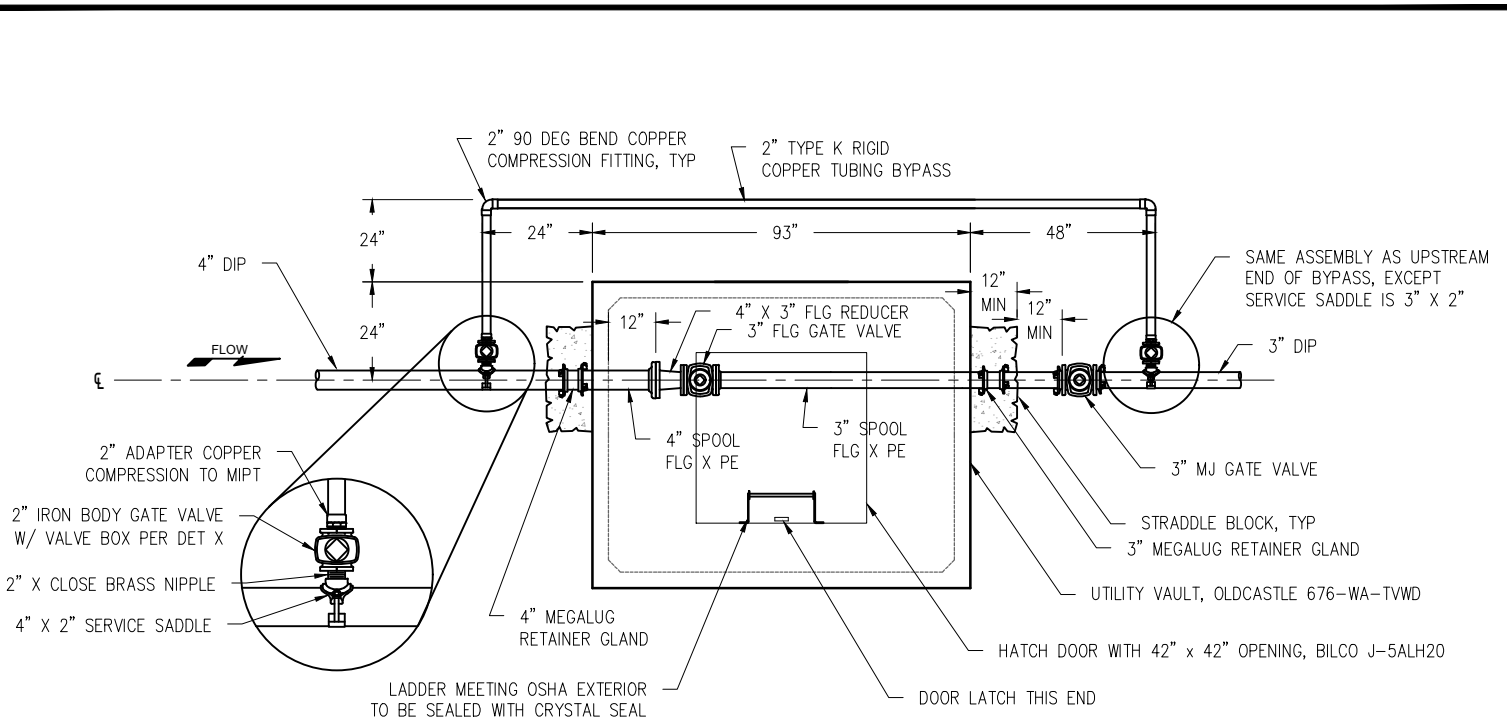

**PLAN**

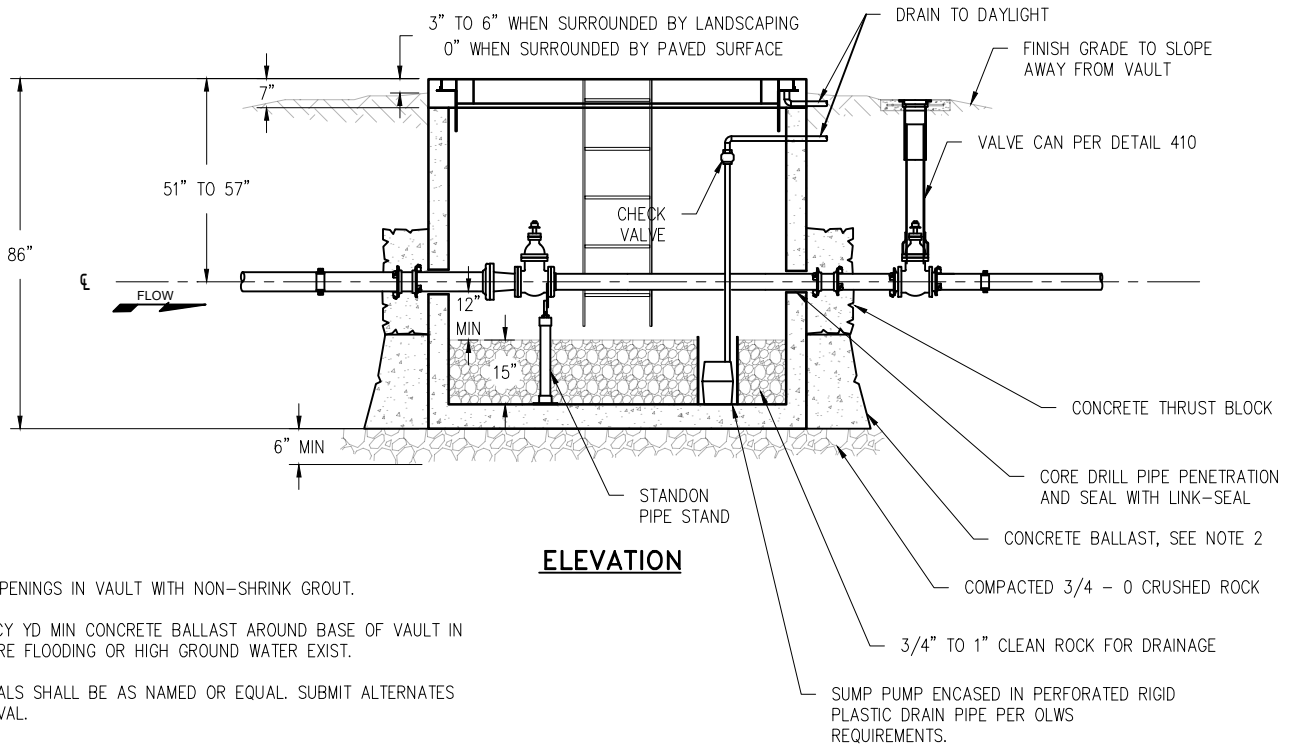

**ELEVATION**

**NOTES:**

1. SEAL ALL OPENINGS IN VAULT WITH NON-SHRINK GROUT.
2. INSTALL 3 CY YD MIN CONCRETE BALLAST AROUND BASE OF VAULT IN AREAS WHERE FLOODING OR HIGH GROUND WATER EXIST.
3. ALL MATERIALS SHALL BE AS NAMED OR EQUAL. SUBMIT ALTERNATES FOR APPROVAL.
4. ORS 92.044(7) PROHIBITS LOCATING ANY UTILITY INFRASTRUCTURE WITHIN 12 INCHES OF A SURVEY MONUMENT. DEVELOPER SHALL PAY FOR ANY RELOCATION OF SERVICES AND/OR METER BOXES FOUND TO FALL WITHIN 12 INCHES OF A SURVEY MONUMENT LOCATION.

| NO. | REVISIONS | DATE | BY |
|-----|-----------|------|----|
| 1   |           |      |    |
| 2   |           |      |    |
| 3   |           |      |    |
| 4   |           |      |    |

1st PREFERENCE – METER BOX LOCATED IN PLANTER STRIP

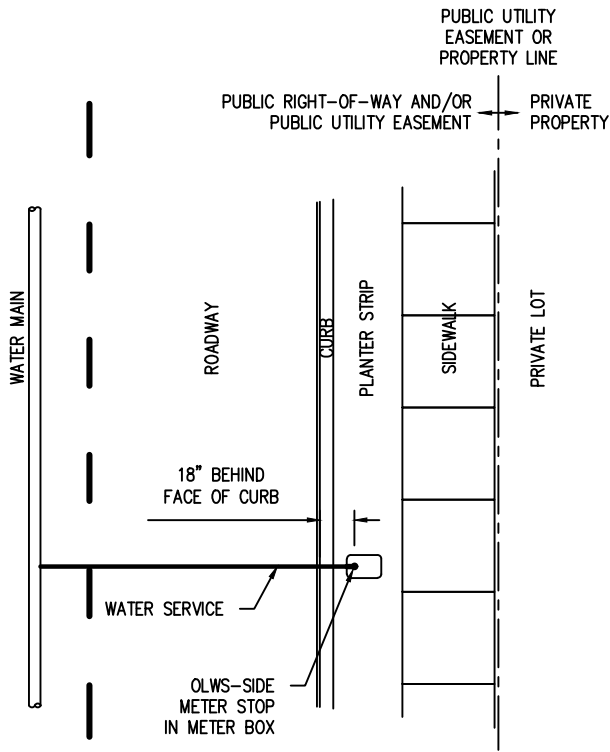

2nd PREFERENCE – METER BOX LOCATED BEHIND SIDEWALK

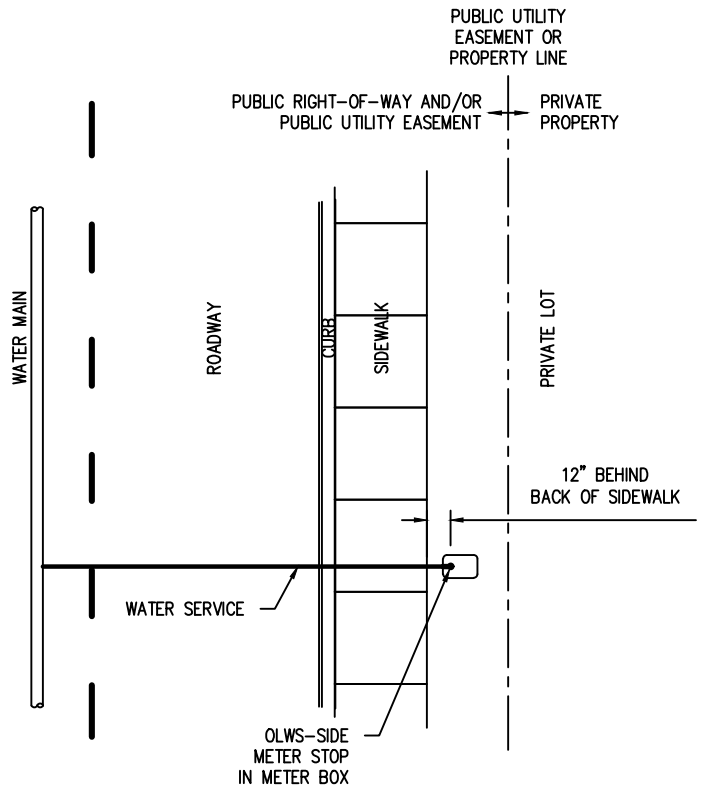

3rd PREFERENCE – METER BOX LOCATED IN SIDEWALK

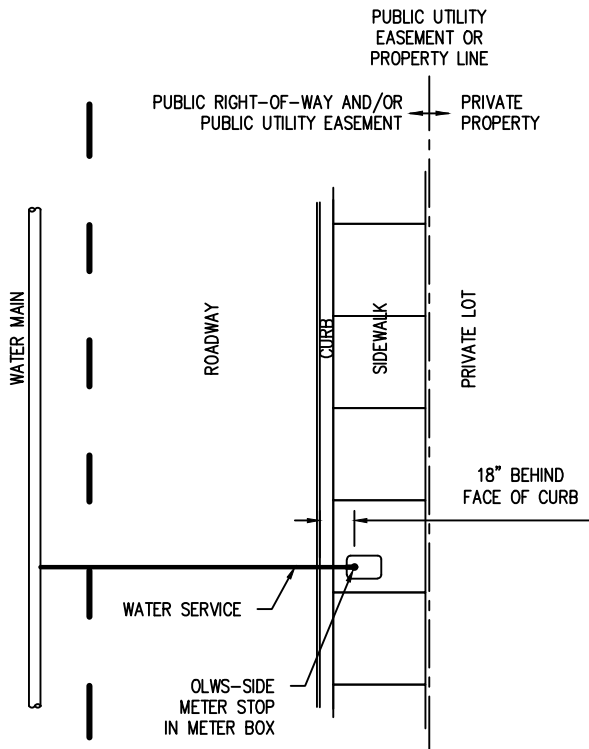

4th PREFERENCE – NEITHER CURB NOR SIDEWALK PRESENT

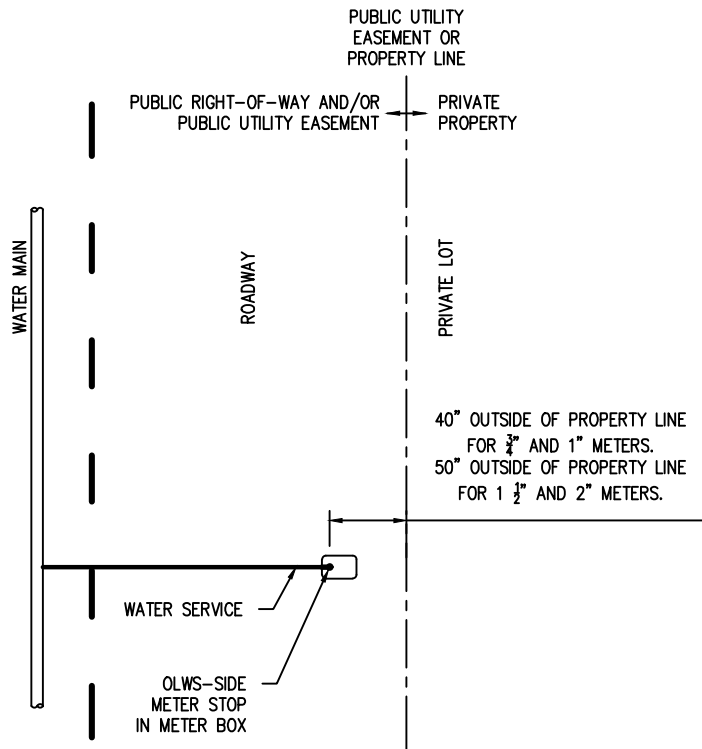

| NO. | REVISIONS      | DATE       | BY  |
|-----|----------------|------------|-----|
| 1   | EVERYTHING     | 02/18/2020 | HSD |
| 2   | DRAWING NUMBER | 12/14/2020 | HSD |
| 3   |                |            |     |
| 4   |                |            |     |

PUBLIC UTILITY EASEMENT  
OR PROPERTY LINE

PRIVATE ← PUBLIC

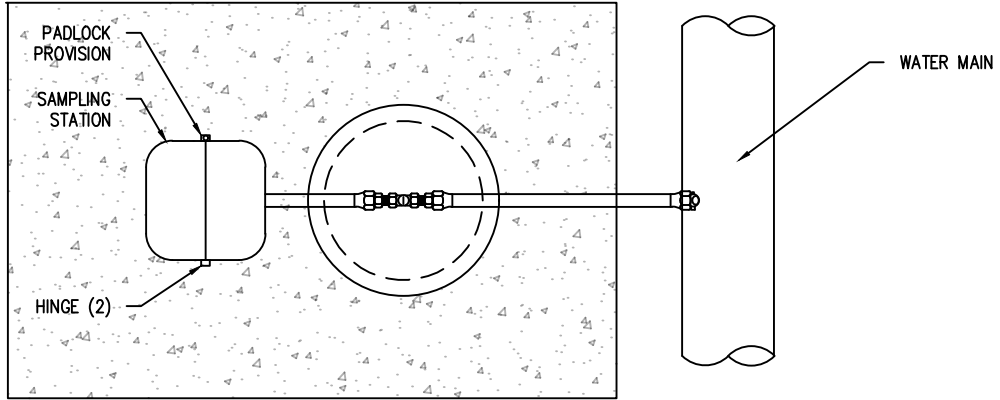

KUPFERLE ECLIPSE NO 88-SS SAMPLING  
STATION WITH STAINLESS STEEL  
STANDPIPE, NON THREADED STAINLESS  
STEEL SAMPLING BIB (EXTERIOR) AND 1/2"  
VALVE ON DRAIN LINE. DOOR OPENING  
PERPENDICULAR TO STREET OR SIDEWALK.

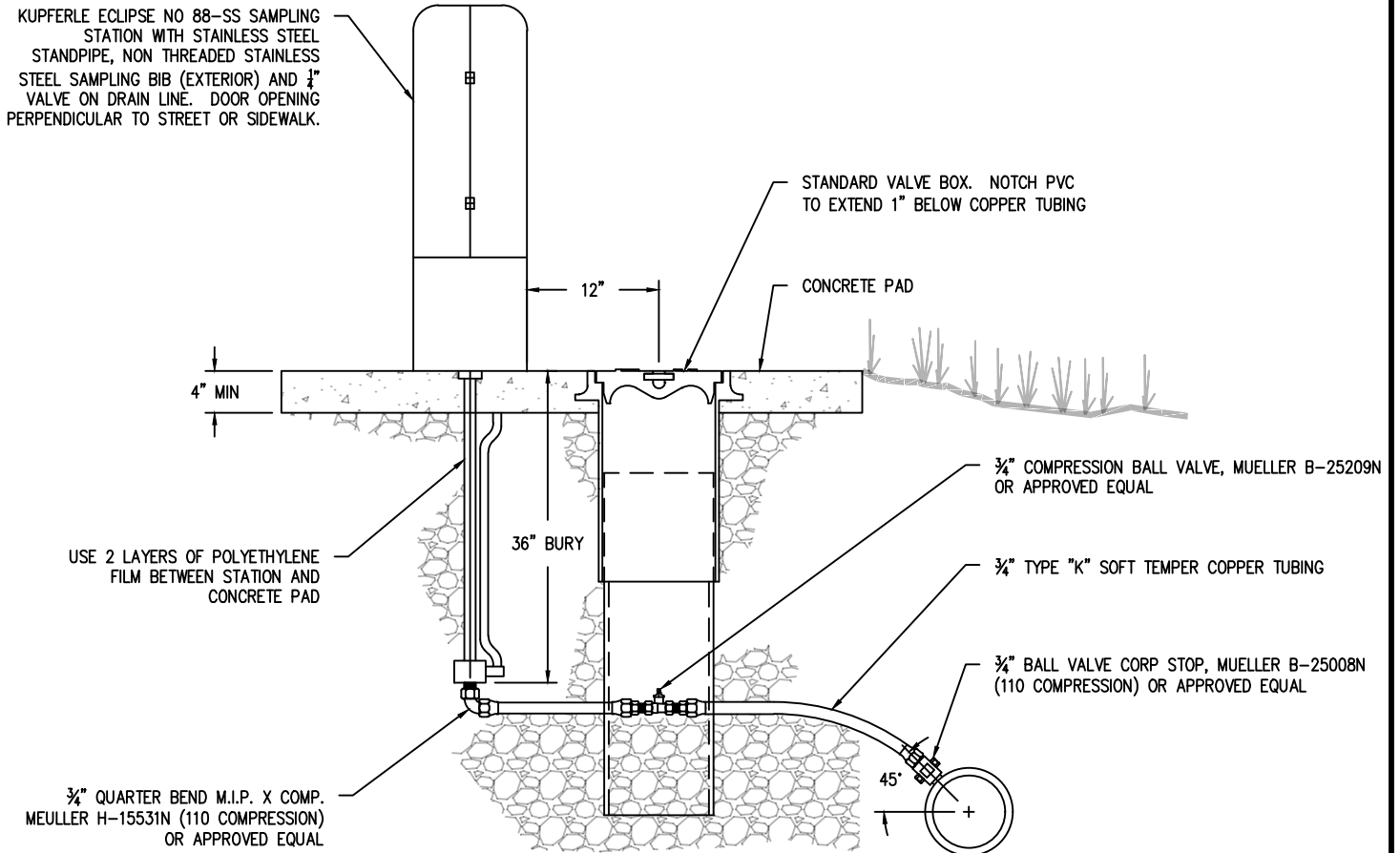

NOTES:

1. PIPE ZONE MATERIAL SHALL BE 3/4"-0" CRUSHED ROCK GRANULAR BACKFILL COMPACTED TO 95% OF AASHTO T-99.
2. WHEN CROSSING CATHODICALLY PROTECTED SYSTEM, INSTALL PVC SLEEVE
3. WHERE NO SIDEWALK EXISTS, PLACE CONCRETE PAD AS SHOWN. WHERE SIDEWALK EXISTS, PLACE MIN. 12" AROUND BACK OF SAMPLE STATION AND INCORPORATE INTO NEW CONCRETE POUR.
4. COLOR: STOCK GREEN

**OAK LODGE**  
WATER SERVICES

WATER SYSTEM STANDARD DRAWING

WATER SAMPLING STATION

| NO. | REVISIONS | DATE | BY |
|-----|-----------|------|----|
| 1   |           |      |    |
| 2   |           |      |    |
| 3   |           |      |    |
| 4   |           |      |    |

DRAWING NO.

435

DATE: 7/30/2024

SCALE: NTS